



PACKMAN
Industrial Group

Last update: 10/12/2022

Mechanical Modular and Mechanical Staging Gas or Dual-Fuel Burner

From 300 kW up to 6200 kW

www.packmangroup.com
www.raadmanburner.com

- raadman -
A look to the future



More than
48 Years of Reliability

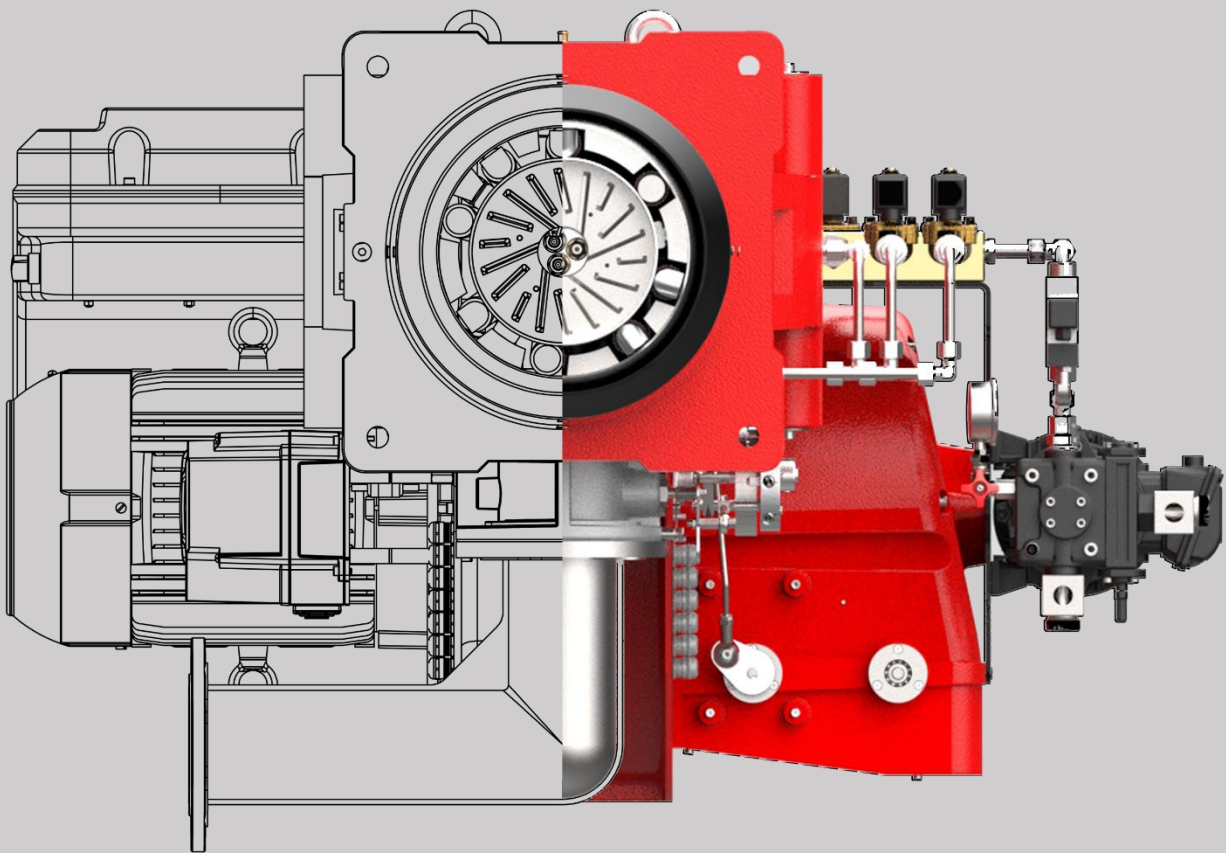

History

The PACKMAN Company was established in February of 1975. This company started its official activity in the field of construction of High-Pressure Vessels such as Hot-Water Boilers, Steam Boilers, Pool Coil Tanks, Softeners and Heat Exchangers from 1984. As the first supplier of Hot water boilers with high quality and standard mark, PACKMAN has started exporting its products to countries such as Uzbekistan, United Arab Emirates and other countries in the region. Currently, PACKMAN honor-fully is one of the largest producers of hot-water and steam boilers in the Middle East. After 40 years of experience in the field of heating industry, especially boilers and burners, this group started its activity in January 2011 in the area of burners with the brand of raadman. The main objective of this group was improvement and development of industrial burners in order to produce high quality and highly efficient industrial burners with optimum operation in the Middle East. Based on technical knowledge and engineering design of industrial burners, PACKMAN Corporation started the production of low, medium and big sized industrial burners. By the efforts of engineers of the R & D department, the burner's combustion improved significantly and as a consequence, the production of burners developed rapidly. Gas, Light oil (LFO), Heavy oil (HFO) and dual/triple fuel burners with different firing ranges were produced and tested successfully.

Nowadays, the burners of this company cover a firing range of 100 to 60000 kW. Single stage, double stage, modular and Low NOx burners (generally lower than 80 mg/kWh and individually lower than 40 mg/kWh) are available for various domestic and industrial applications. High quality, optimum operation and customer satisfaction has always been considered in the production of raadman burners. Diversity and high quality of raadman burners, besides their easy installation and maintenance make them a perfect selection for many customers.



R LG B- MC - 255 / LN

Blank: NOx class: II acc to BS-EN-676

LN: Low NOx with Class III acc to BS-EN-676

Reference of approximate Capacity x 10 kW

Operation:

Blank:	Two Stage or One Stage
M:	Natural Gas, LPG: Electronic Modular Light Oil, Heavy Oil: Two/Three Stage Progressive
MC:	Natural Gas, LPG: Mechanical Modular Light Oil, Heavy Oil: Two/Three Stage Progressive
MS:	Natural Gas, LPG: Mechanical staging Light Oil, Heavy Oil: Two/Three Stage Progressive
M/M:	Natural Gas, LPG: Electronic Modular Light Oil, Heavy Oil: Electronic Modular

B: Burner

Type of Fuel:

G:	G= Natural Gas
GP:	G= Natural Gas, P= Propane
LG:	L= Light oil, G= Natural Gas
LGP:	L= Light oil, G= Natural Gas, P= Propane
LHG:	L= Light oil, H= Heavy oil, G= Natural Gas
LHGP:	L= Light oil, H= Heavy oil, G= Natural Gas, P= Propane

Product Family Name: RAADMAN

Note: Due to the same firing rate, working diagram and gas train, the MC series and MS series are brought into the same section, where the MC series represent MC series and MS series both.

Firing rate

RGB-MC Series

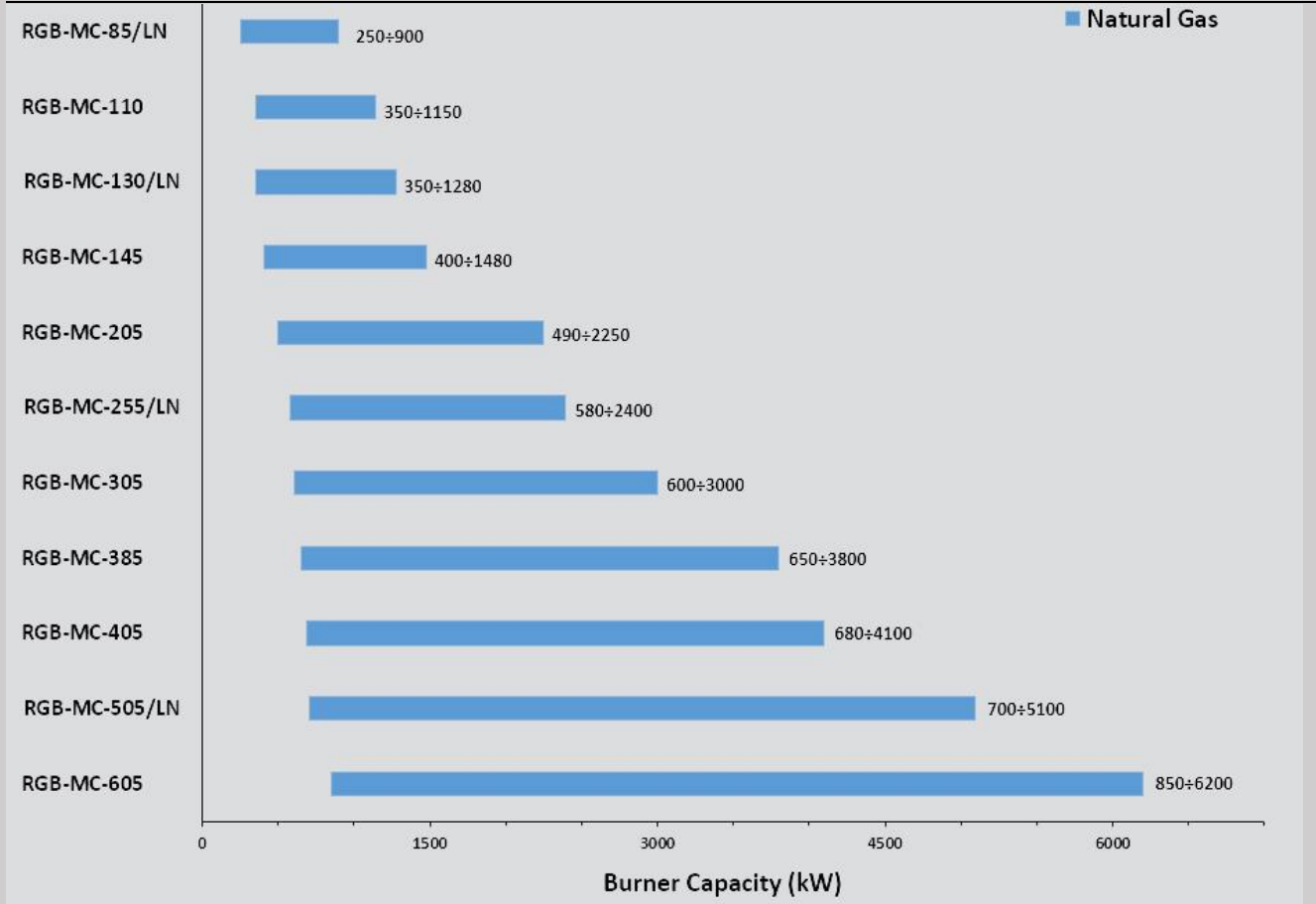

RLGB-MC Series

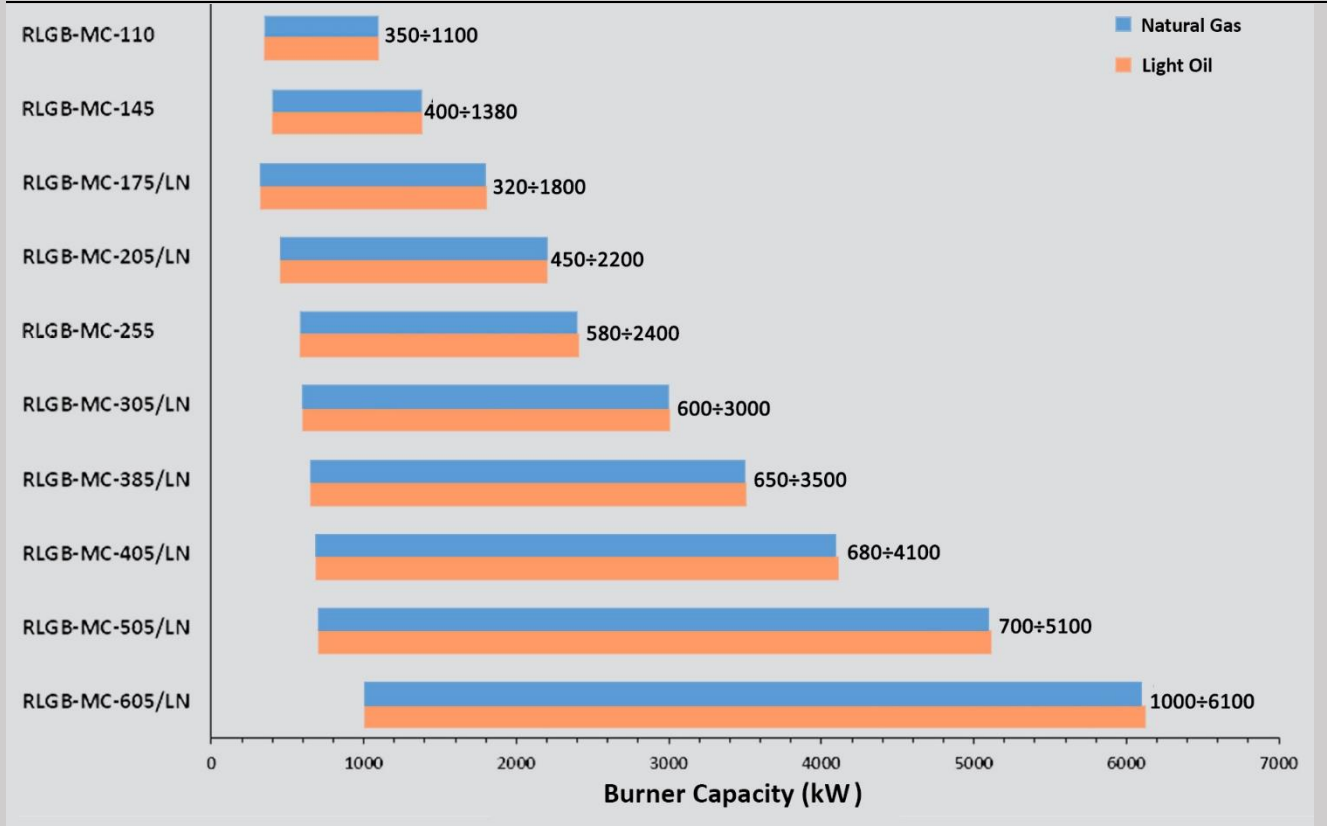

Mechanical modular radman burners

RGB-MC series of burners cover a firing range from 1000 to 6000 kW, and they are manufactured with high-quality electro/mechanical accessories with easy installation and commissioning. They are mechanically resistant and are economically designed for city or industrial applications such as three pass hot water boilers, steam boilers, hot air generators, etc.

Their operation is “two-stage” at the oil side and “modulating” at the gas side with the installation of a PID logic regulator and respective probes. The customers should kindly note that the PID regulator is not included in the burners routine process and should be ordered separately.

RGB-MC series burners guarantee high-efficiency levels in all the various applications, thus reducing fuel consumption and running costs. Optimization of sound emissions is guaranteed by the special design of the air suction circuit and the use of soundproofing material. The exclusive design ensures reduced dimensions, simple use, and maintenance. A wide range of accessories guarantees elevated working flexibility

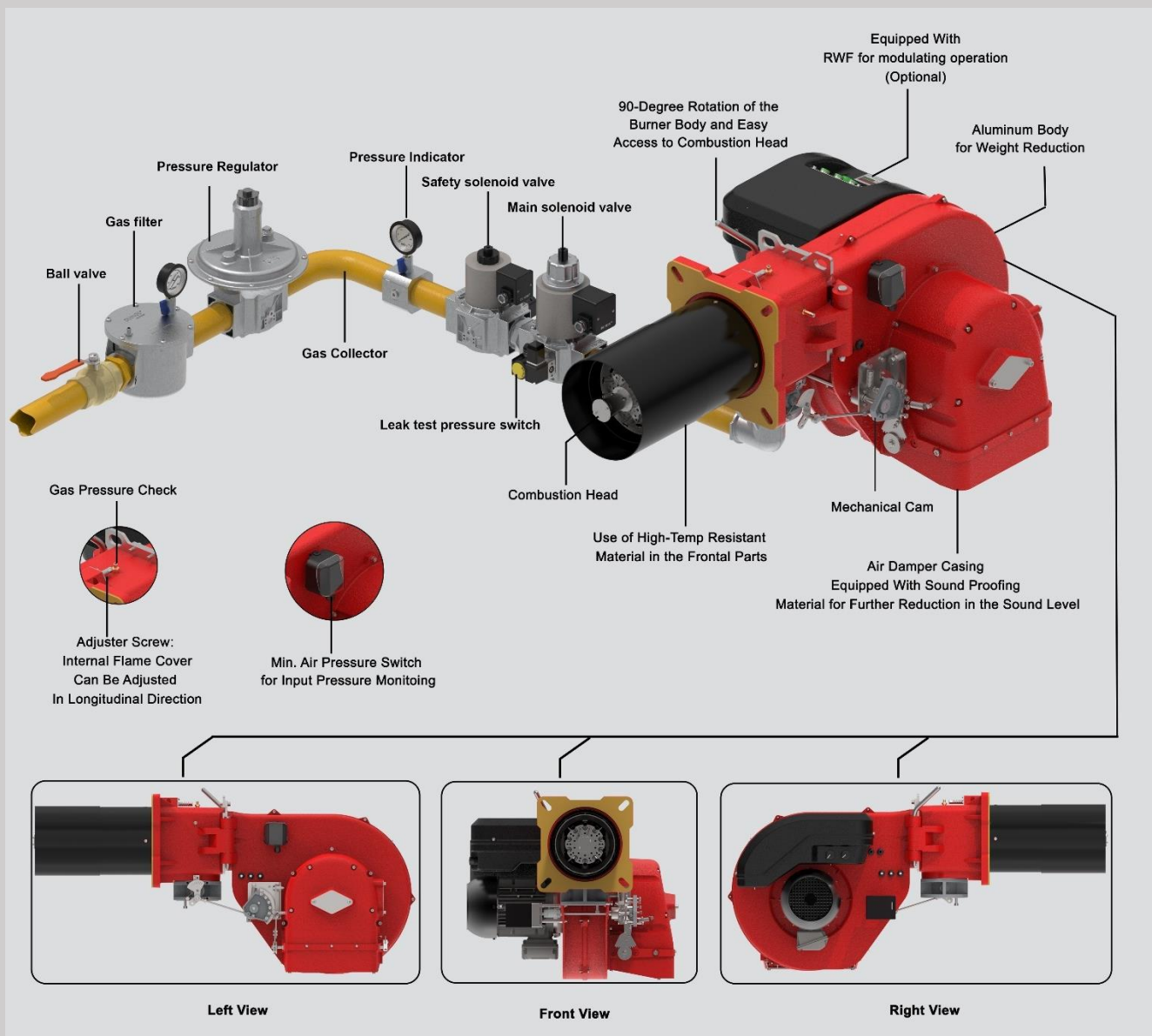

CFD experts in R&D department

The industry relies on heat from the burners in all combustion systems. Optimizing burner performance is critical to comply with stringent emissions requirements and to improve industrial productivity. Engineers involved in designing and building advanced combustion equipment for the hydrocarbon process industries routinely use Advanced CFD to advance new burner technology. The science and technology of CFD have matured to the point where performance predictions are made with a degree of confidence from models covering a wide range of complex furnace, burner, and reactor geometries.

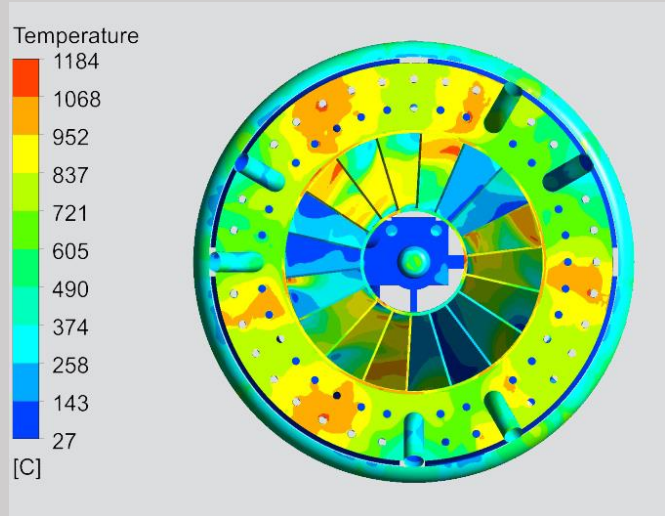

While tremendous advances have been made in understanding the fundamentals of combustion, the remaining challenges are complex. To make improvements, it is critical to understand the dynamics of the fuel fluid flow and the flame and its characteristics. Computational Fluid Dynamics offers a numerical modeling methodology that helps in this regard. Commercial CFD codes utilize a standard approach to simulate chemical kinetics, which approximates the consumption and production of chemical species. This causes the engineer to use simplifying assumptions about the chemistry considered in the simulation. CFD can help engineers to optimize flow through orifices, blades, and swirlers to achieve a homogenous mixture of air and gas.

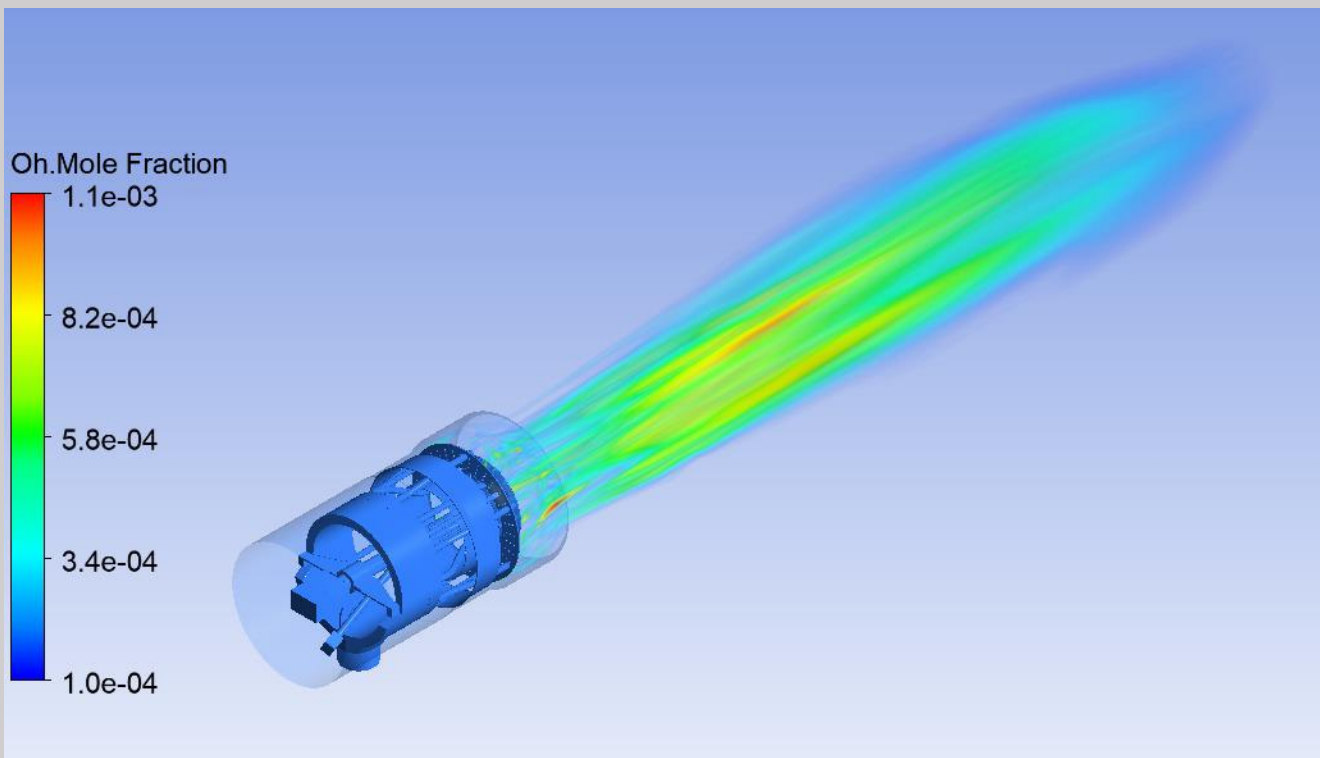

Specification



Fuels

- Natural gas
- Light oil (viscosity < 6 sCt)
- Other types of fuels (such as heavy oil, LPG, etc.) requires written confirmation from burner department of packman corporation (raadman brand).

Applications

raadman gas and dual fuel burners are suitable for the following utilization.

- Installation on heat exchanger
- Hot water boiler
- Steam boiler and high-pressure hot water boiler
- Hot air generator
- Compatible with all types of combustion chambers according to EN303 standard.

Control

The following methods of regulation are available for RGB-MC and RLGB-MC Series burners:

Oil: Two-stage operation

Gas: Two-stage progressive or modulating operation, with a specific kit (PID regulator and related temperature or pressure sensors).

Technical & Functional Features

- Lightweight and optimized geometry.
- High-quality heat-resistant steel material for all parts of burner head as well as flame covering accessories.
- Air damper for air flow setting and butterfly valve for regulating gas output controlled by a servomotor with variable cam
- Mono-bloc design and fully enclosed aluminum air housing.
- Simple installation, adjustment, and maintenance.
- Easy access to internal components.
- Engineered to maximize efficiency and fuel cost savings.
- Suitable for firetube, firebox, and watertube boilers
- Equipped with high-quality and reliable electronic devices.
- Up to 10-20 % flame shape control
- High-quality staging controllers from well-known producers.

Standard compliance

- Designed in accordance with ISIRI-7595 and ISIRI-7594 Iran national standards (equal to the BS-EN676, BS-EN267 European standards)

Permissible ambient conditions:

- Ambient temperature
- -10 to +40 °C (14 to 104F)
- -15 to +40 °C (5 to 104F)

Air humidity: max. 80 % relative humidity, no condensation.

The combustion air must be free of aggressive substances (halogens, chlorides, etc.) and impurities (dust, debris, vapors, etc.)

Emission:

The emissions have been measured in various models at the maximum output, according to DIN-EN 676 and DIN-EN 297 standards.

The values of CO and NOx during burner operation are lower than 30 and 120 mg/kWh at 20 % excess of air for normal versions and, lower than 20 and 80 mg/kWh for Low NOx versions (LN series). consequently, the burner's NOx class of II and III is reported and being approved for normal version and LN Versions respectively.

Special notes:

LN versions have a higher rate of mixing during their operation. This results in a further decrease in the flame length and an increase in the flame diameter.

Burner management system overview

Mechanical modular management system

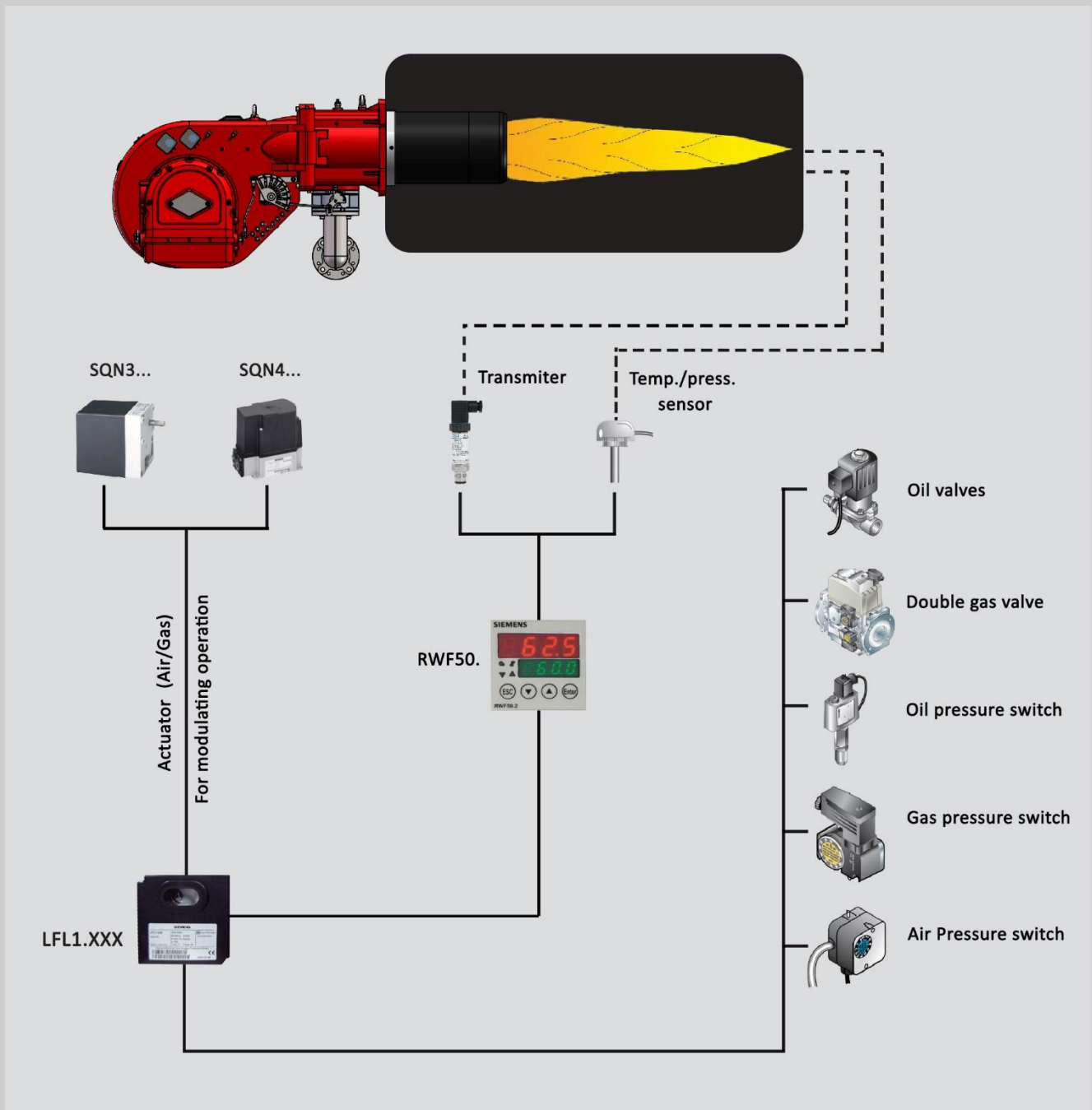

To obtain modulating operation, the RGB-MC series of burners requires a regulator with three-point outlet controls. The following lists the accessories are required for the mechanical modulating operation.

- RWF50
- Temperature sensor
- Actuator modulating operation

Mechanical staging management system

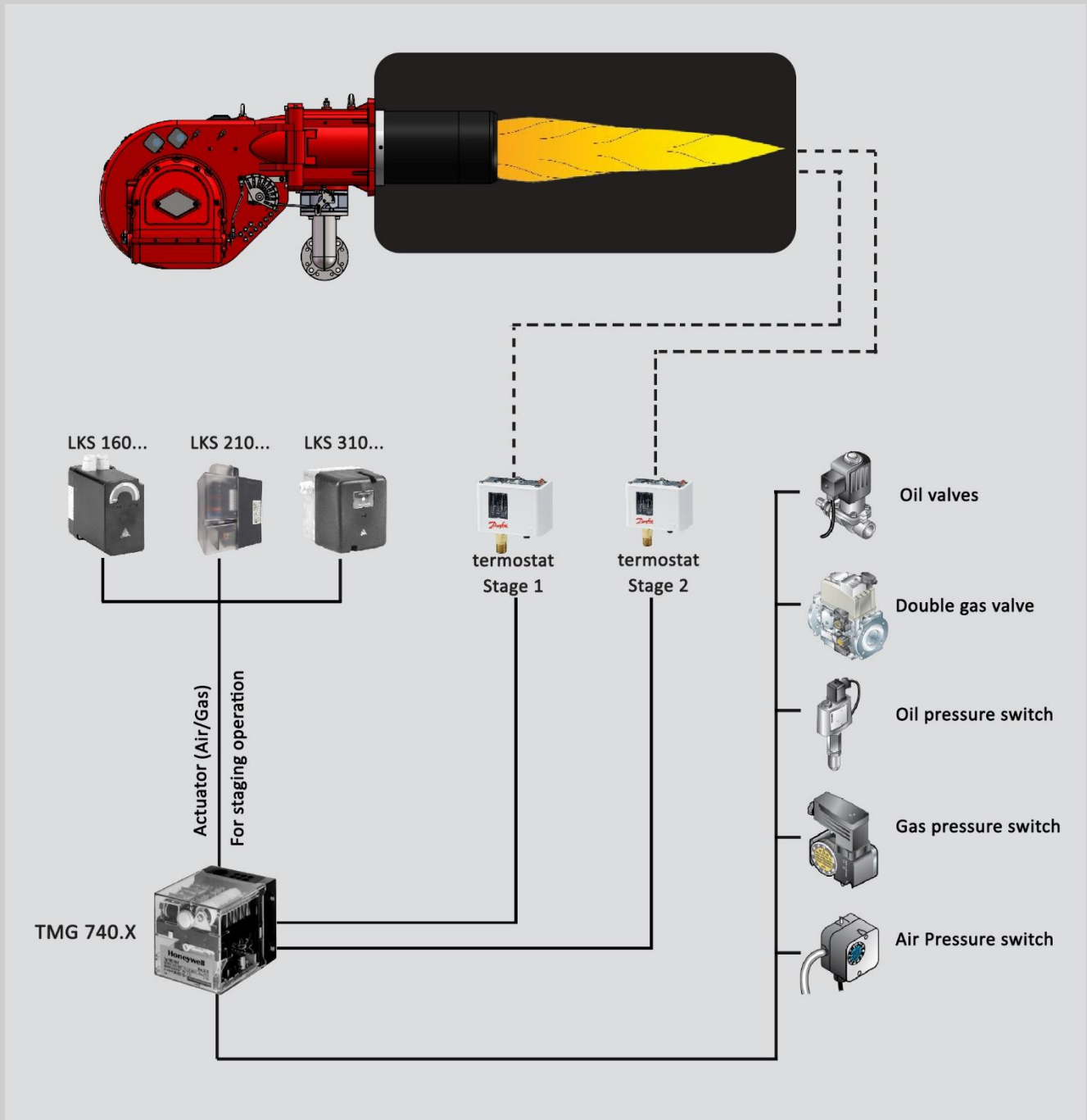

To obtain staging operation, the RGB-MS series of burners requires two thermostat and actuator with 2-stage.

Flame dimension

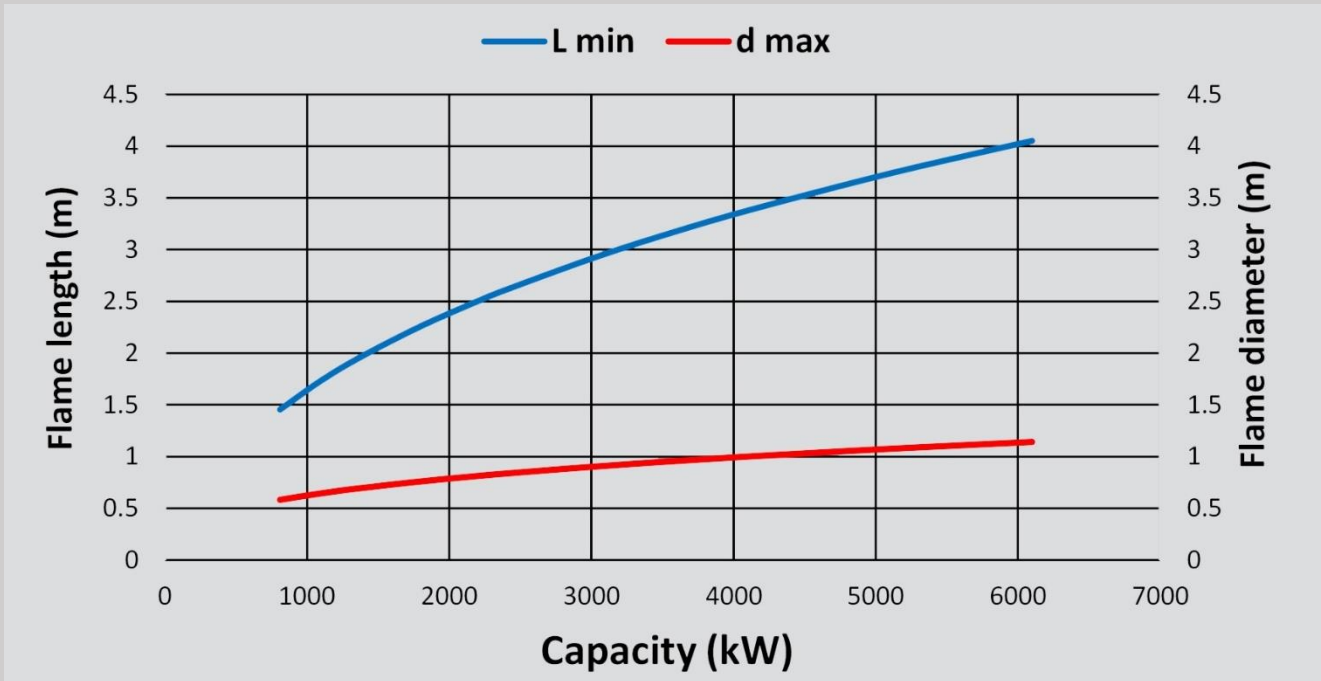

The flame dimensions which play an effective role in the burner efficiency and influence their compatibility to the boiler combustion chamber geometry, are presented in the above diagram.

SUGGESTED COMBUSTION CHAMBER DIMENSIONS:

The radman burners can be appropriately selected for all boilers which are designed according to the BS-2790, BS-855, EN-303, BS-EN 12953-3. It is recommended that a flame fill 90% of combustion chambers at its maximum output.

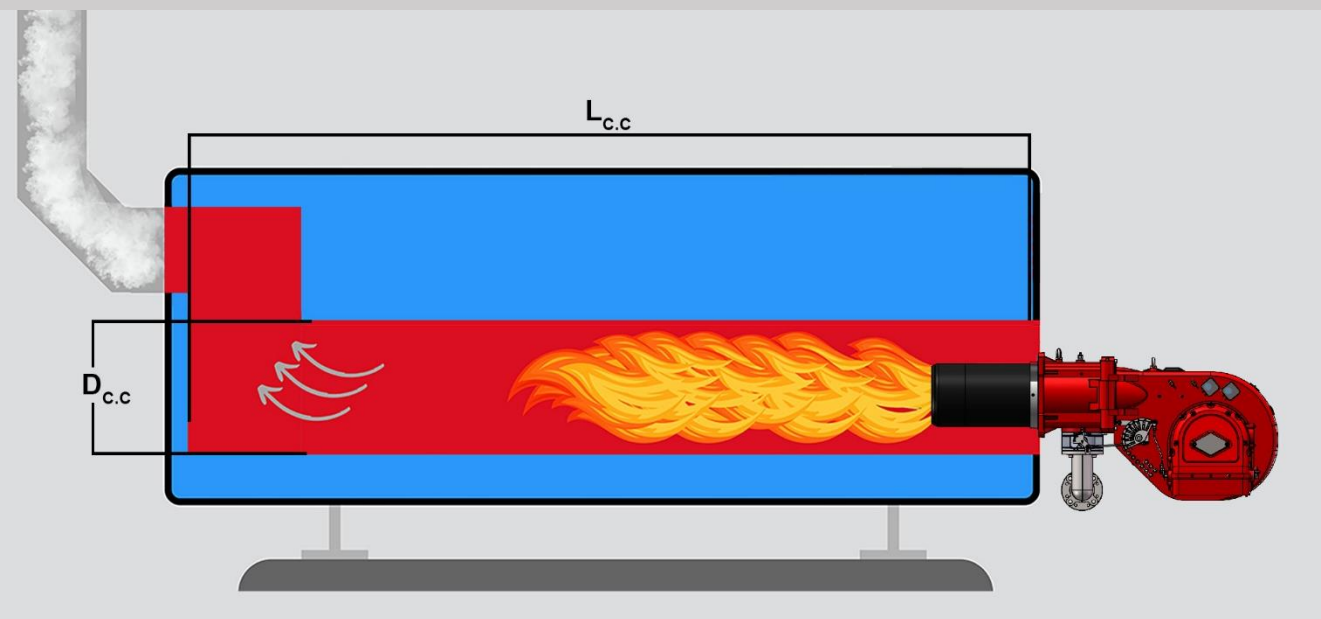
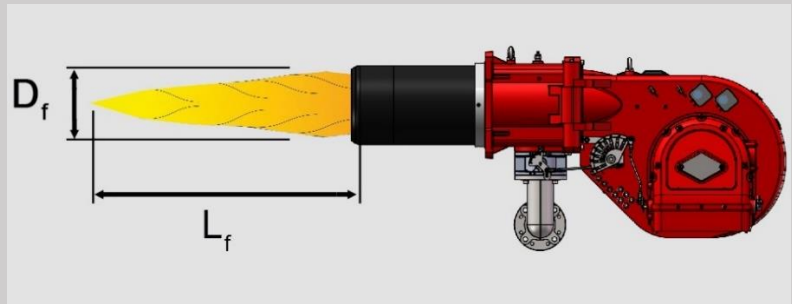

RGB-MC series raadman burner:

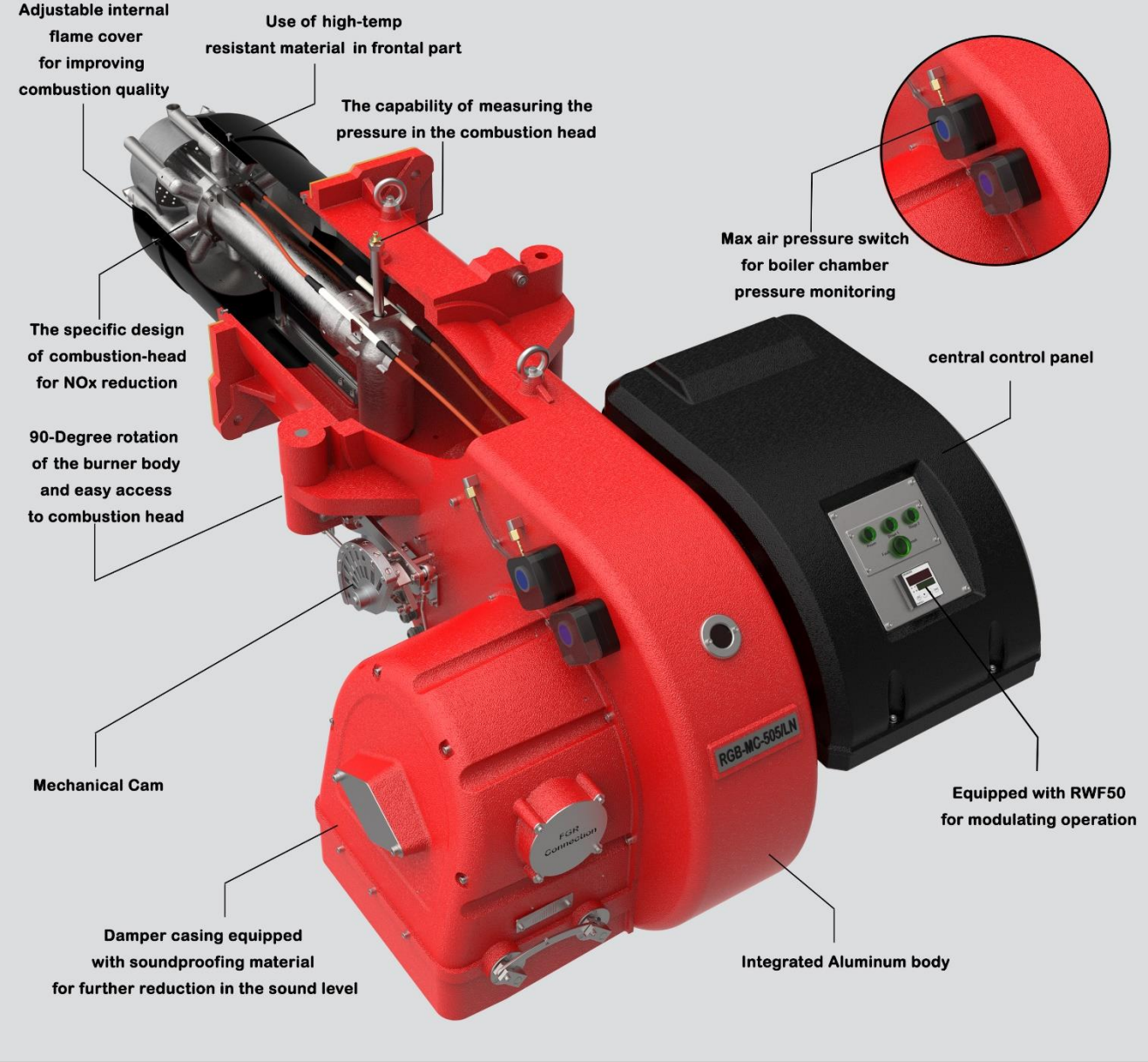

Burner selection: capacity and working diagram

Gas Burner

Burner	Capacity (kW)	Turn Down
RGB-MC-85/LN	NG:250-900	1:3
RGB-MC-130/LN	NG:350-1280	1:3

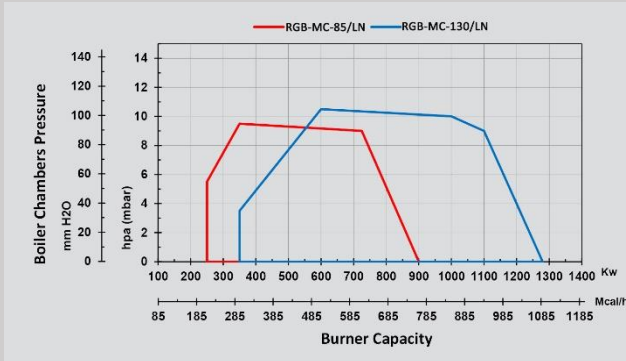

Burner	Capacity (kW)	Turn Down
RGB-MC-110	NG:350-1150	1:3
RGB-MC-145	NG:400-1480	1:4

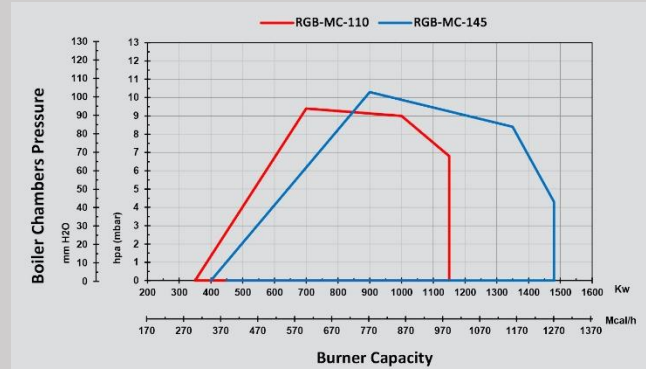

Burner	Capacity (kW)	Turn Down
RGB-MC-205	NG: 490-2250	1:4



Burner	Capacity (kW)	Turn Down
RGB-MC-255/LN	NG:580-2400	1:4

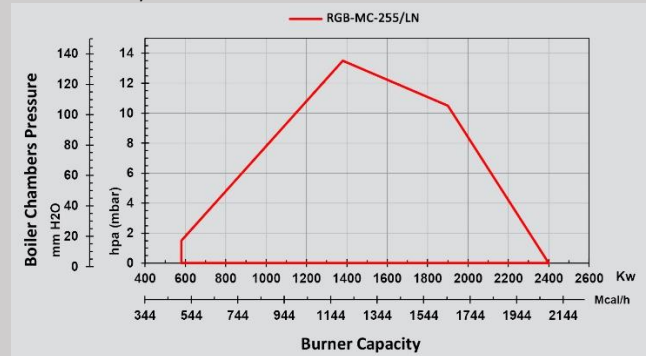

Burner	Capacity (kW)	Turn Down
RGB-MC-305	NG: 600-3000	1:5
RGB-MC-385	NG: 650-3800	1:5

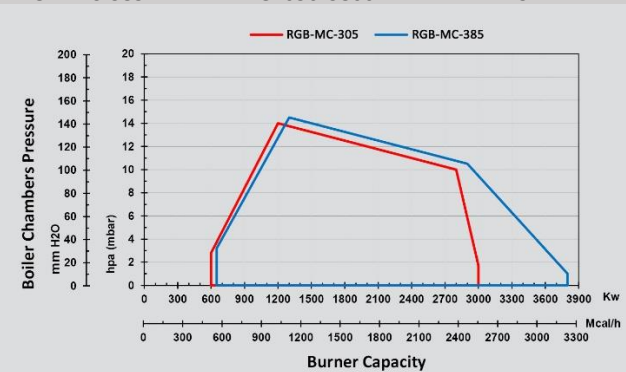

Burner	Capacity (kW)	Turn Down
RGB-MC-405/LN	NG: 680-4100	1:6
RGB-MC-505/LN	NG: 700-5100	1:7

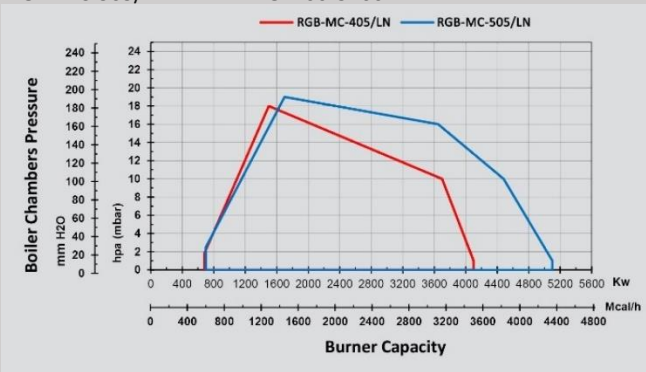

Burner	Capacity (kW)	Turn Down
RGB-MC-605	NG: 850-6200	1:7

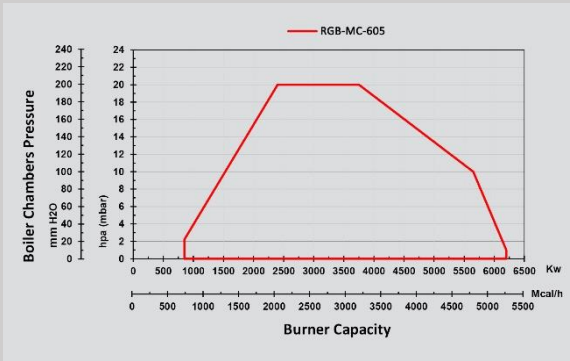

About working diagram

Working diagram for gas burner certified in accordance with BS EN 676.

The firing rate diagram has been obtained considering ambient temperature of 20°C and atmospheric pressure of 1013 mbar (Sea level condition). For installation at higher altitudes, a reduction in capacity of 1% per 100 m above sea level should be taken into account.

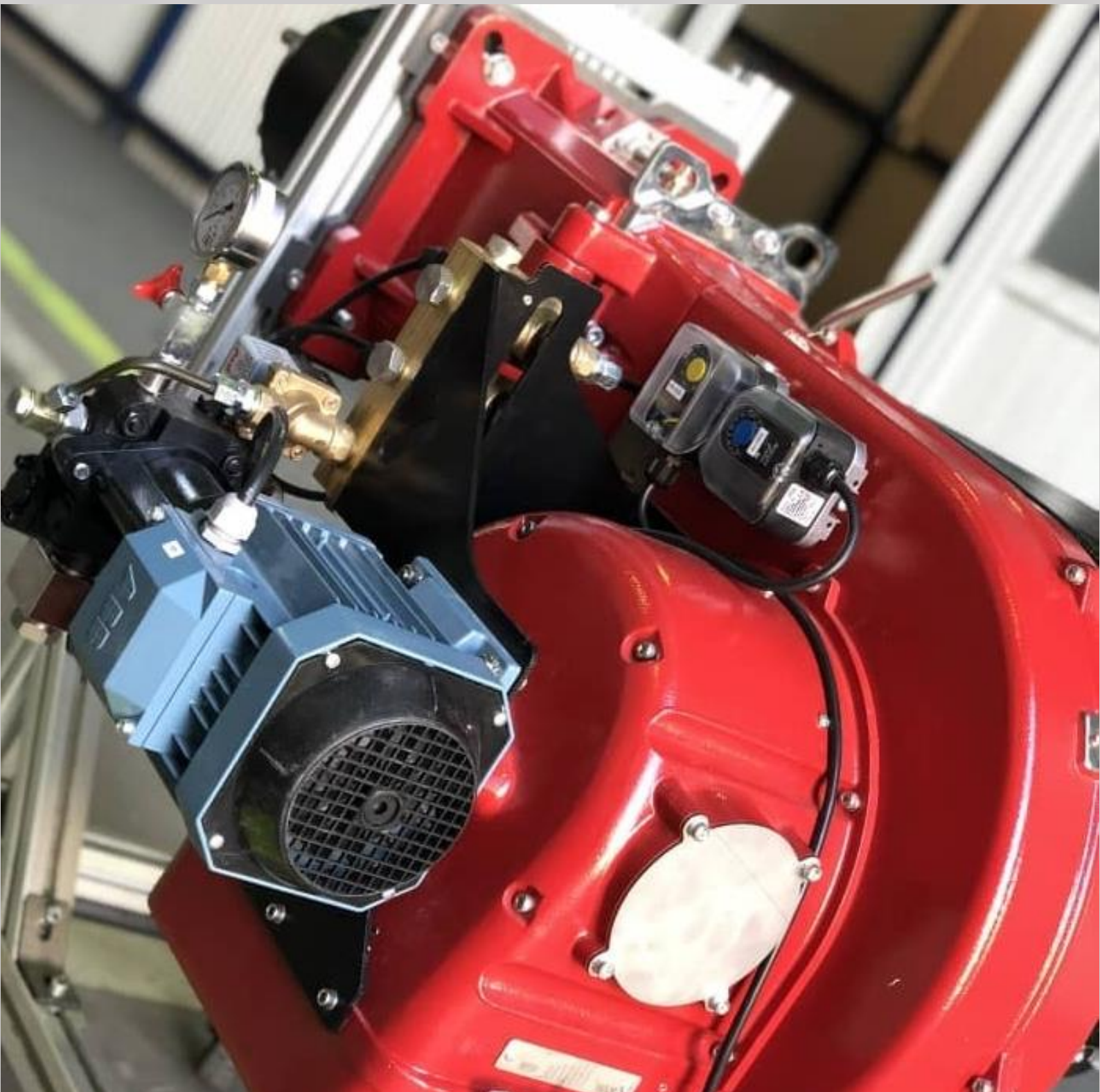

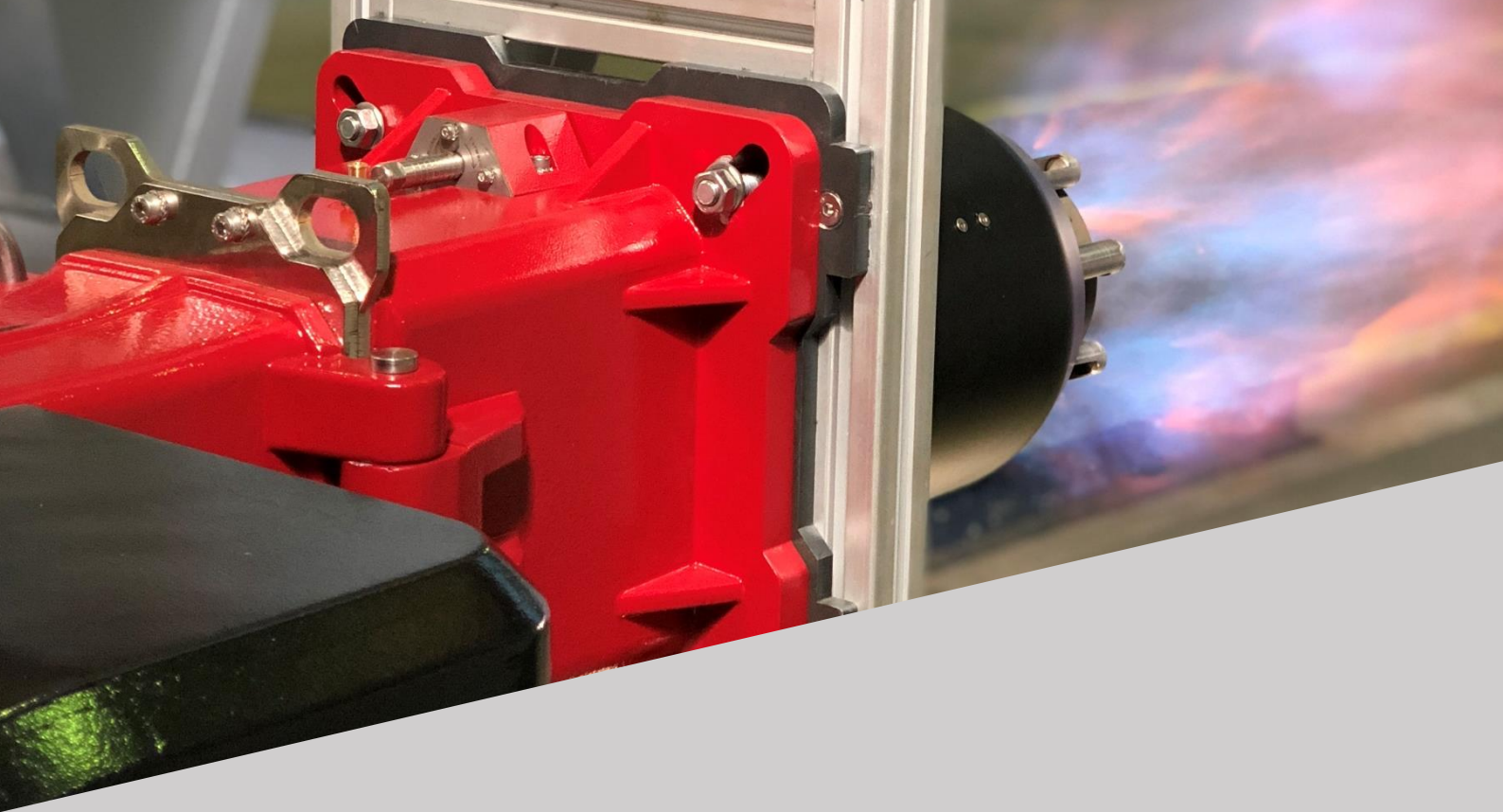

Technical data: RGB-MC series (Gas burner)

RGB-MC Series burner include Ventilation system with AC motor, Ignition transformer, and electrodes, electrical panel with power contactors, fuses, relays, central controller, air pressure switches, soundproofing material, Lamp signals for operational supervision, etc.

- N.G operation: II or III Stages or Mechanical Modular

Burner	Power system		Power management system	
	Motor(kW/PH/V/HZ/rpm)		Controller	Actuator (N.M)
RGB-MC-85/LN	1.5 /3 /380-400 /50 /2840		Siemens/Honeywell	3/2.5
RGB-MC-110	1.5 /3 /380-400 /50 /2840		Siemens/Honeywell	3/2.5
RGB-MC-130/LN	2.2 /3 /380-400 /50 /2840		Siemens/Honeywell	3/2.5
RGB-MC-145	2.2 /3 /380-400 /50 /2840		Siemens/Honeywell	3/2.5
RGB-MC-205	4 /3 /380-400 /50 /2840		Siemens/Honeywell	3/3
RGB-MC-255/LN	5.5 /3 /380-400 /50 /2840		Siemens/Honeywell	3/3
RGB-MC-305	7.5 /3 /380-400 /50 /2900		Siemens/Honeywell	3/3
RGB-MC-385	7.5 /3 /380-400 /50 /2900		Siemens	10
RGB-MC-405/LN	9.2 /3 /380-400 /50 /2900		Siemens	10
RGB-MC-505/LN	11 /3 /380-400 /50 /2900		Siemens	10
RGB-MC-605	15 /3 /380-400 /50 /2900		Siemens	10

General Dimension of RGB-MC series

RGB-MC-85/LN, RGB-MC-130/LN

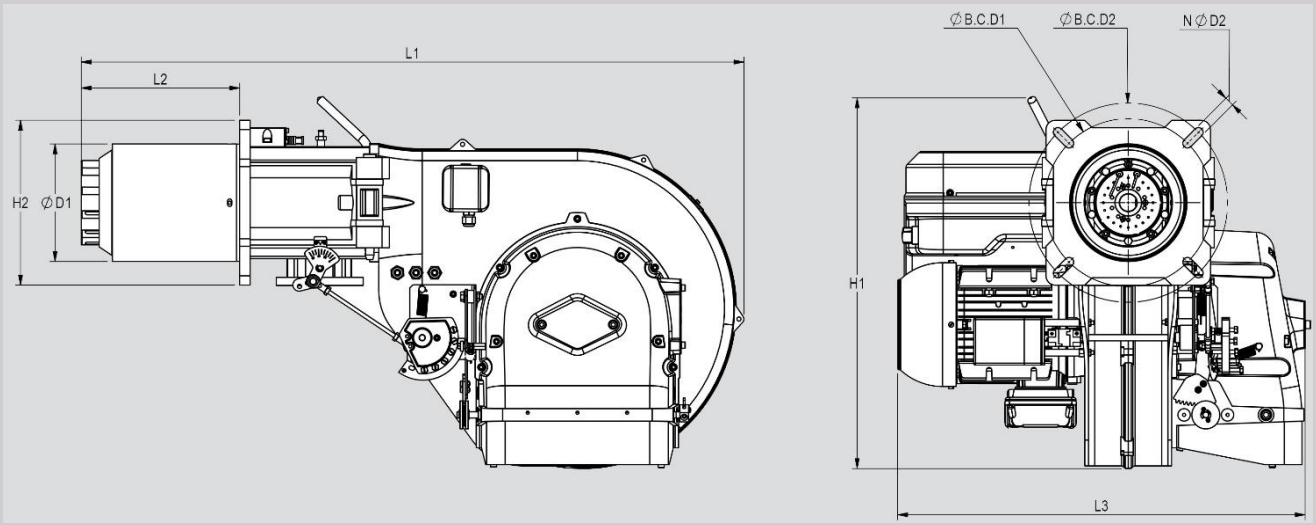

Burner Type	L ₁	L ₂	L ₃	H ₁	H ₂	D ₁	D ₂	N	B.C.D.1	B.C.D.2
RGB-MC-85/LN	1068	255	641	598	265	193	15	4	270	320
RGB-MC-130/LN	1072	260	586	598	265	193	15	4	270	320

RGB-MC-110, RGB-MC-145

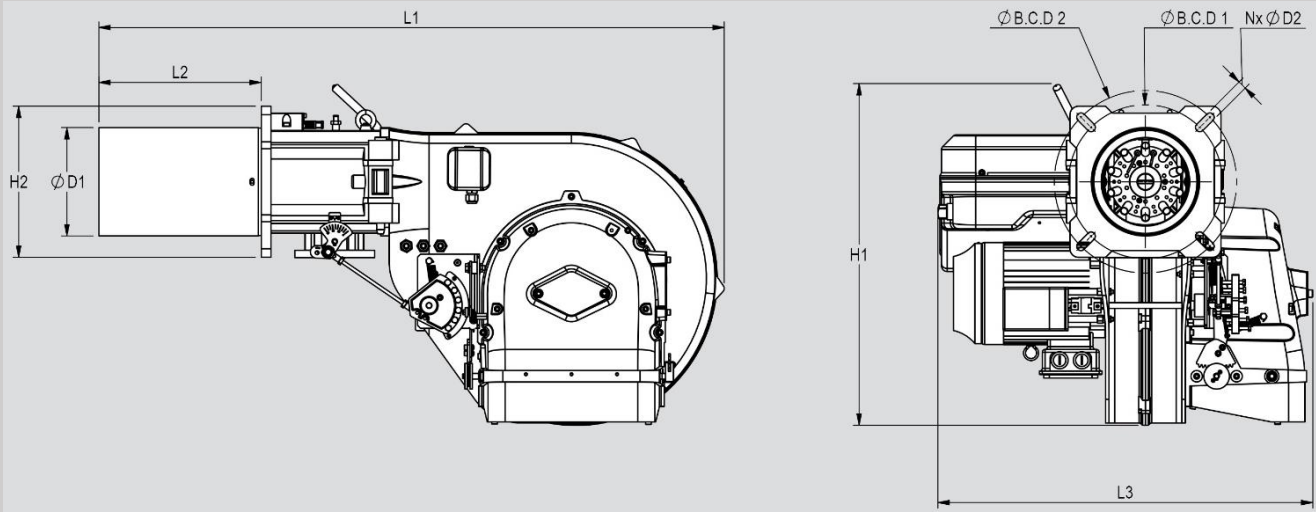

Burner Type	L ₁	L ₂	L ₃	H ₁	H ₂	D ₁	D ₂	N	B.C.D.1	B.C.D.2
RGB-MC-110	1066	254	643	598	265	184	15	4	270	320
RGB-MC-145	1097	285	643	598	265	194	15	4	270	320

RGB-MC-205

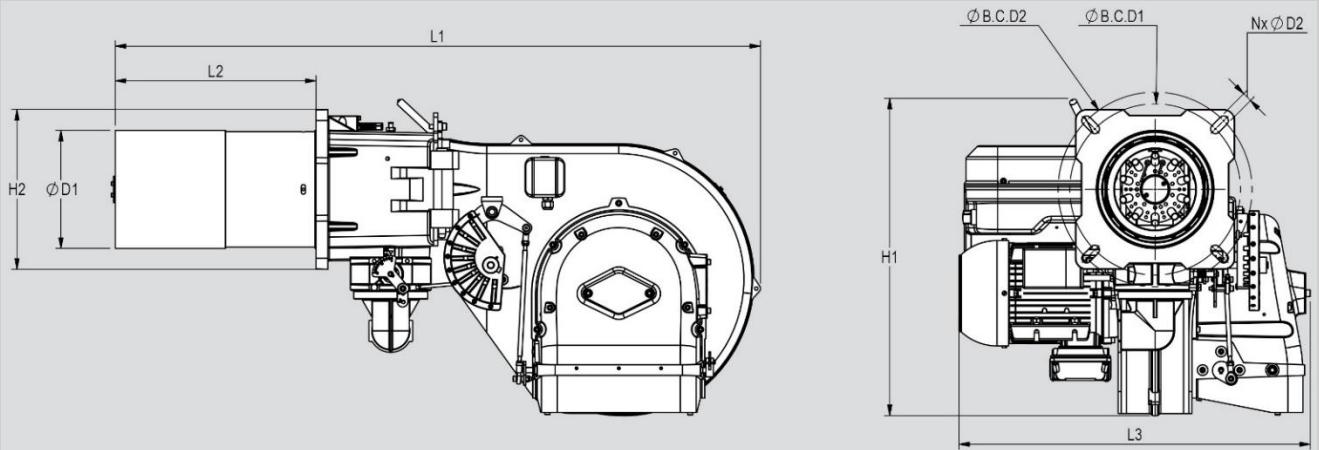

Burner Type	L ₁	L ₂	L ₃	H ₁	H ₂	D ₁	D ₂	N	B.C.D.1	B.C.D.1
RGB-MC-205	1229	388	666	600	302	223	18	4	323	367

RGB-MC-255/LN

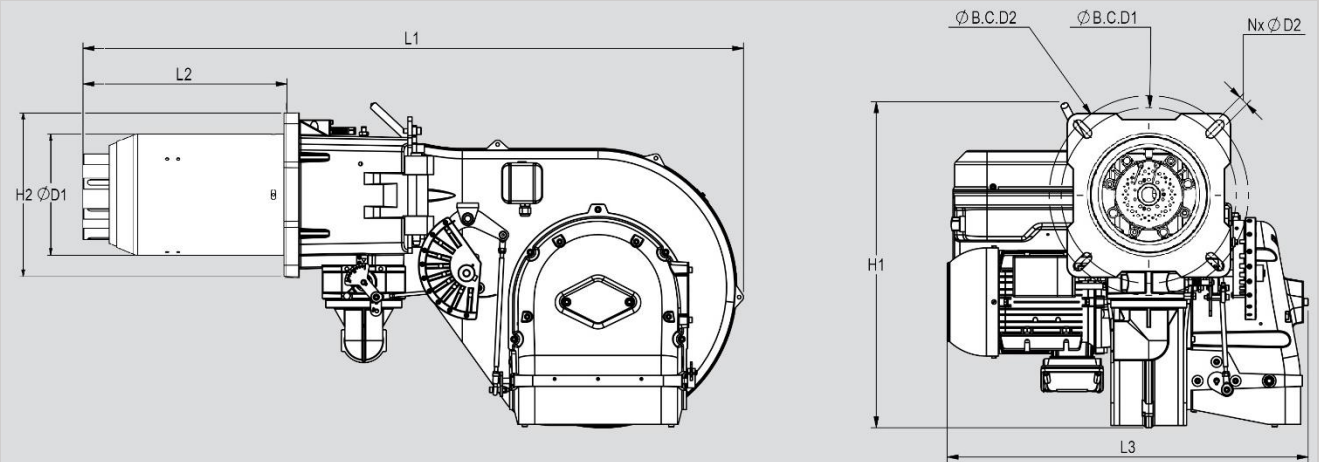

Burner Type	L ₁	L ₂	L ₃	H ₁	H ₂	D ₁	D ₂	N	B.C.D.1	B.C.D.2
RGB-MC-255/LN	1214	374	762	598	300	226	18	4	323	368

RGB-MC-305, RGB-MC-385

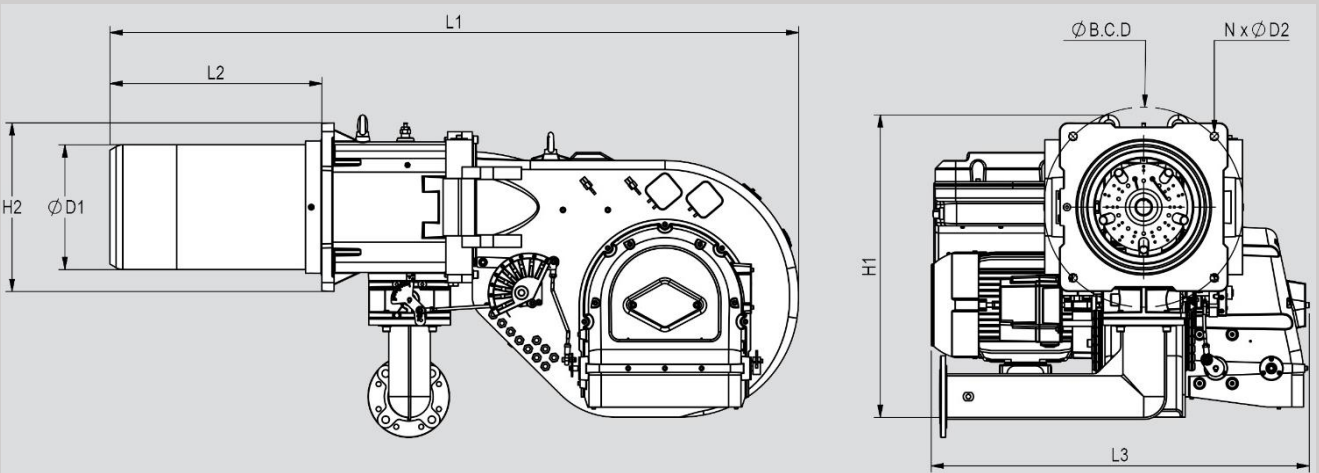

Burner Type	L ₁	L ₂	L ₃	H ₁	H ₂	D ₁	D ₂	N	B.C. D
RGB-MC-305	1689	519.5	927	741	413	328	20	4	490
RGB-MC-385	1689	519.5	927	741	413	328	20	4	490

RGB-MC-405/LN, RGB-MC-505/LN

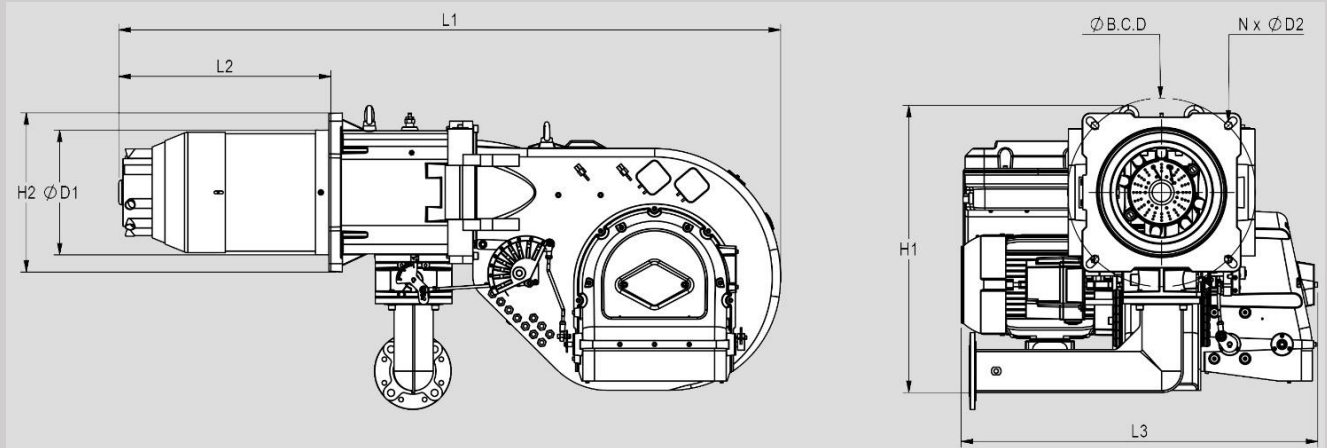

Burner Type	L ₁	L ₂	L ₃	H ₁	H ₂	D ₁	D ₂	N	B.C. D
RGB-MC-405/LN	1721	552	930	798	413	328	20	4	490
RGB-MC-505/LN	1721	552	930	798	413	328	20	4	490

RGB-MC-605

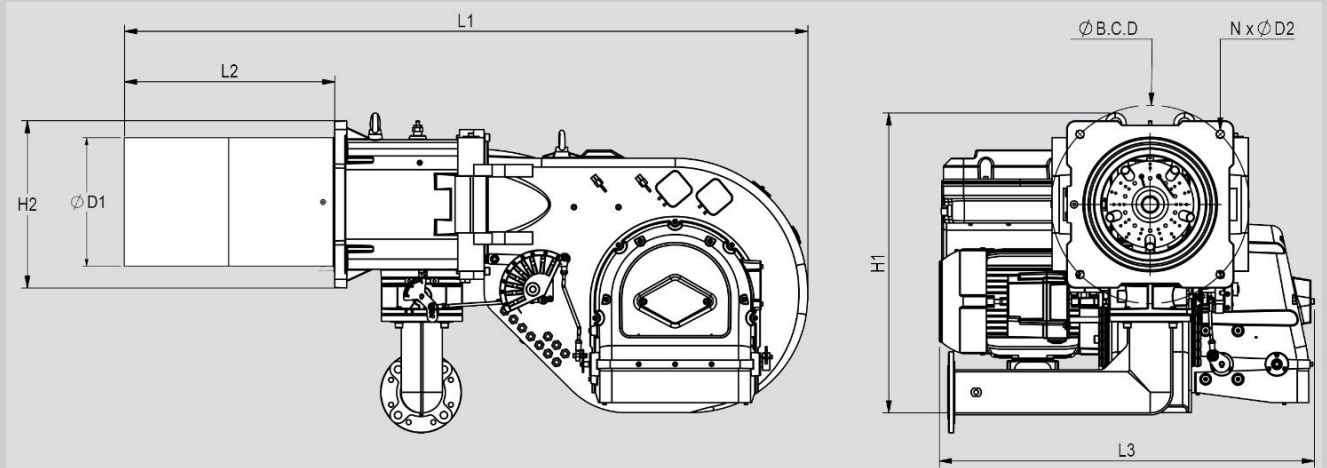

Burner Type	L ₁	L ₂	L ₃	H ₁	H ₂	D ₁	D ₂	N	B.C. D
RGB-MC-605	1665	502	1035	741	410	334	20	4	490



We are delighted to gratefully guarantee the best performance of our productions in order to meet our customer demands.

RLGB-MC series roadman burner:

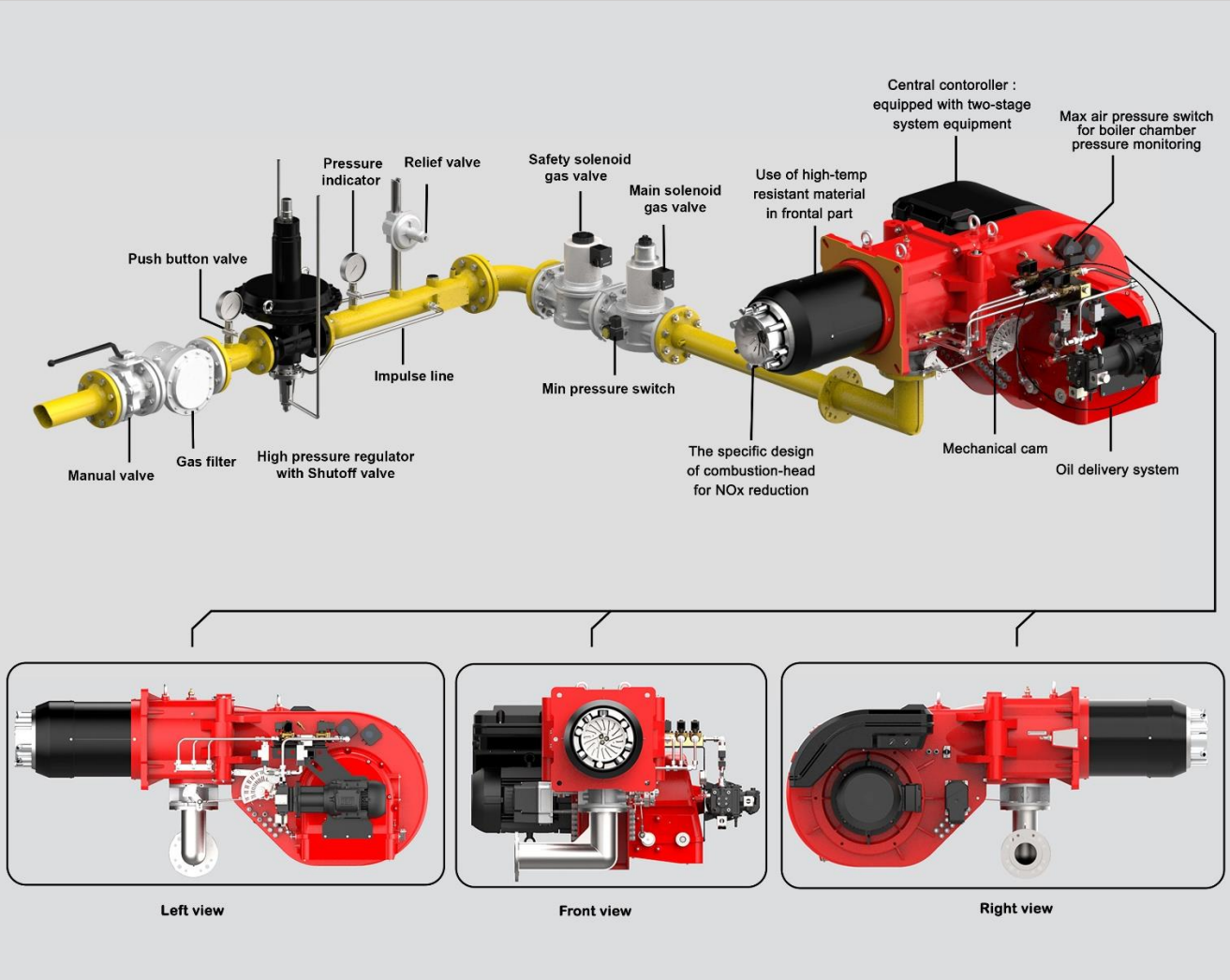

Burner selection: capacity and working diagram

Dual-fuel Burner

Burner	Capacity (KW)	Turn down	Burner	Capacity (kW)	Turn down
RLGB-MC-110	NG: 350-1100	1:3	RLGB-MC-175/LN	NG:320-1800	1:5
	LFO: 350-1100	1:3		LFO: 320-1800	1:5
RLGB-MC-145	NG: 400-1380	1:4	RLGB-MC-205/LN	NG:450-2200	1:5
	LFO:400-1380	1:4		LFO:450-2200	1:5

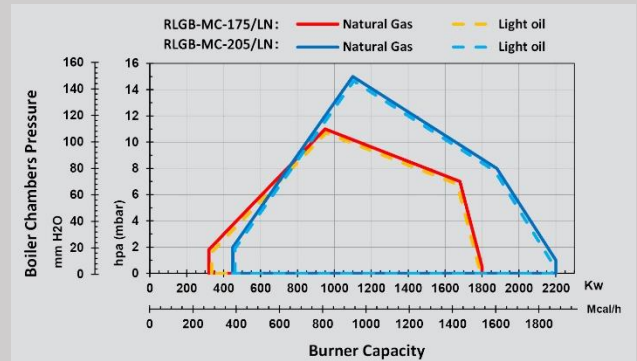
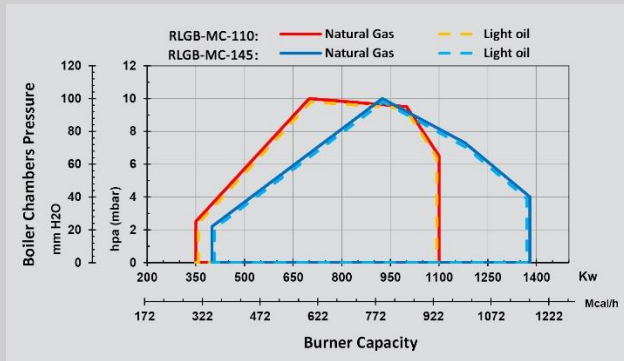

Burner	Capacity (kW)	Turn down	Burner	Capacity (KW)	Turn down
RLGB-MC-305/LN	NG:600-3000	1:5	RLGB-MC-405/LN	NG: 680-4100	1:6
	LFO: 600-3000	1:5		LFO: 680-4100	1:6
RLGB-MC-385/LN	NG:650-3500	1:5	RLGB-MC-505/LN	NG: 700-5100	1:7
	LFO:650-3500	1:5		LFO:700-5100	1:7

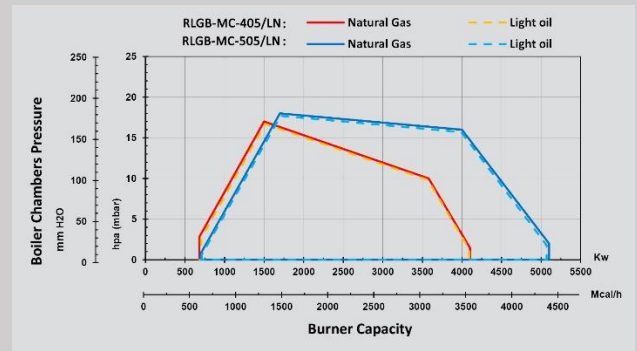
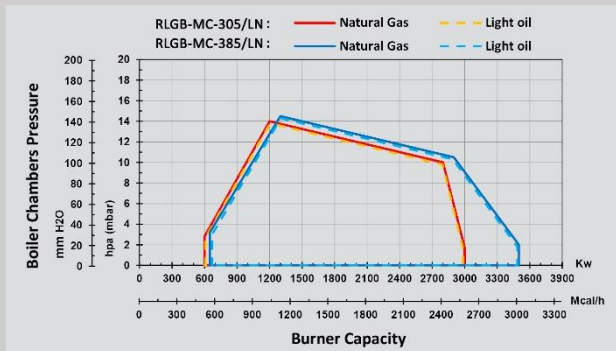

Burner	Capacity (KW)	Turn down	Burner	Capacity (KW)	Turn down
RLGB-MC-255	NG:580-2400	1:4	RLGB-MC-605/LN	NG: 1000-6100	1:6
	LFO:580-2400	1:4		LFO: 1000-6100	1:6

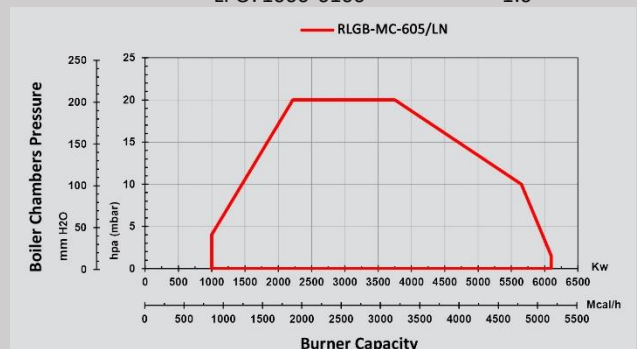
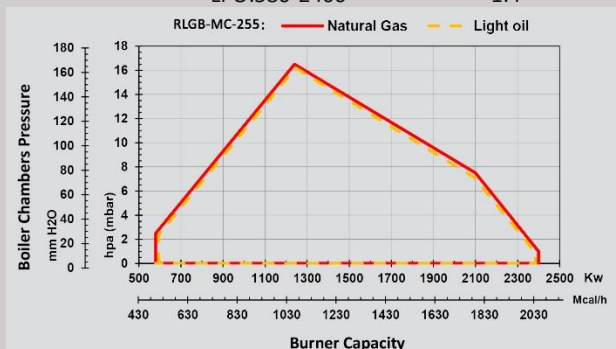

Working diagrams for light fuel oil burner are certified in accordance with BS-EN 267.

The firing rate diagram has been obtained considering the ambient temperature of 20°C and atmospheric pressure of 1013 mbar (Sea level condition).

Technical data: RLGB-MC series (Dual-fuel burner)

- N.G operation: Staging or Mechanical Modular
- LFO operation: II or III Stages

Burner	Power system		Power management system	
	Motor(kW/PH/V/HZ/rpm)		Controller	Actuator (N.M)
RLGB-MC-110	1.5 /3 /380-400 /50 /2840		Siemens/Honeywell	3/2.5
RLGB-MC-145	2.2 /3 /380-400 /50 /2840		Siemens/Honeywell	3/2.5
RLGB-MC-175/LN	4 /3 /380-400 /50 /2840		Siemens/Honeywell	3/3
RLGB-MC-205/LN	5.5 /3 /380-400 /50 /2840		Siemens/Honeywell	3/3
RLGB-MC-255	5.5 /3 /380-400 /50 /2840		Siemens/Honeywell	3/3
RLGB-MC-305/LN	7.5 /3 /380-400 /50 /2940		Siemens/Honeywell	3/3
RLGB-MC-385/LN	7.5 /3 /380-400 /50 /2940		Siemens	10
RLGB-MC-405/LN	11 /3 /380-400 /50 /2940		Siemens	10
RLGB-MC-505/LN	11 /3 /380-400 /50 /2940		Siemens	10
RLGB-MC-605/LN	15 /3 /380-400 /50 /2920		Siemens	10



General dimension of RLGB-MC series

RLGB-MC-110, RLGB-MC-145

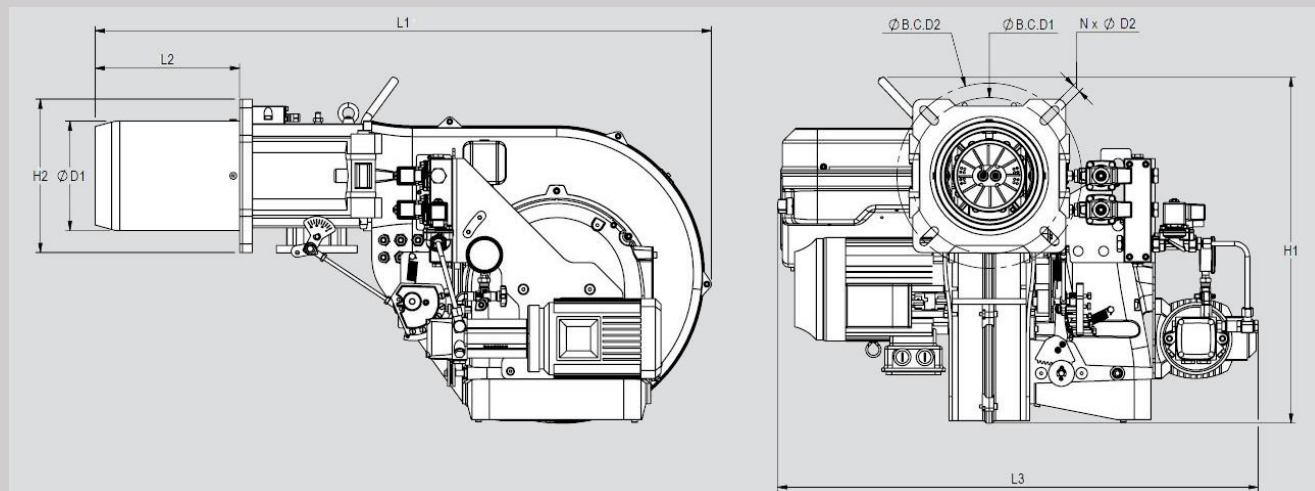

Burner Type	L ₁	L ₂	L ₃	H ₁	H ₂	D ₁	D ₂	N	B.C. D1	B.C. D2
RLGB-MC-110	1068	250	830	598	265	184	15	4	270	320
RLGB-MC-145	1068	255	830	598	265	194	15	4	270	320

RLGB-MC-175/LN, RLGB-MC-205/LN

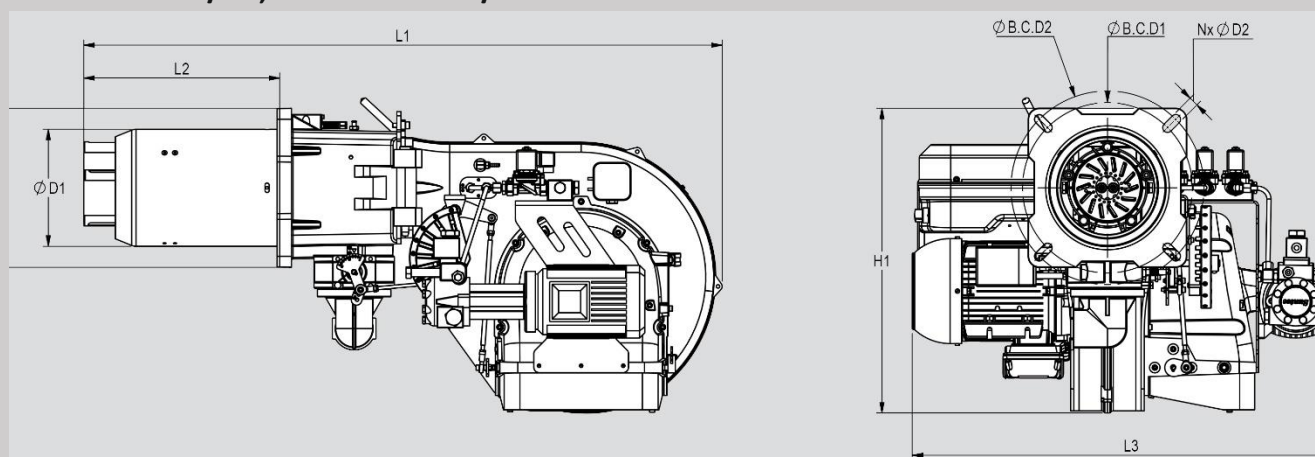

Burner Type	L ₁	L ₂	L ₃	H ₁	H ₂	D ₁	D ₂	N	B.C. D1	B.C. D2
RLGB-MC-175/LN	1213	373	875	598	300	226	18	4	323	367
RLGB-MC-205/LN	1213	373	875	598	300	226	18	4	323	367

RLGB-MC-255

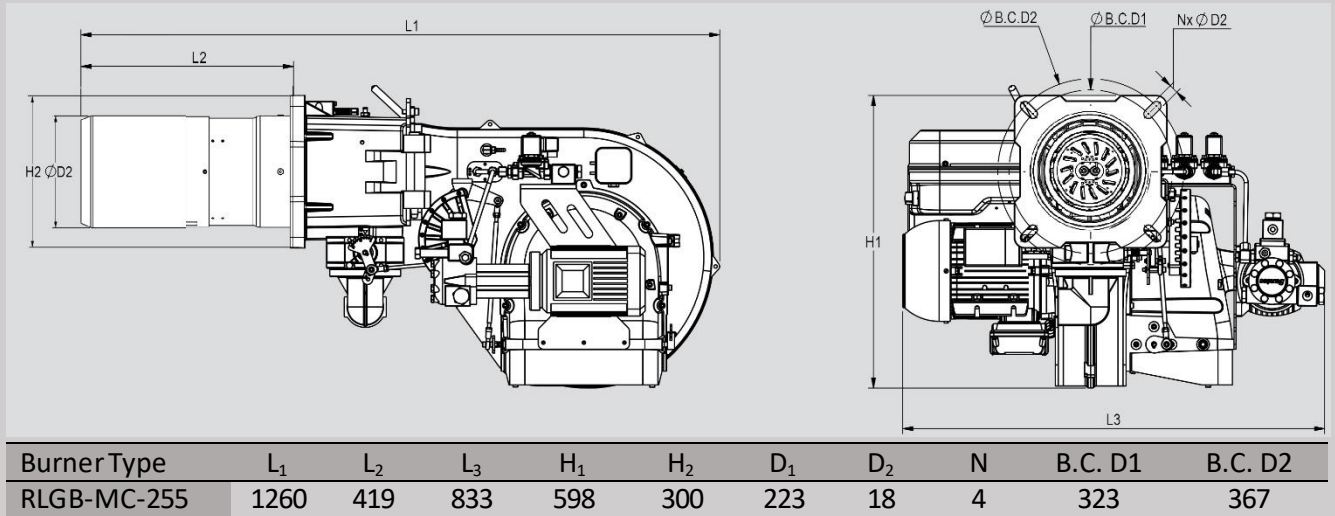

RLGB-MC-305/LN, RLGB-MC-385/LN, RLGB-MC-405/LN, RLGB-MC-505/LN, RLGB-MC-605/LN

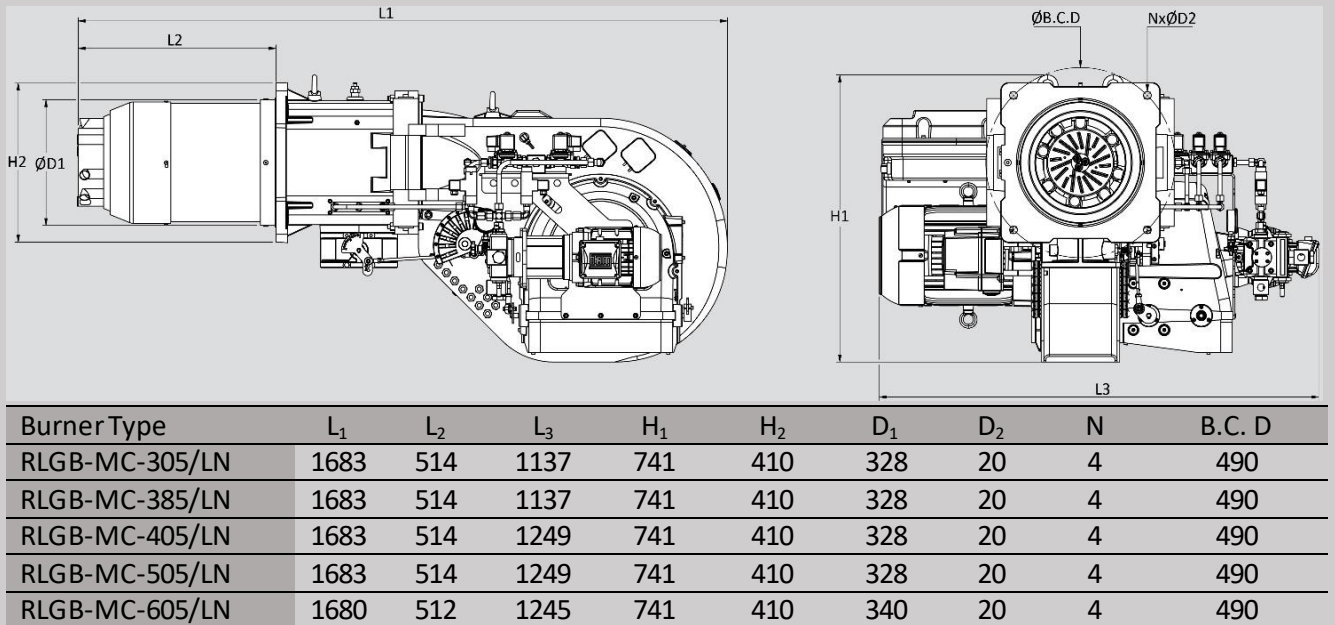

Gas train diagram:

GT1(Pressure input<500 mbar, separated items)

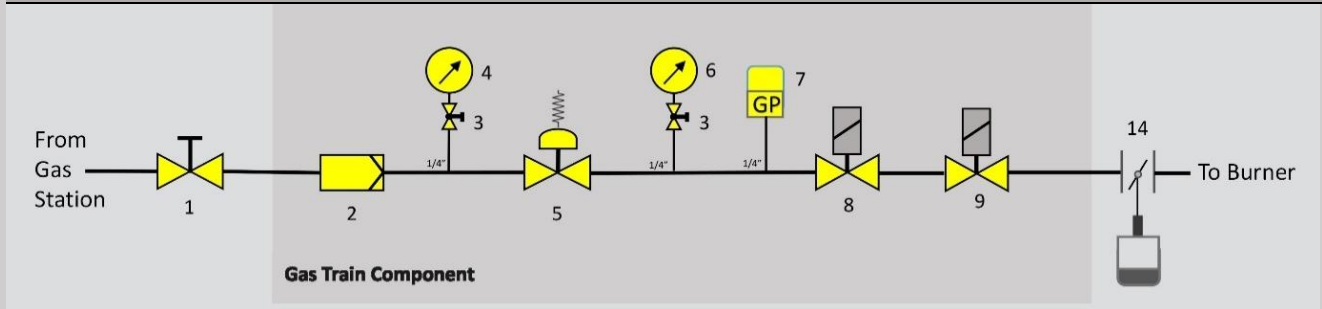

GT2 (Pressure input<500 mbar, multi bloc gas train)

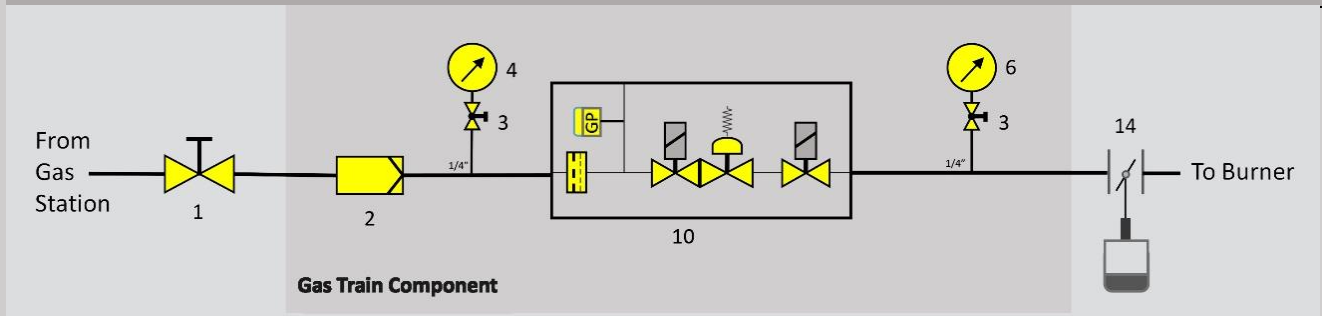

GT3 (Pressure input<500 mbar, separated items,with valve proving system)

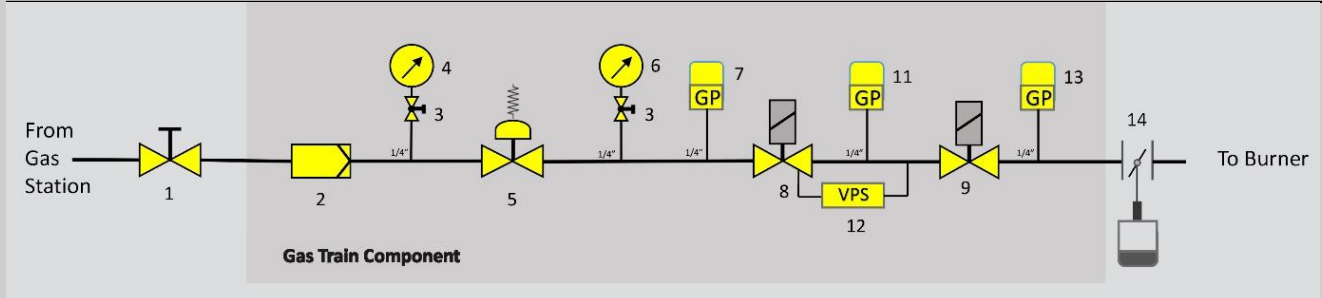

GT4 (Pressure input<500 mbar, multi bloc gas train, with valve proving system)

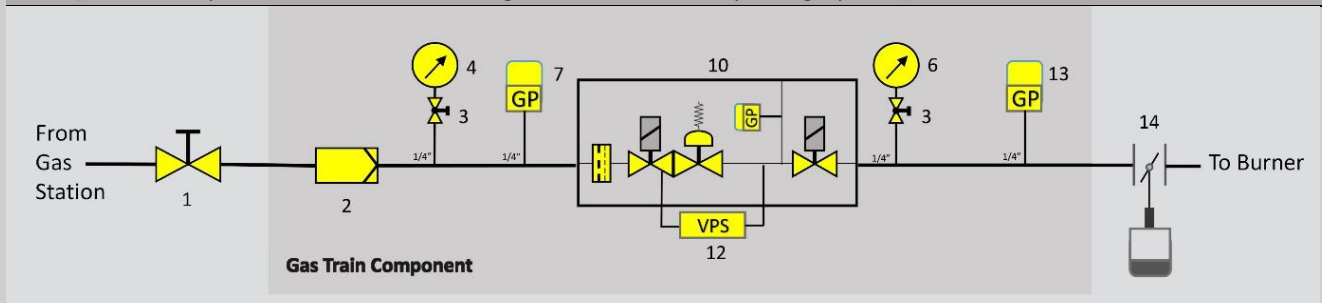

- | | | |
|--------------------------------------|--------------------------------|-----------------------------------|
| 1: Ball valve | 6: Pressure Gauge | 11: Leak Test gas pressure switch |
| 2: Gas filter | 7: Min gas pressure switch | 12: Valve proving system |
| 3: Ball valve | 8: Safety gas valve | 13: Max gas pressure switch |
| 4: Pressure Gauge | 9: Main gas valve | 14: Butterfly valve |
| 5: Pressure regulator (Low pressure) | 10: Multi-Block Solenoid Valve | |

Gas Valve Train Sizing

RGB-MC-Series...				
Burner	Gas model	Gas train size	ΔP B.V (mbar)	ΔP C.H** (mbar)
RGB-MC-85/LN	GT1/GT2	Rp 1 ½	2	11.7
RGB-MC-110	GT1/GT2	Rp 1 ½	2	9
RGB-MC-130/LN*	GT3/GT4	Rp 1 ½	2	22.5
RGB-MC-145*	GT3/GT4	Rp 2	2	8.6
RGB-MC-205	GT3/GT4	Rp 2	3	14.5
RGB-MC-255/LN	GT3/GT4	Rp 2	3	24.9
RGB-MC-305	GT3/GT4	DN 65	4	20.6
RGB-MC-385	GT3/GT4	DN 65	4	31.7
RGB-MC-405/LN	GT3/GT4	DN 65	4	47
RGB-MC-505/LN	GT3/GT4	DN 65	4	56
RGB-MC-605	GT3/GT4	DN 65	4	62.8

RLGB-MC-Series				
Burner	Gas model	Gas train size	ΔP B.V (mbar)	ΔP C.H** (mbar)
RLGB-MC-110	GT1/GT2	Rp 2	2	10
RLGB-MC-145*	GT3/GT4	Rp 2	2	13
RLGB-MC-175/LN*	GT3/GT4	Rp 2	3	17
RLGB-MC-205/LN	GT3/GT4	Rp 2	3	21.5
RLGB-MC-255	GT3/GT4	Rp 2	4	27.8
RLGB-MC-305/LN	GT3/GT4	DN 65	4	23
RLGB-MC-385/LN	GT3/GT4	DN 65	4	27.3
RLGB-MC-405/LN	GT3/GT4	DN 65	4	44
RLGB-MC-505/LN	GT3/GT4	DN 65	4	47
RLGB-MC-605/LN	GT3/GT4	DN 65	4	68

* Max gas pressure switch is optional

** Combustion Head

Note:

According to the BS-EN 676, valve proving system shall be used in burners with capacity above 1.2 MW. Consequently, MADAS-MTC10 or DungsVDK200 valve proving system are highly recommended.

Layout of the valve train

On boilers with hinged doors, the valve train must be mounted on the opposite side to the boiler door hinges.

Break points in the valve train

Break points in the valve train should be provided to enable the door of the heat generator to be swung open. The main gas line is best separated at the compensator.

Support of the valve train

The valve train should be properly supported in accordance with the site conditions. See the radman accessories list for various valve train support components.

Calculation of Minimum Inlet Pressure and Minimum output pressure of regulator

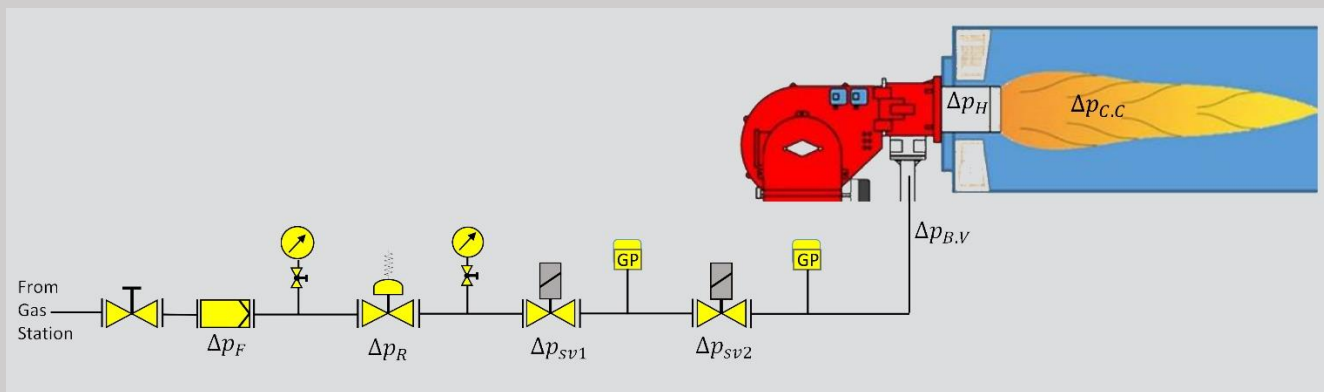

Min Input Pressure= $\Delta P_{\text{Filter(F)}} + \Delta P_{\text{Regulator(R)}} + \Delta P_{\text{Safety solenoid valve(sv1)}} + \Delta P_{\text{main solenoid valve(sv2)}} + \Delta P_{\text{butterfly valve(B.V)}} + \Delta P_{\text{Combustion Head(H)}} + \Delta P_{\text{Combustion chamber(C.C)}}$

Min output pressure of regulator= $\Delta P_{\text{Safety solenoid valve(sv1)}} + \Delta P_{\text{main solenoid valve(sv2)}} + \Delta P_{\text{butterfly valve(B.V)}} + \Delta P_{\text{Combustion Head(H)}} + \Delta P_{\text{Combustion chamber(C.C)}}$



Oil delivery system

Type OL-III: (Two Stages dual-fuel burner)

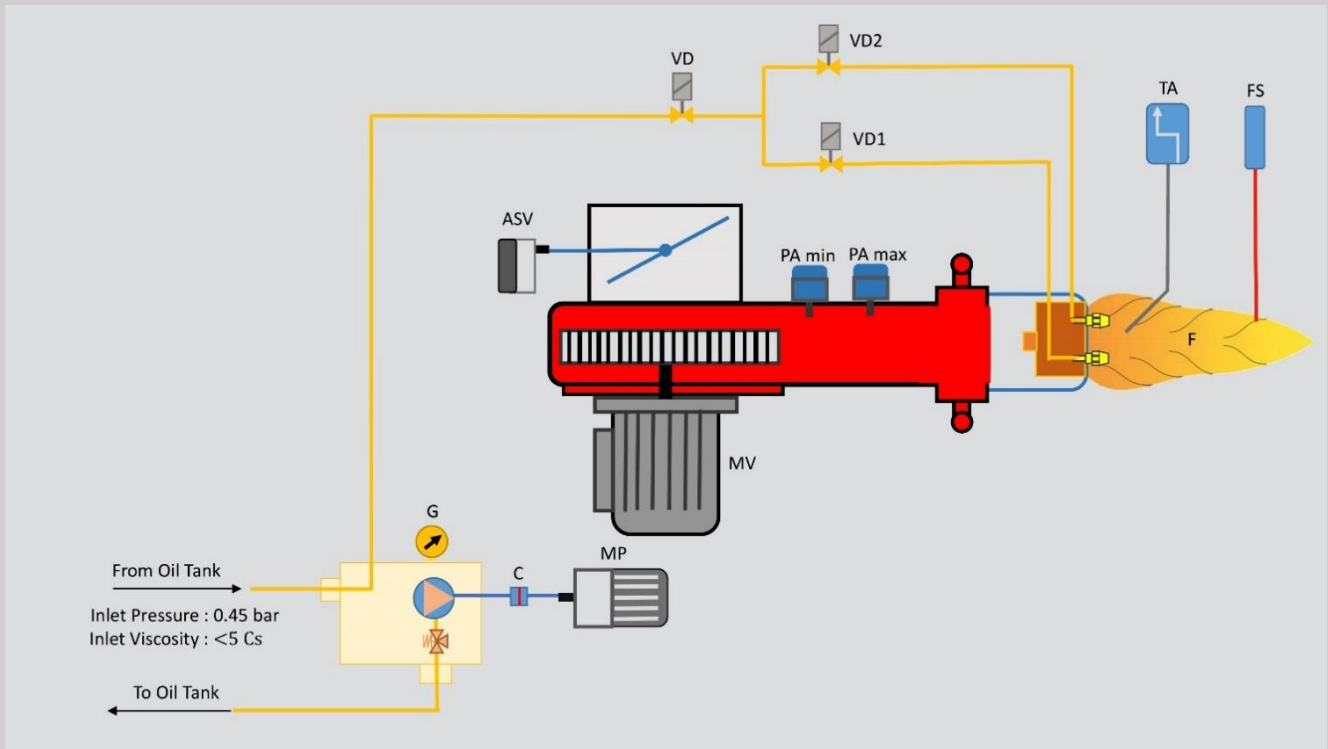

Type OL-III: (Three Stages dual-fuel burner)

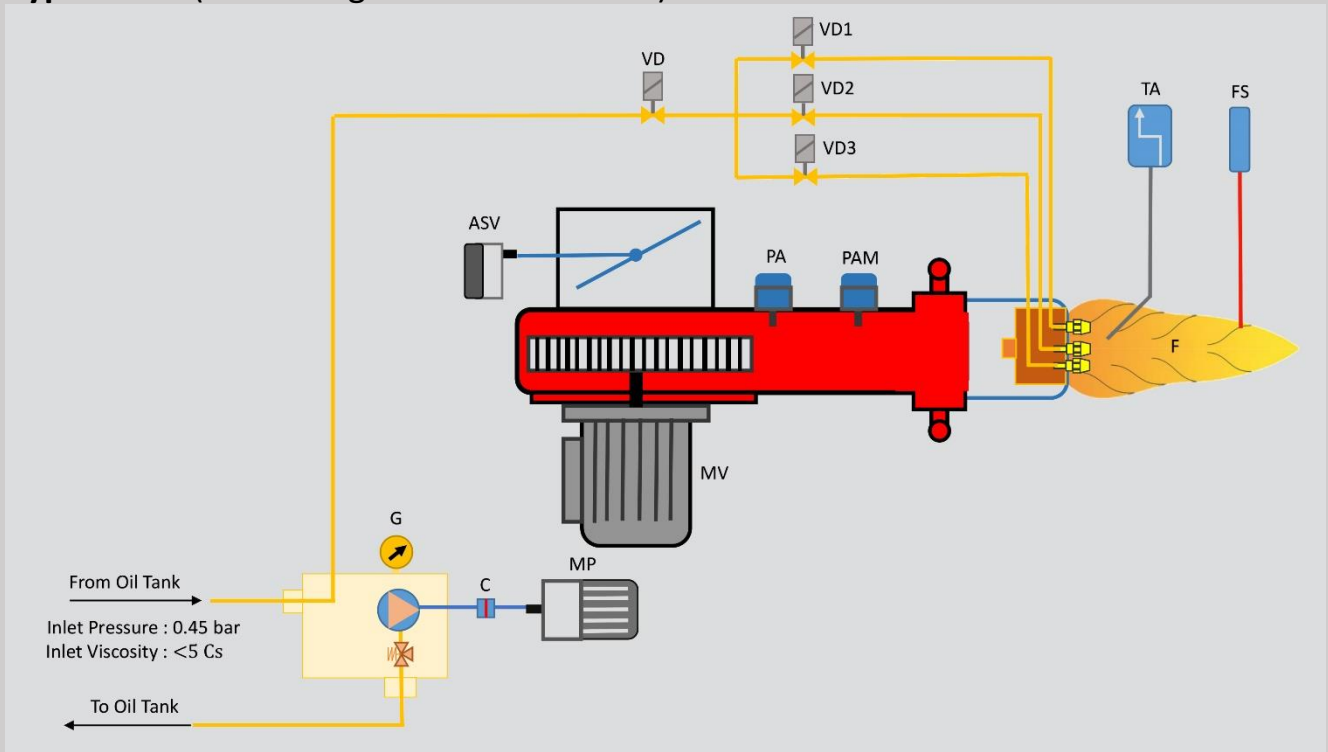

MV: Fan motor
 MP: Pump motor
 FS: Flame sensor
 VD: Light oil safety valve

VD1: Light oil delivery valve Stage 1
 VD2: Light oil delivery valve Stage 2
 VD3: Light oil delivery valve Stage 3
 TA: ignition transformer

C: Coupling
 G: Gauge
 F: Gas or oil flame
 ASV: Air damper servomotor
 PA: Air pressure switch

Emission

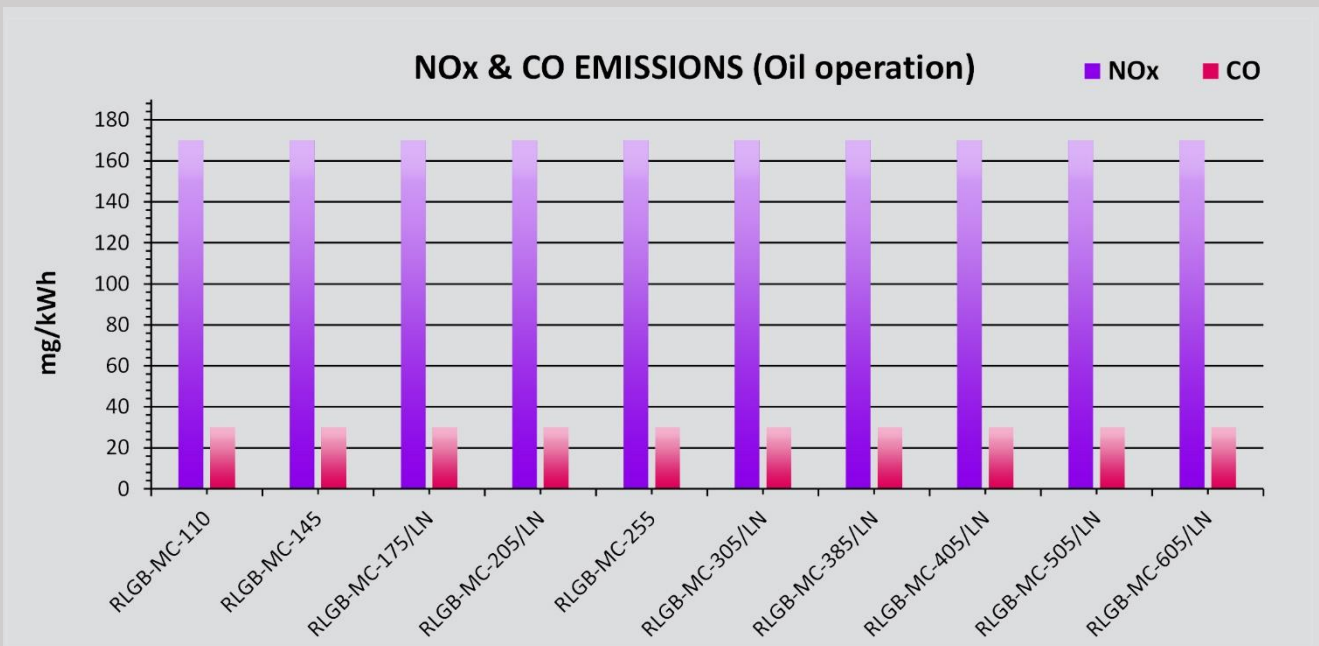
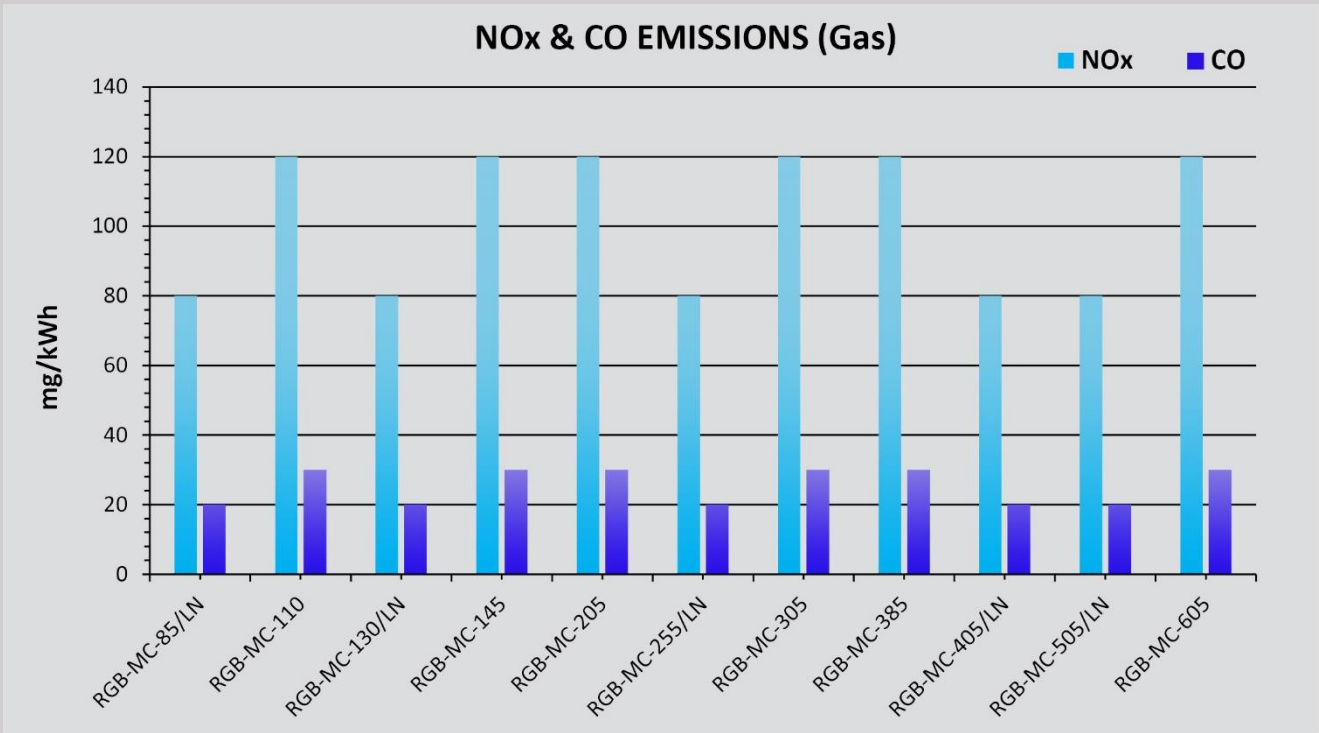

Mechanical Modular Burners cover a firing range of 1000 up to 6,200 kW generally. They can be used wherever heat is needed in heating residences or hospitals, schools or offices, in industry or trade, on board ships and for mobile plant. They are suitable for all commonly available gas and oil types and are notable for their superior reliability, longevity, great economy and ease of maintenance.



PACKMAN

Industrial Group

Web: www.packmangroup.com

Web: www.raadmanburner.com



[packmangroup.co](https://www.instagram.com/packmangroup.co)
[raadman.burner](https://www.instagram.com/raadman.burner)

Head office: 79 No. 10 Street, Bokharest Ave. Tehran, Iran.

Tel: (+98) 021 42 362, (+98) 021 88739075-9, 88731618

Fax: (+98) 021 88737131

Burner Factory: No.5, 102 ave. Montazeriye Industrial town,
Vilashahr, Isfahan, Iran

Technical and sale consultant:

Tel: (+98) 031 4229 0483

Mobile: (+98) 913 460 5664

Email: vah.azizi@gmail.com

