

- raadman -  
Burner

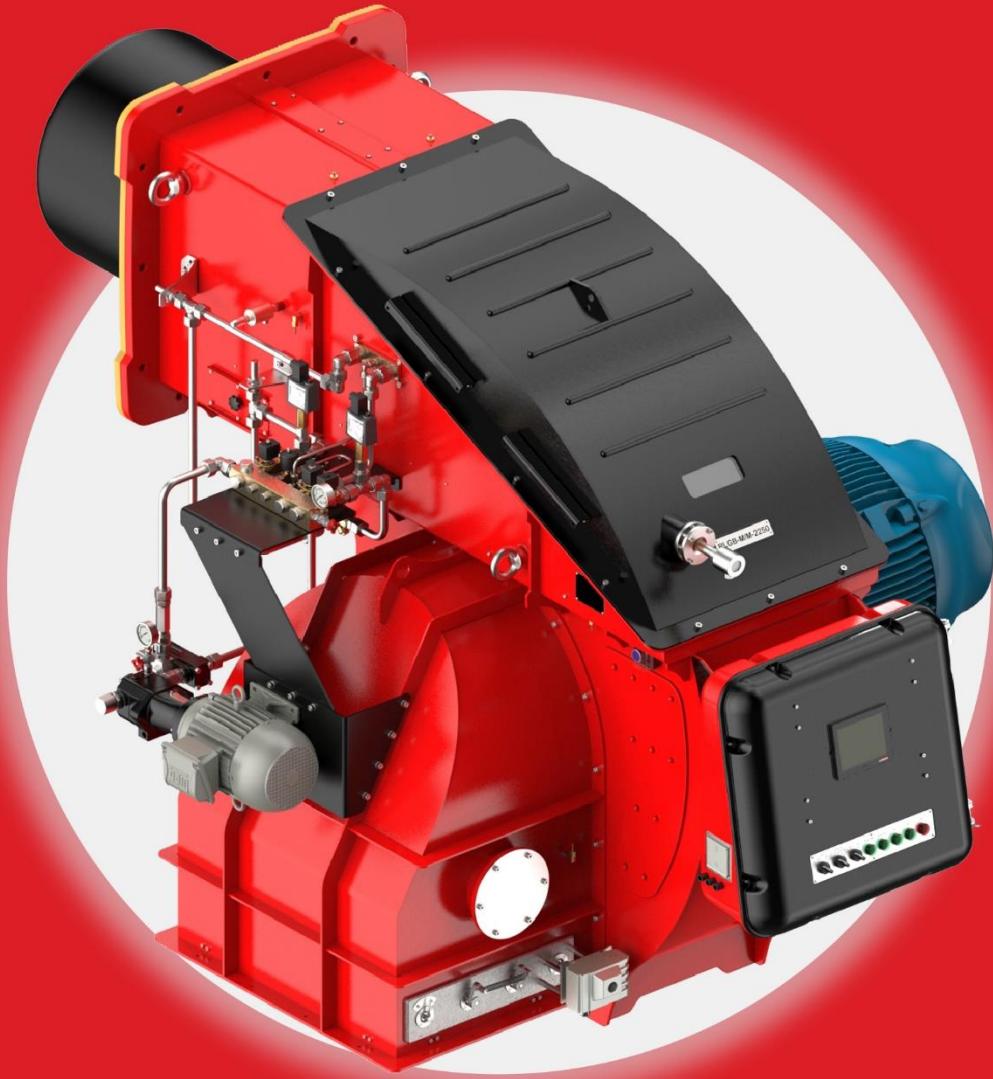

**General Catalogue**

Last Update  
**February 2024**

# PACKMAN

GREENMAN

ROMAN

- raadman -

CHILIMAN





## **PACKMAN Product Marketing**

<b>Uzbekistan</b>	<b>Nakhchivan</b>
<b>Turkmenistan</b>	<b>Libya</b>
<b>Tajikistan</b>	<b>Egypt</b>
<b>Afghanistan</b>	<b>Iraq</b>
<b>Malaysia</b>	<b>Saudi Arabia</b>
<b>Qatar</b>	<b>Tanzania</b>
<b>U.A.E</b>	<b>Colombia</b>
<b>Azerbaijan</b>	<b>Russia</b>
<b>Armenia</b>	<b>Kazakhstan</b>
<b>Republic of Belarus</b>	<b>Oman</b>



PACKMAN Company was established in February 1975. The company started its activity in the field of construction of High-Pressure Vessels such as Hot-Water Boilers, Steam Boilers, Pool Coil Tanks, Softeners and Heat Exchangers since 1984. As the first supplier of Hot water boilers with high quality and standard mark, PACKMAN has started exporting its products to countries such as Uzbekistan, The United Arab Emirates and other countries in surrounding nations. Currently, PACKMAN is one of the largest producers of hot-water and steam boilers in the Middle East.. After 40 years of experience in the field of heating industry, especially boilers and burners, the company started its activity in the field of burners under the brand name raadman in January 2011. The main objective of this team was improvement and development of industrial burners in order to produce high quality and highly efficient industrial burners with optimum operation in the Middle East.

PACKMAN Corporation started to produce industrial burners in different sizes (small, medium, and large) based on technical and engineering design. By efforts of engineers in R&D department, the burner s' combustion improved significantly. So, the production speed has been increased. Currently, the burners of this company cover a firing range of 100 to 60000 kW. Single stage, double stage, mechanical staging, mechanical modular, electronic modular and Low NOx burners (generally lower than 80 mg/kWh and individually lower than 40 mg/kWh) are available for various domestic and industrial applications. High quality, optimum operation and customer satisfaction has always been considered in the production of raadman burners. Diversity and high quality of raadman burners in addition to their easy installation and maintenance make them a perfect choice for many customers

[www.packmangroup.com](http://www.packmangroup.com)

[www.raadmanburner.com](http://www.raadmanburner.com)



- r a a d m a n —

- SMILE INTO THE FUTURE —



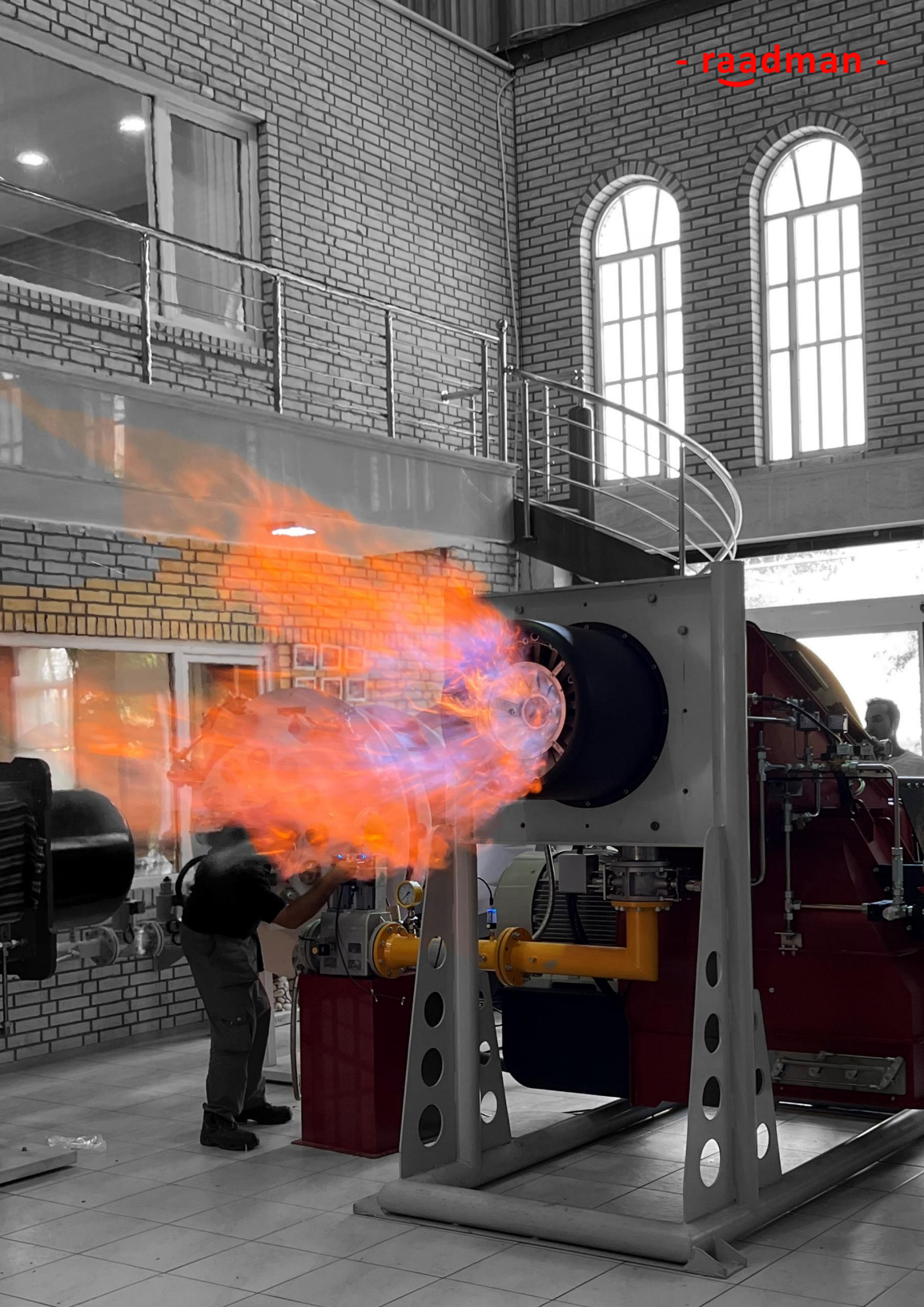

# How to use this catalogue

---



## Page 11 Range of products

In this section you can select the product by operation, fuel, and series. This index consists of bar charts showing minimum and maximum output of each series. Low NOx series is a green plus fuel colors.

---



## Page 19 Index

In this section you can select the product by operation, fuel, and series. Each series consist of:

- Pictures
  - Series name
  - Models in the series
  - Output range of category
  - Technical sheet page number.
- 



## Page 25 Burner data sheets section

This section contains the technical sheets of burners Including capacity diagram, dimensions, technical data, electrical operation diagram, gas train diagrams, and emission diagram.

---



## Page 230 Research & Development

This section contains new technologies, burners and an introduction to R&D department and technical information such as Flame Dimension, Low NOx burners, FGR System.

---



## Page 244 Request for information

For more technical information about raadman burners, you can refer to a special form.

---

# R LGP B-M/M-705/LN-DB-SF-F-FGR

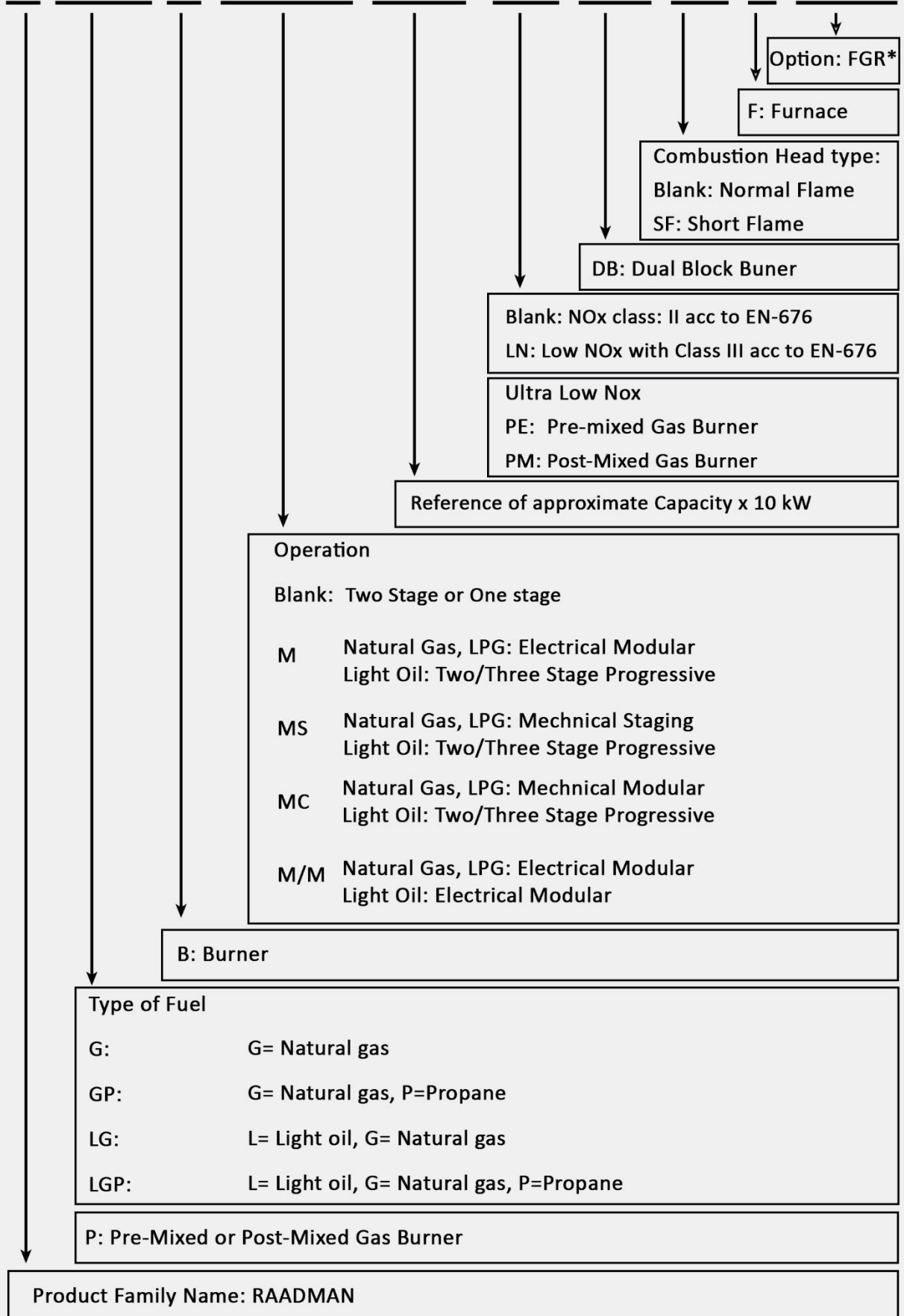

\*FGR: Flue Gas Recirculation



AN, as a designer, manufacturer  
of reverse osmosis  
systems





aa

- SMILE INTO THE FUTURE -







**We are trying to do our best in warming up your house  
in small and large scales.**

[www.raadmanburner.com](http://www.raadmanburner.com)



## Staging Mono Block Burners

### Gas burners (RGB series):

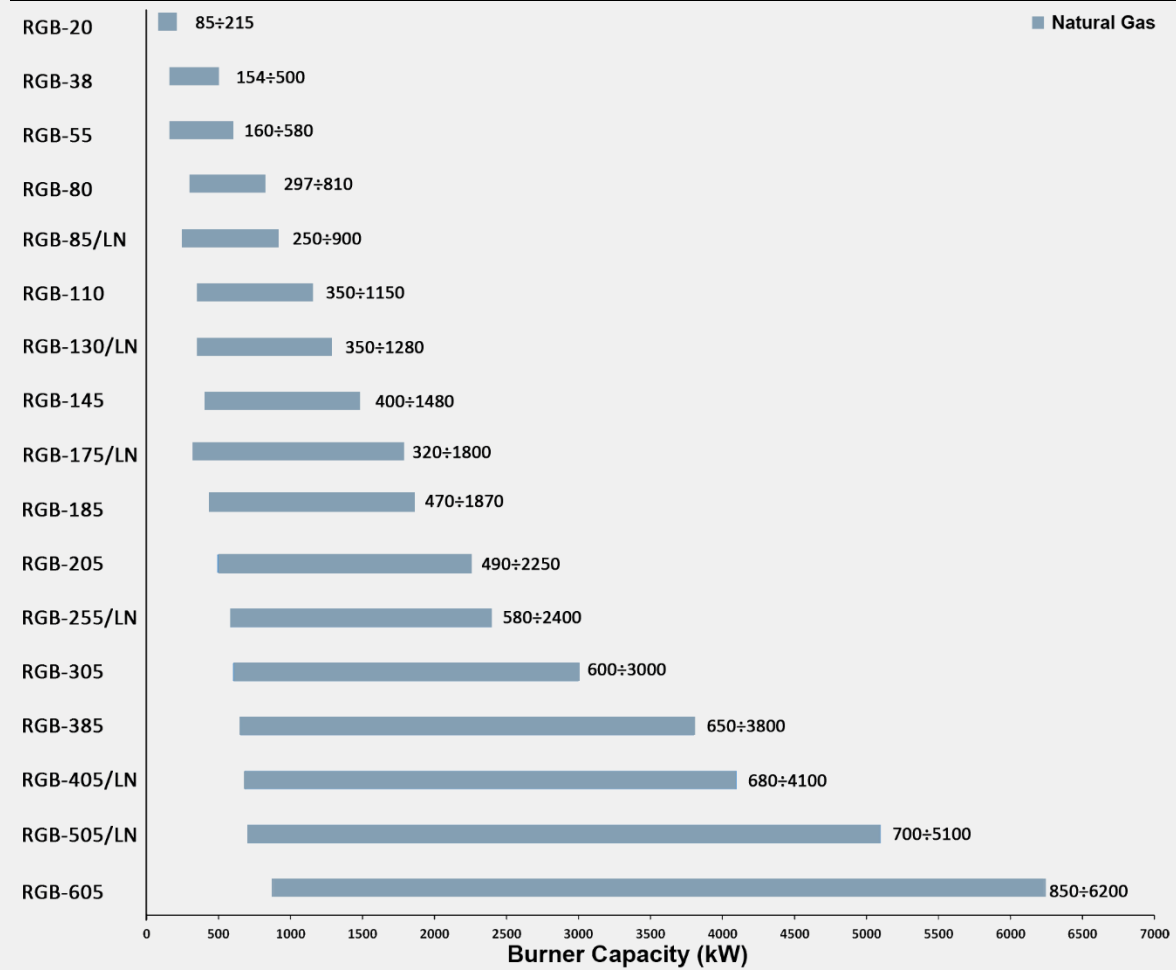

### Dual fuel burners (RLGB series):

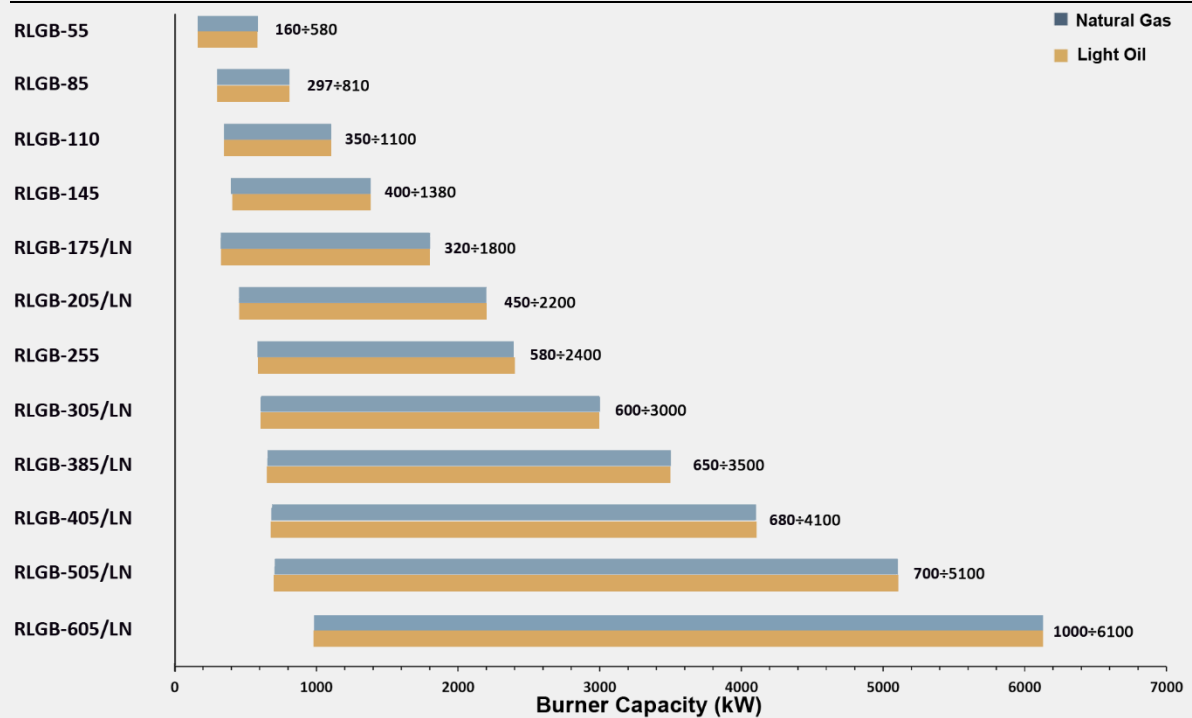

## Mechanical Staging Mono Block Burners

### Gas burners (RGB-MS series):

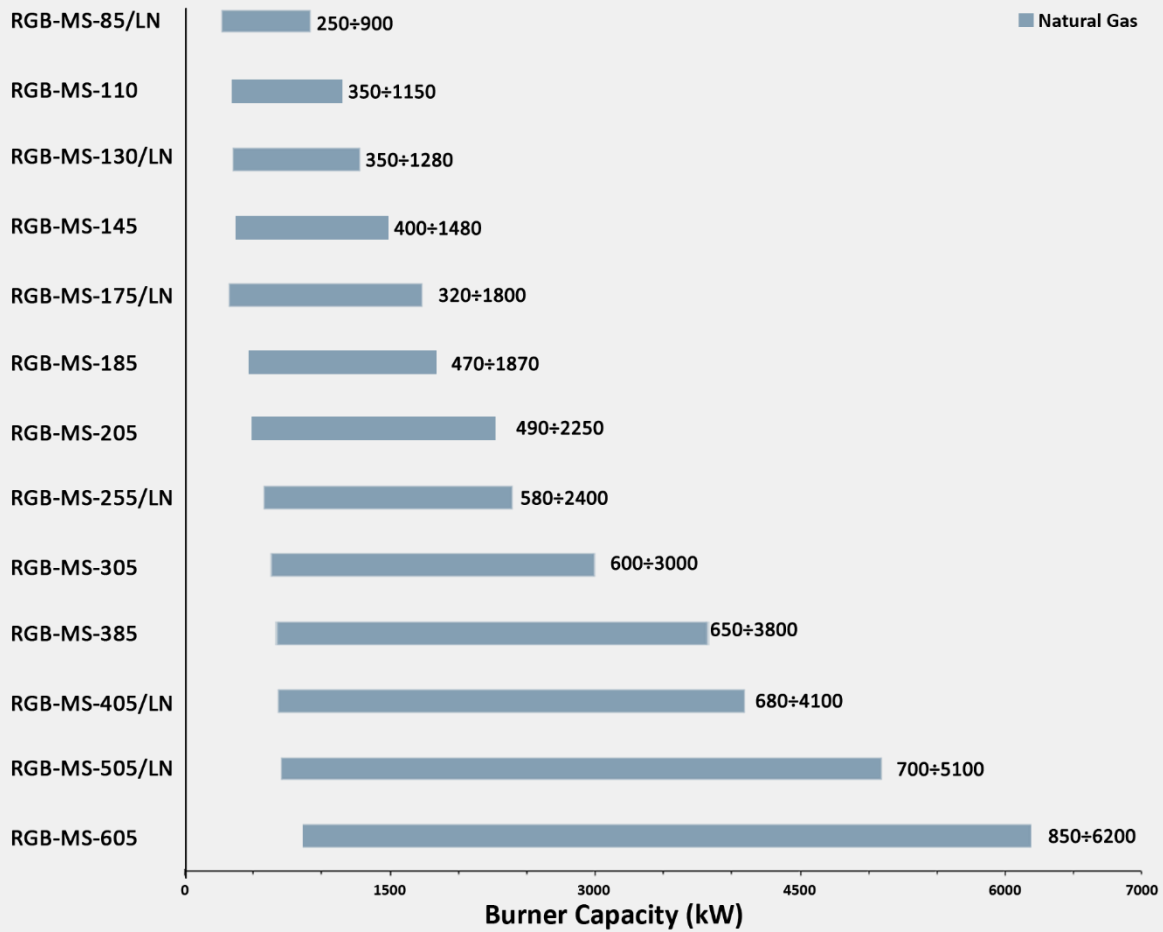

### Dual fuel burners (RLGB-MS series):

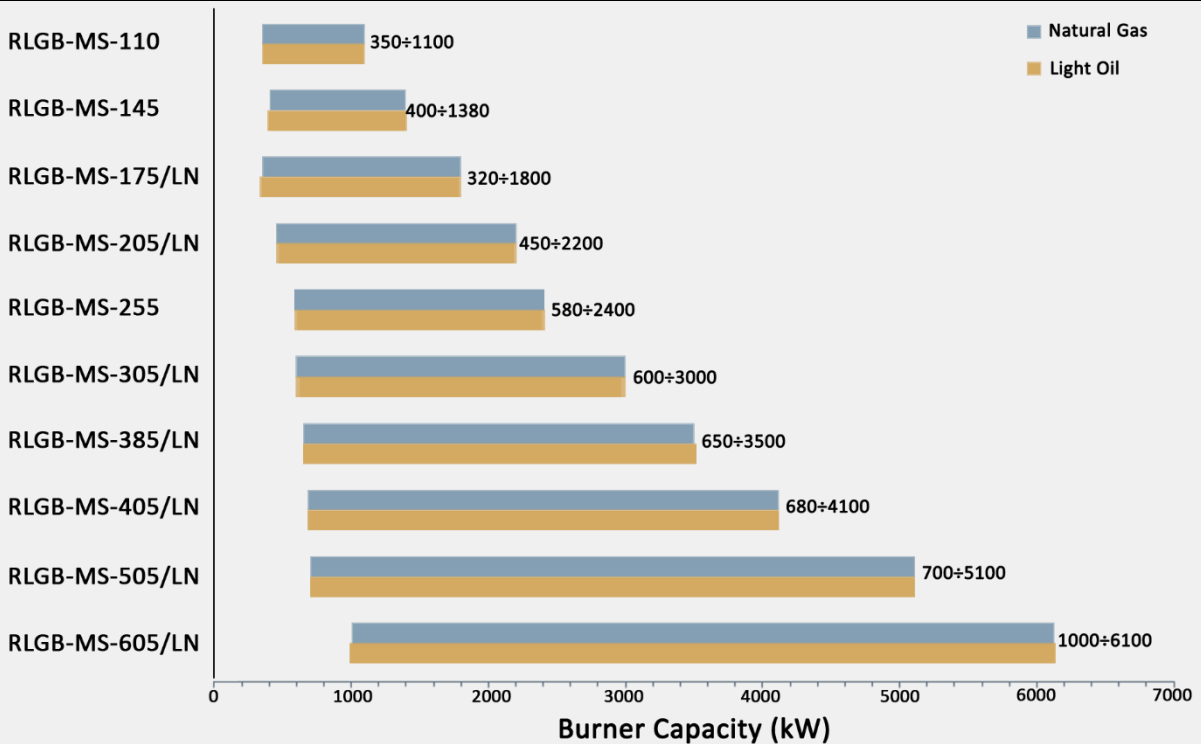





## Mechanical Modular Mono Block Burners

### Gas burners (RGB-MC series):

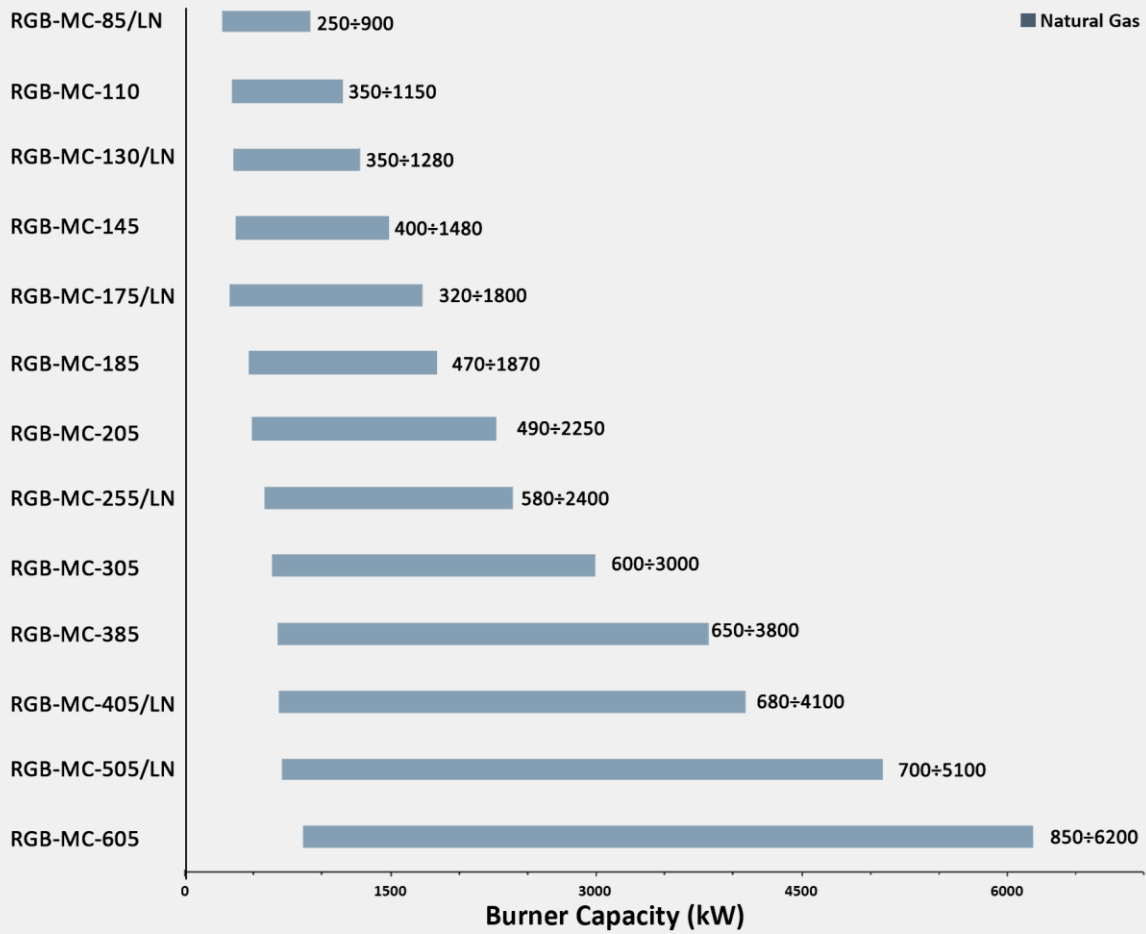

### Dual fuel burners (RLGB-MC series):

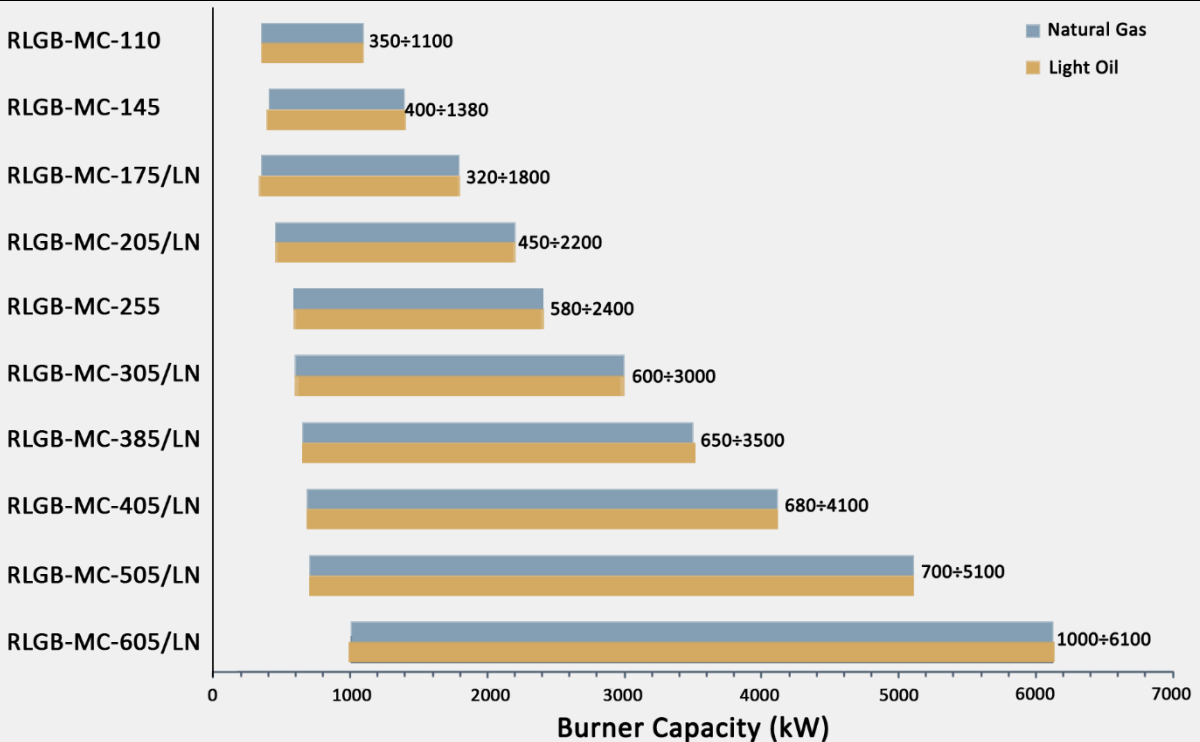



# Electronic Modular Mono Block Burners

## Gas burners (RGB-M series):

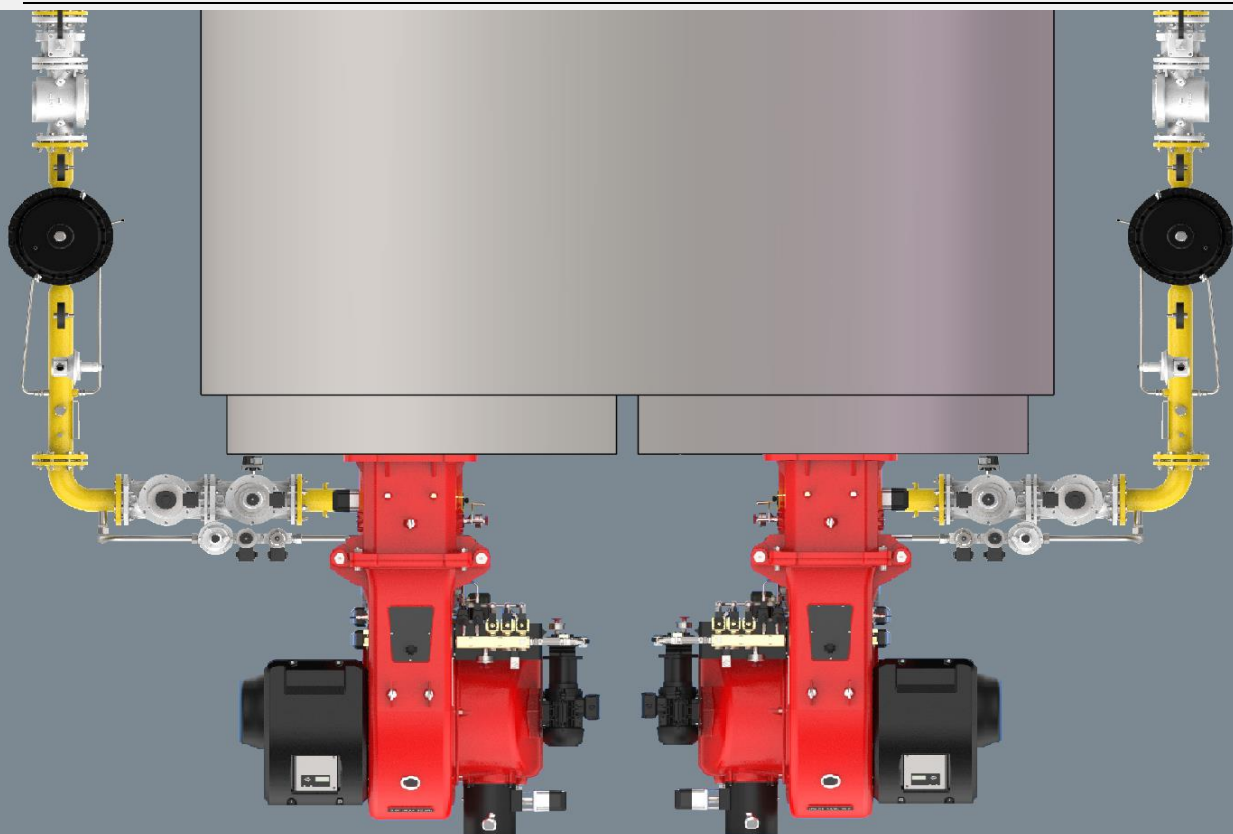
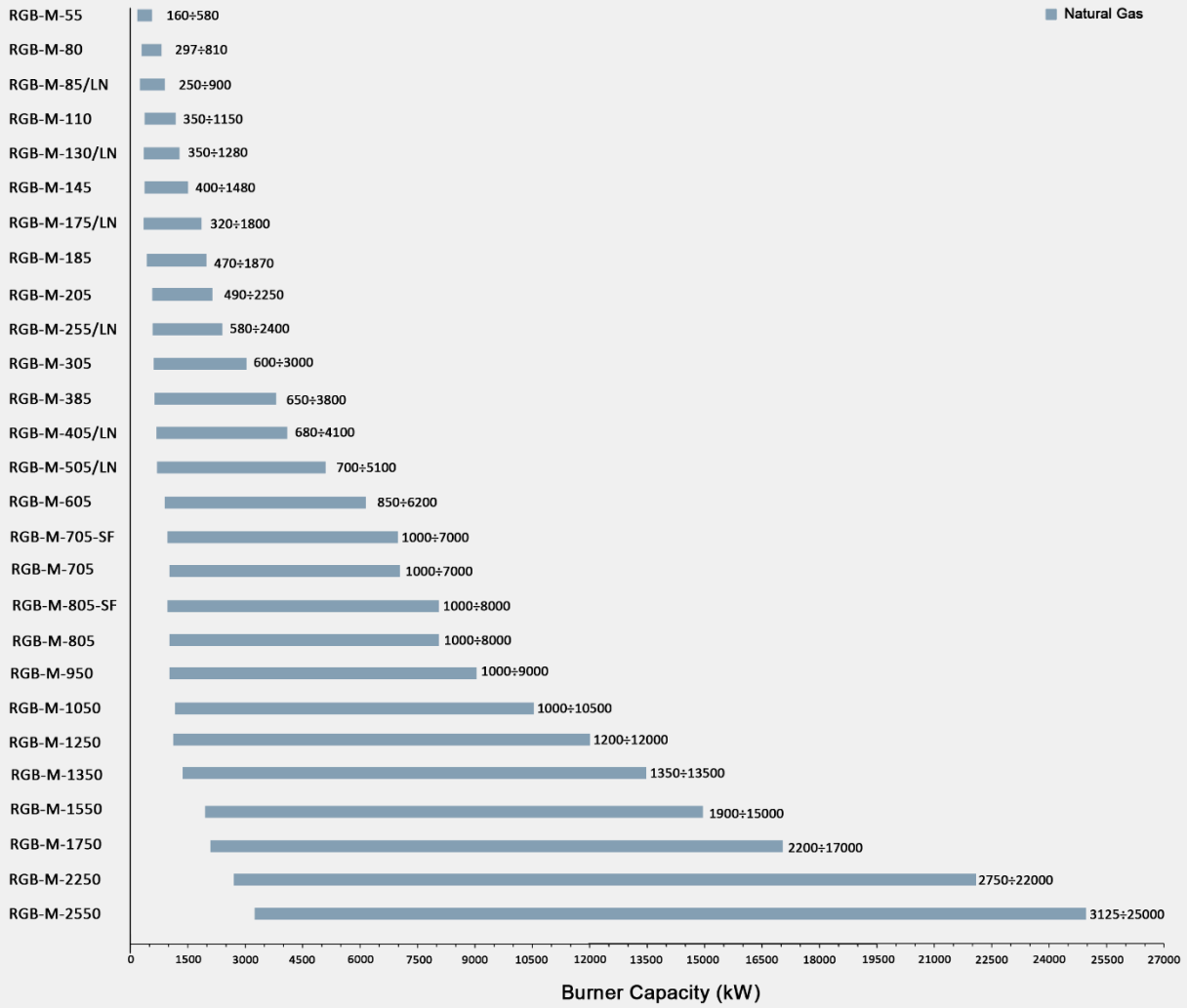



## Electronic Modular Mono Block Burners

### Dual fuel burners (RLGB-M series):

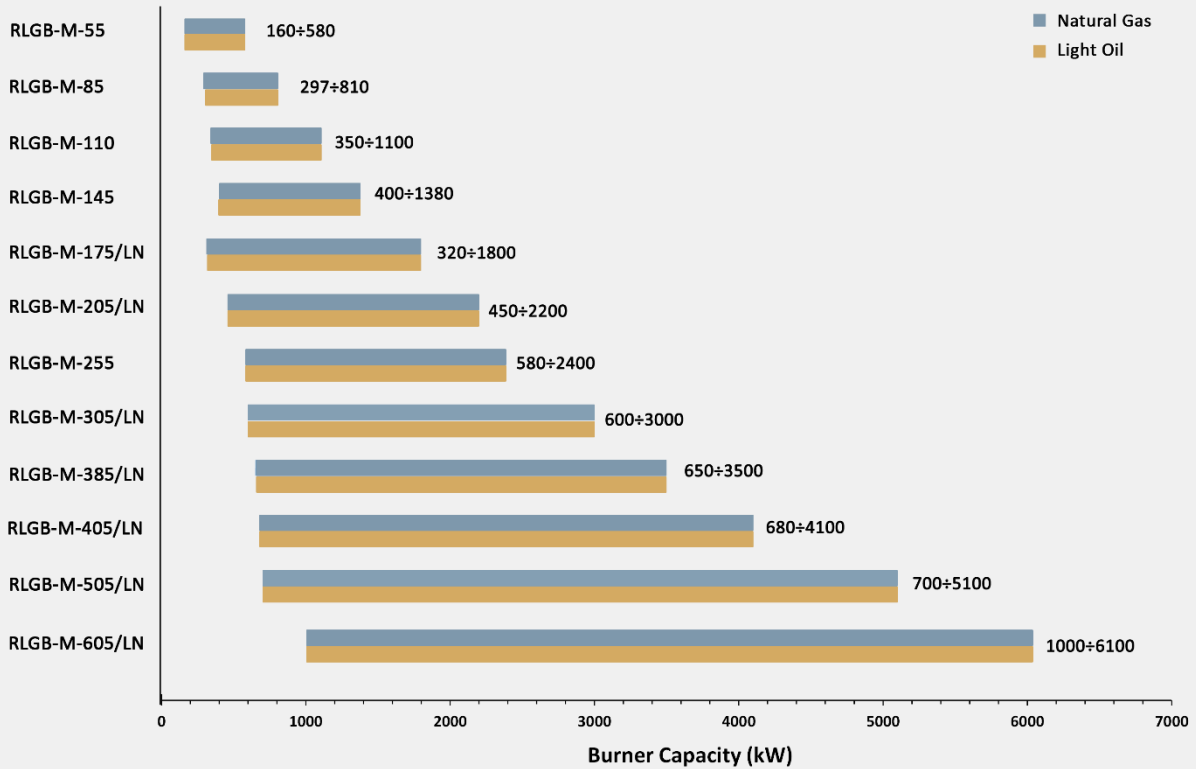

### Dual fuel burners (RLGB-M/M series):

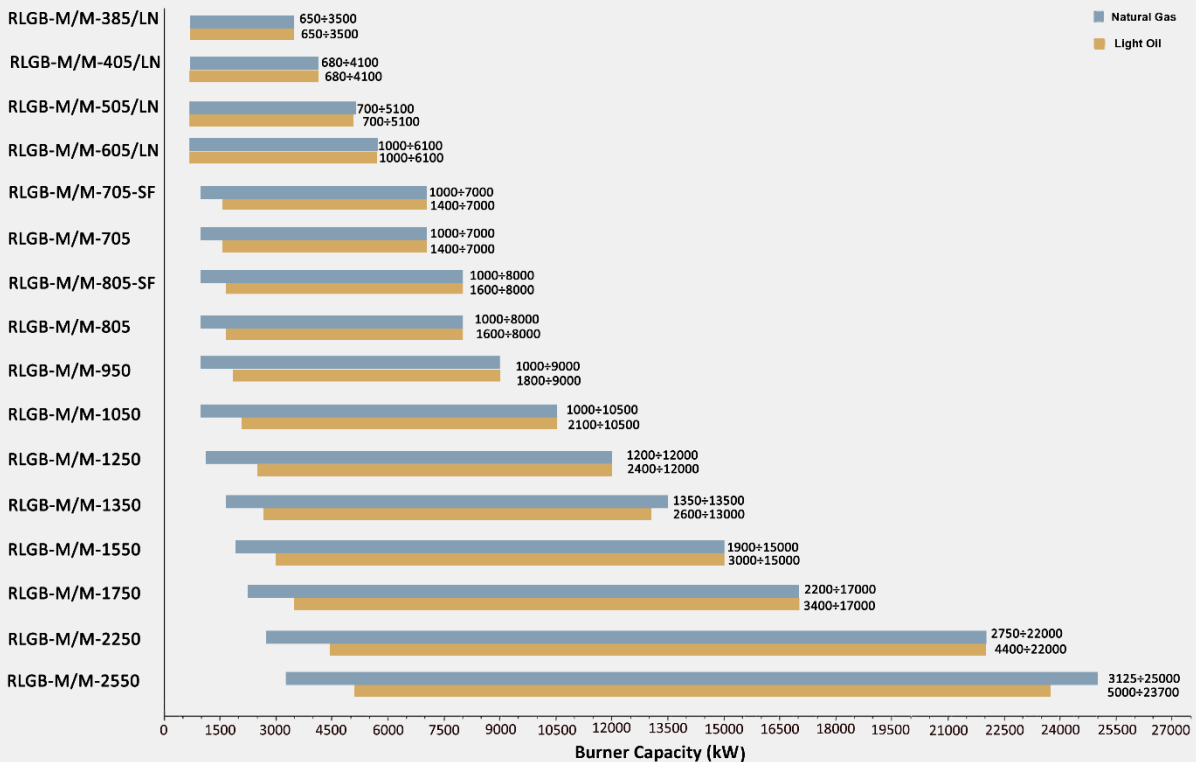

## Premixed Burners

### Pre-Mixed burners (PE series):

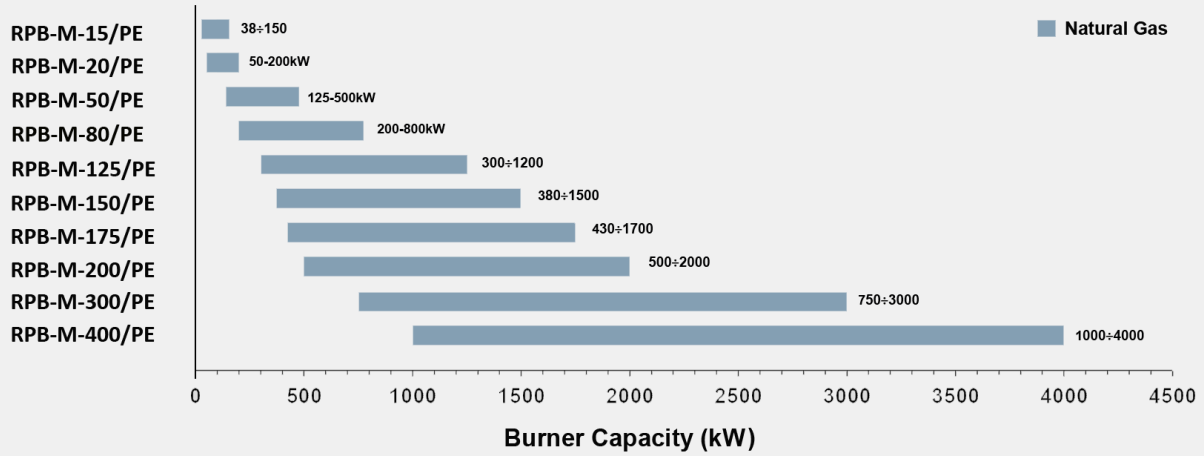

### Post-Mixed burners (PM series):

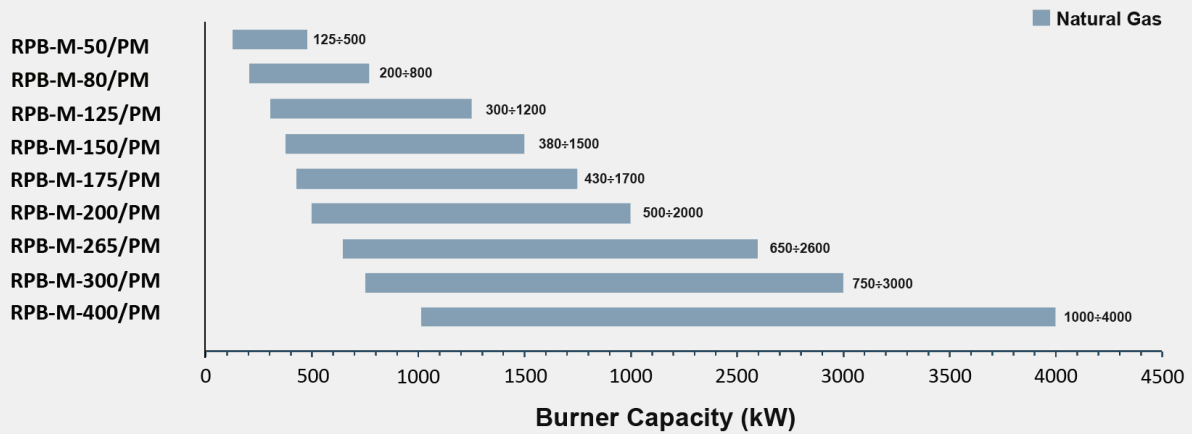



## Dual Block Burners

### Gas burners (RGB-M-X-DB series):

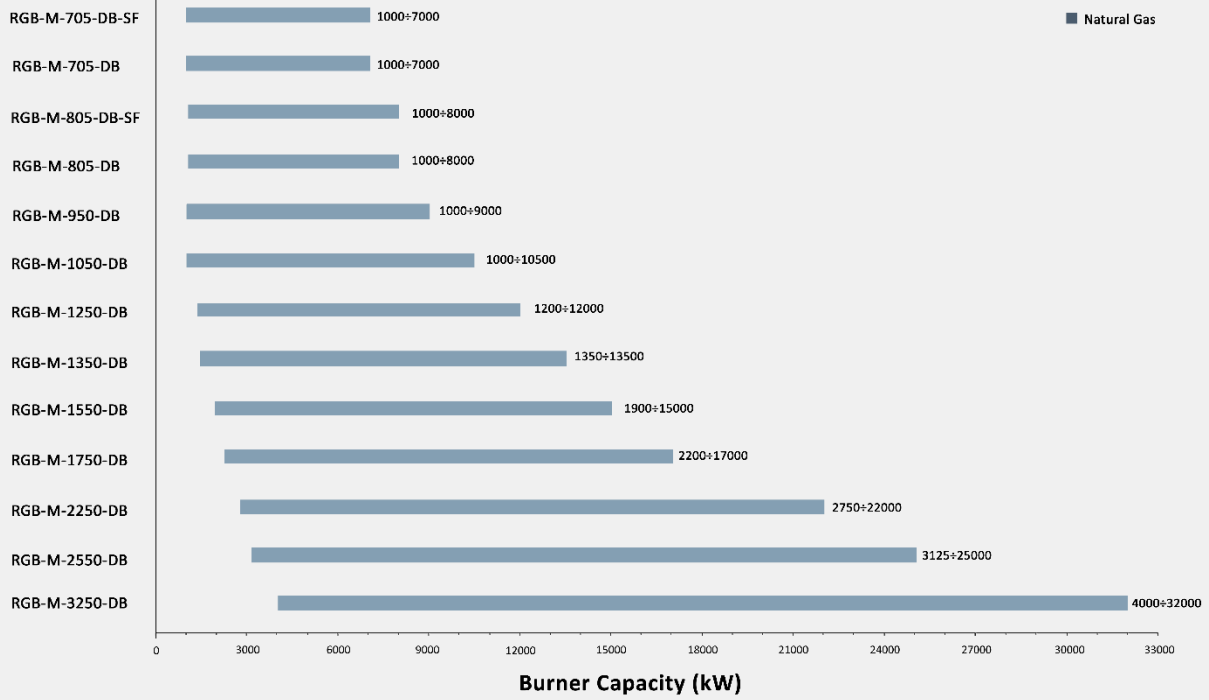

### Dual fuel burners (RLGB-M/M-X-DB series):

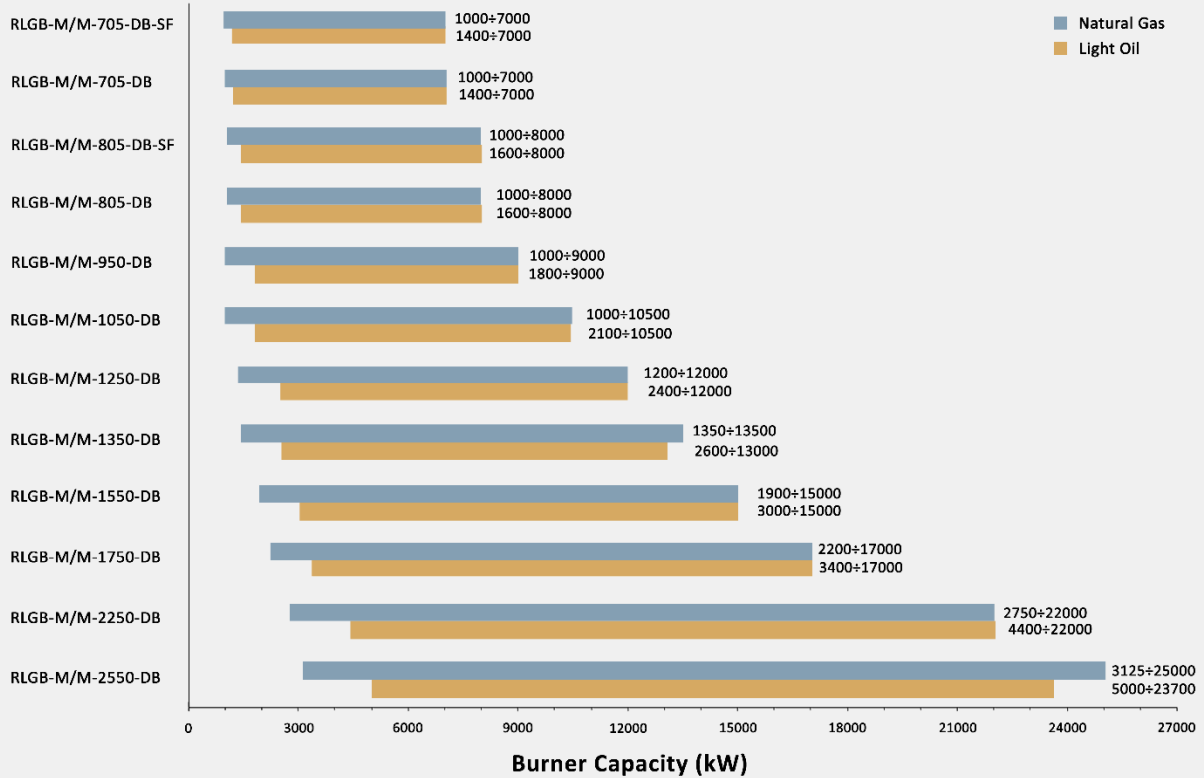



Dual Block Burner

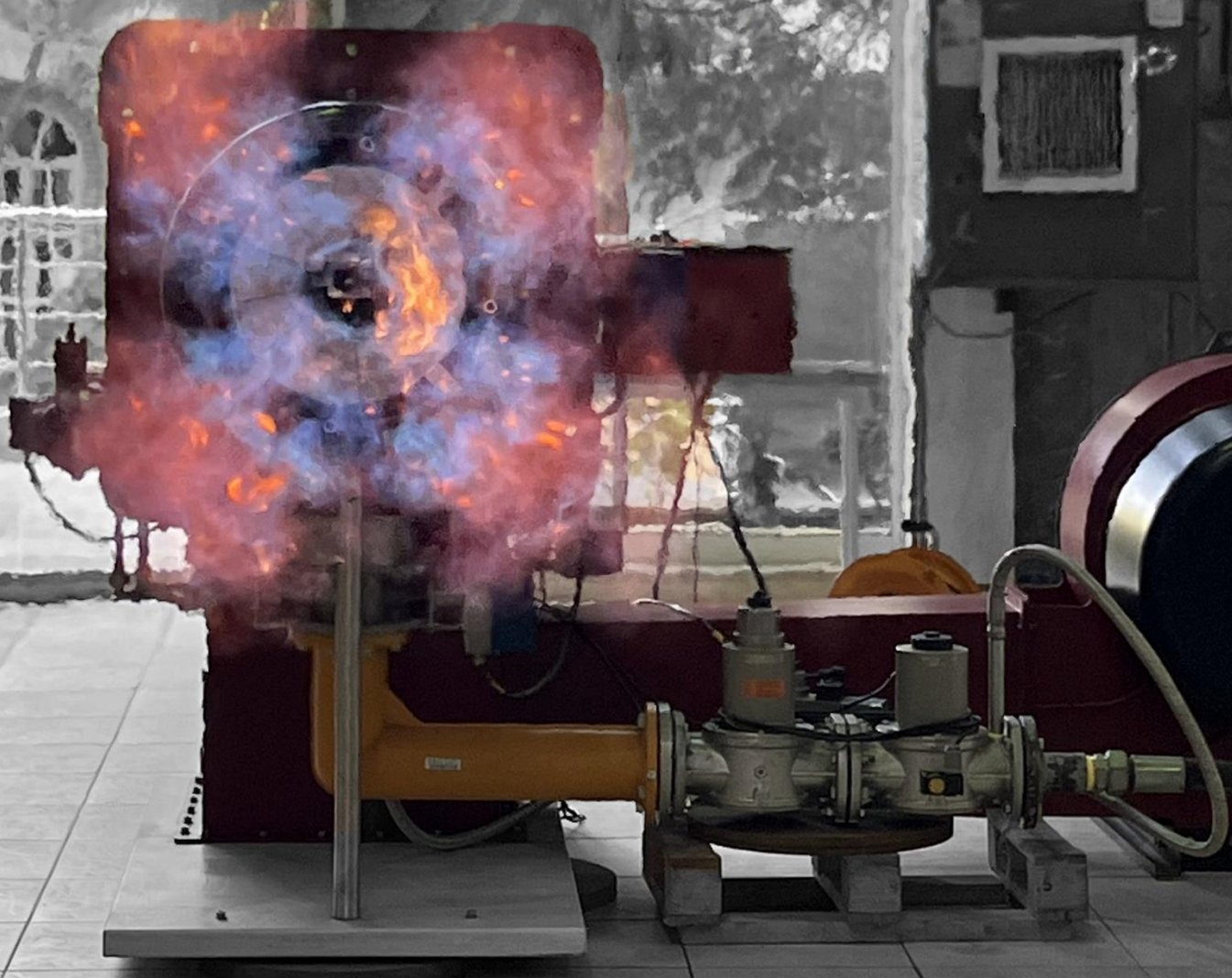

# Index

---

## Staging Mono Block Burners (100-6200 kW)

---



Staging mono block burners  
 RGB series capacity diagram  
 RGB series dimension  
 RGB series technical  
 RLGB series capacity diagram RLGB  
 series dimension  
 RLGB series technical  
 Gas train  
 Emission

Page 25-50

---

## Mechanical Staging Mono Block Burners (300-6200 kW)

---



Mechanical mono block burners  
 Burner management diagram  
 RGB-MS series diagram  
 RGB-MS series dimension  
 RGB-MS series technical  
 RLGB-MS series capacity diagram  
 RLGB-MS series dimension  
 RLGB-MS series technical  
 Gas train  
 Emission

Page 51-72

---

## Mechanical Modular Mono Block Burners (300-6200 kW)

---



Mechanical mono block burners  
 Burner management diagram  
 RGB-MC series diagram  
 RGB-MC series dimension  
 RGB-MC series technical  
 RLGB-MC series capacity diagram  
 RLGB-MC series dimension  
 RLGB-MC series technical  
 Gas train  
 Emission

Page 73-94



---

## Electronic Modular Mono Block Burners (160-25000 kW)

---



Electronic mono block burners  
 Burner management diagram  
 RGB-M series capacity diagram  
 RGB-M series dimension  
 RGB-M series technical  
 RLGB-M series capacity diagram  
 RLGB-M series dimension  
 RLGB-M series technical  
 RLGB-M/M series capacity diagram  
 RLGB-M/M series dimension  
 RLGB-M/M series technical  
 Gas train  
 Emission

Page 95-142

---

## Premixed Burners (100-4000 kW)

---



Premixed burners  
 Burner management diagram  
 Post Mixed capacity diagram  
 Post Mixed dimension  
 Premixed capacity diagram  
 Premixed dimension  
 Gas train

Page 143-160

---

## Dual Block Burners (1000-32000 kW)

---



Dual block burners  
 Burner management system  
 RGB-M-...-DB series capacity diagram  
 RGB-M-...-DB series dimension  
 RLGB-M/M-...-DB series capacity  
 diagram  
 RLGB-M/M-...-DB series dimension  
 Gas train

Page 161-178

---

## Fire Heater Burner

---



Fire heater burner

Page 179-182

---

## Water Tube Burners

---



Water tube burner

Page 183-198

---

## System Component

---



Gas train

Page 199-202



Burner Ventilation system

Page 203-208



Burner Ventilation Motor Starter

Page 209-218

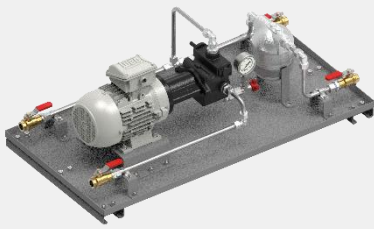

Oil station

Page 219-228

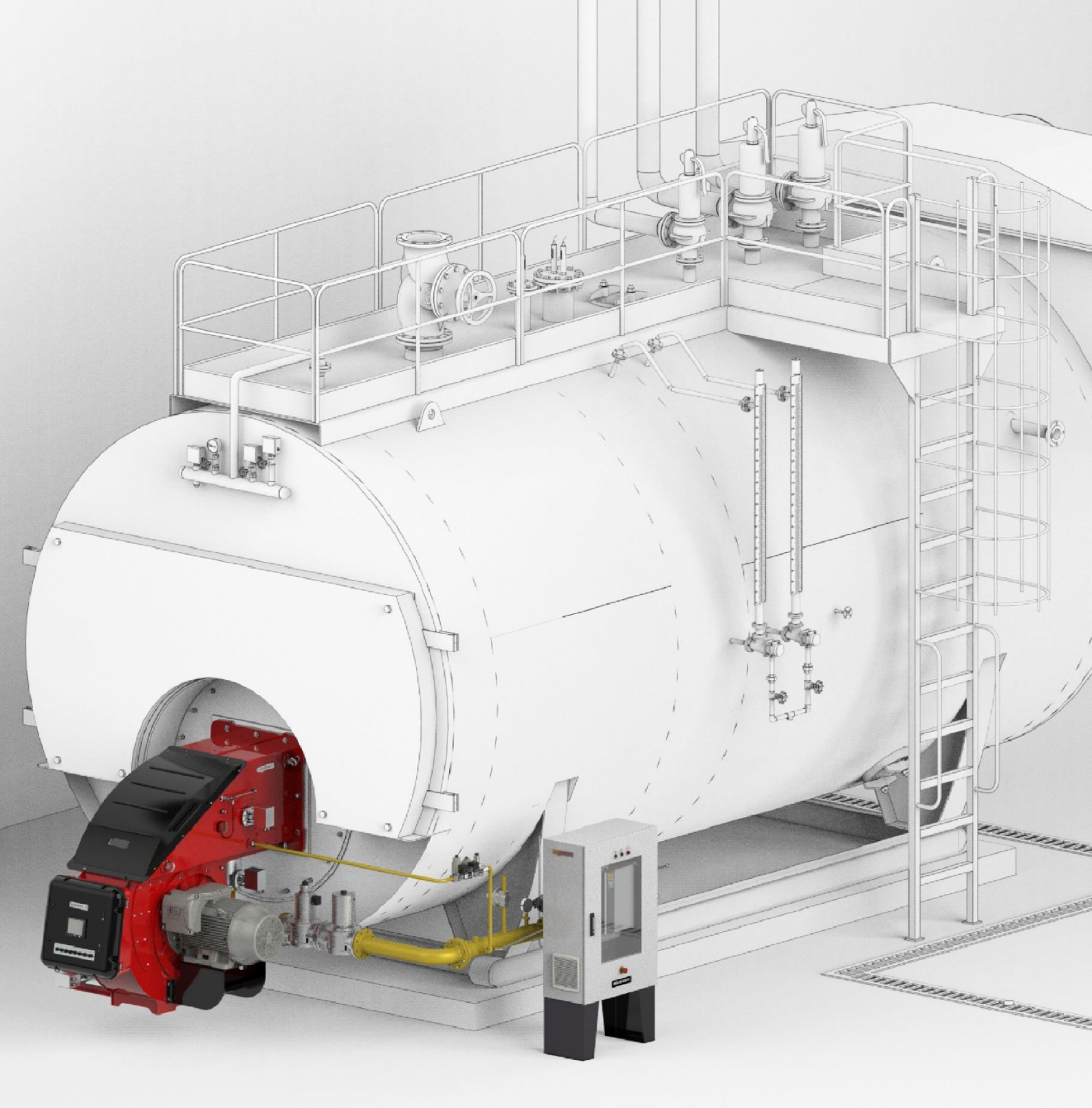

- raadman -

- The unique design of compact burners for convenient and optimum utilizations





# Staging Mono Block Burners

Heat Rated Output: 100-6200 kW



- SMILE INTO THE FUTURE -

[www.raadmanburner.com](http://www.raadmanburner.com)



# raadman staging mono block burner

raadman staging burners cover a firing range from 160 kW to 6200 kW in II or III stage natural gas and light fuel oil. These burners, equipped with high-quality electro-mechanical accessories with easy installation, commissioning and maintenance are economically designed for domestic or industrial applications such as three pass hot water boilers, steam boilers, hot air generator, etc.

Two or three stage burners, following the temperature/steam load requested by the system, lead to operation at full (or medium) and reduced output, with consequent reduction in turning the burner on and off, that gives better performances to the boiler. Since the burner's air damper is independently controlled by an electric servomotor, during stand-by, the air entrances are getting completely closed and prevents heat loss due to the flue natural draught.

One of the most highlighted privileges of raadman staging burners is the lack of mechanical link between gas butterfly valve and air damper. In other words, air damper is controlled by two or three independent stepping actuators. At the same time, gas (or light oil) is controlled by two or three parallel solenoid valves that leads to a precise control and adjustment on each burner stage. This will cooperate in a superior and complete combustion.

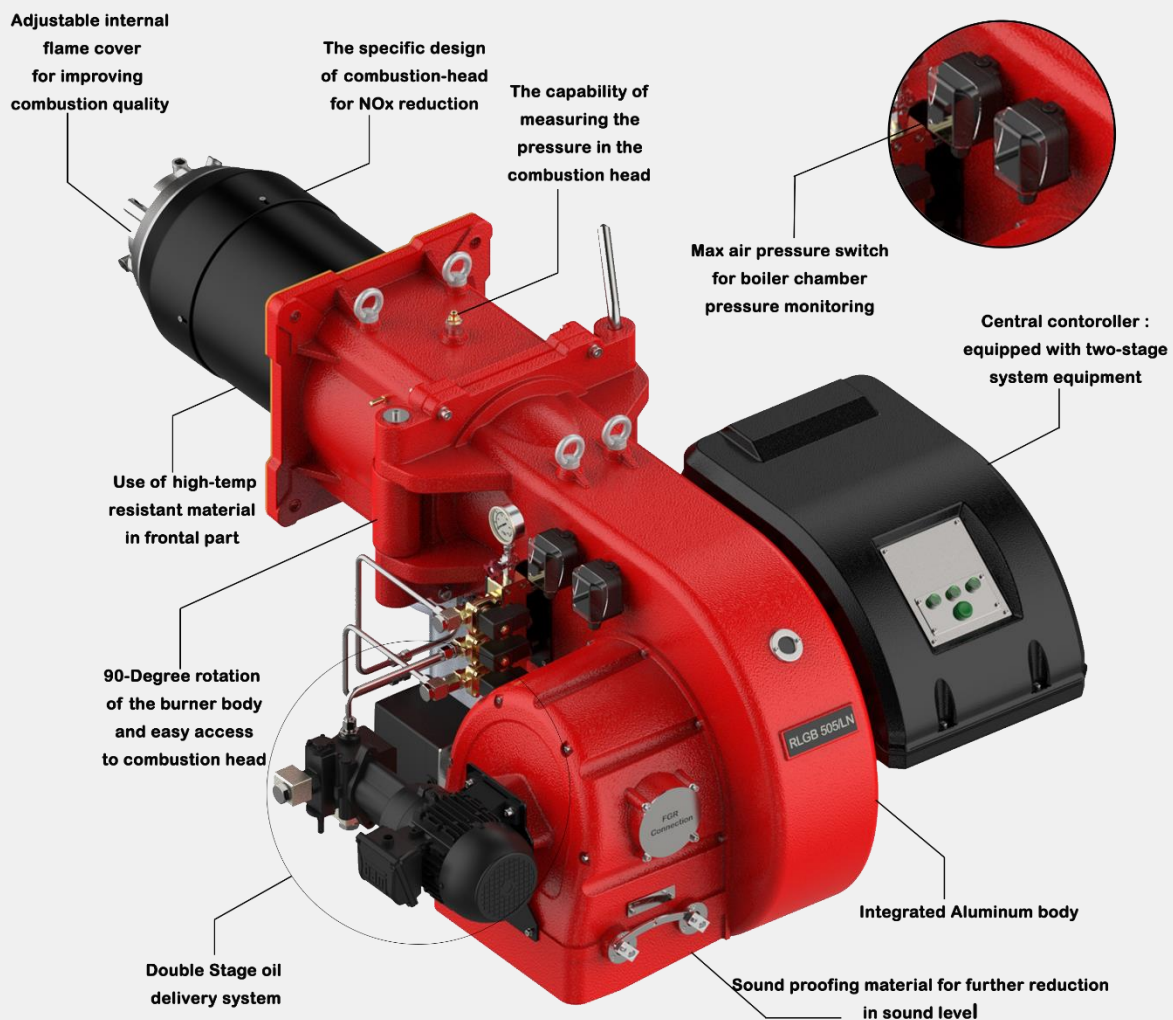



# raadman RGB series burner

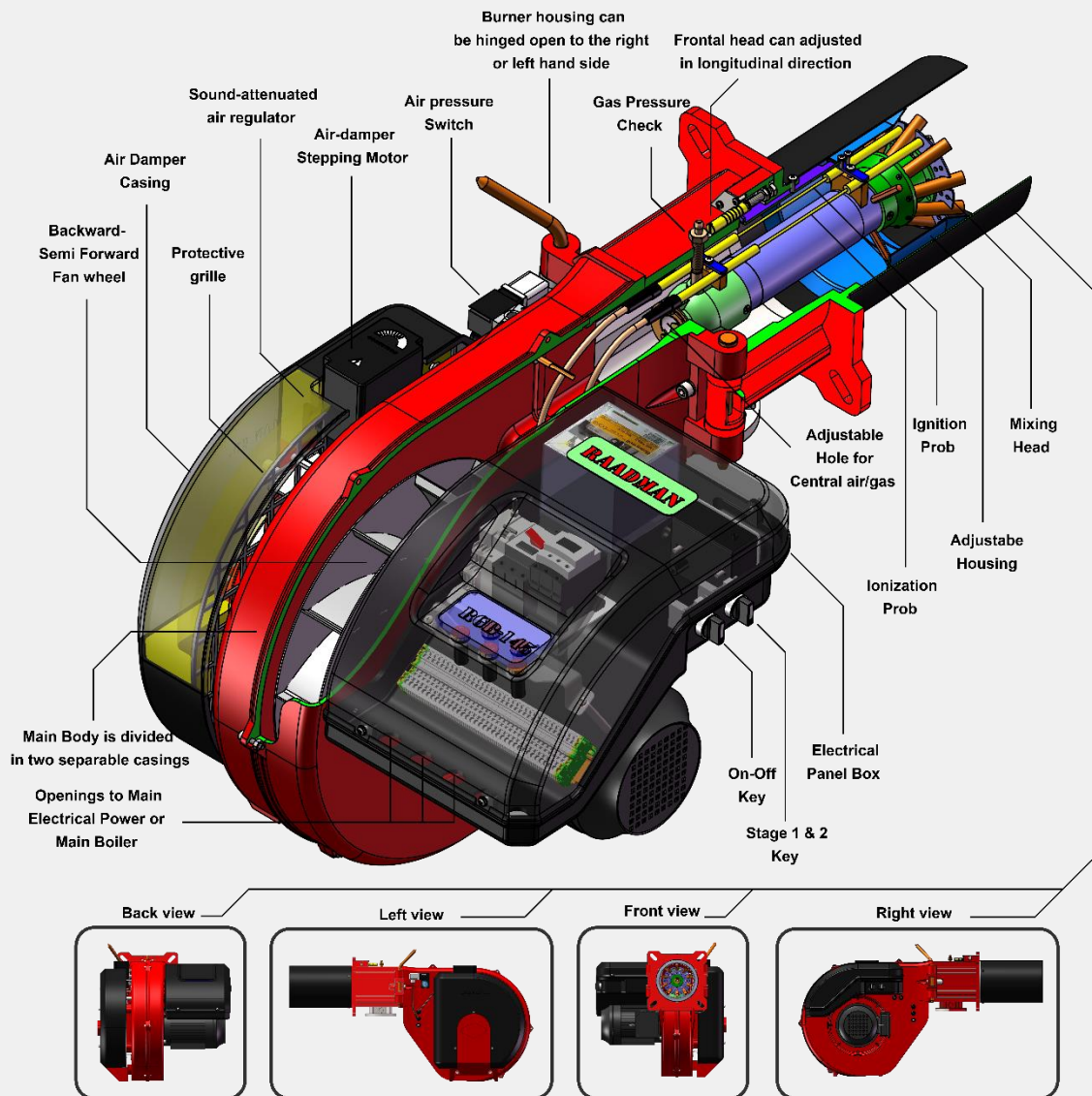

# Burner selection: capacity and working diagram

## Staging Gas Burner

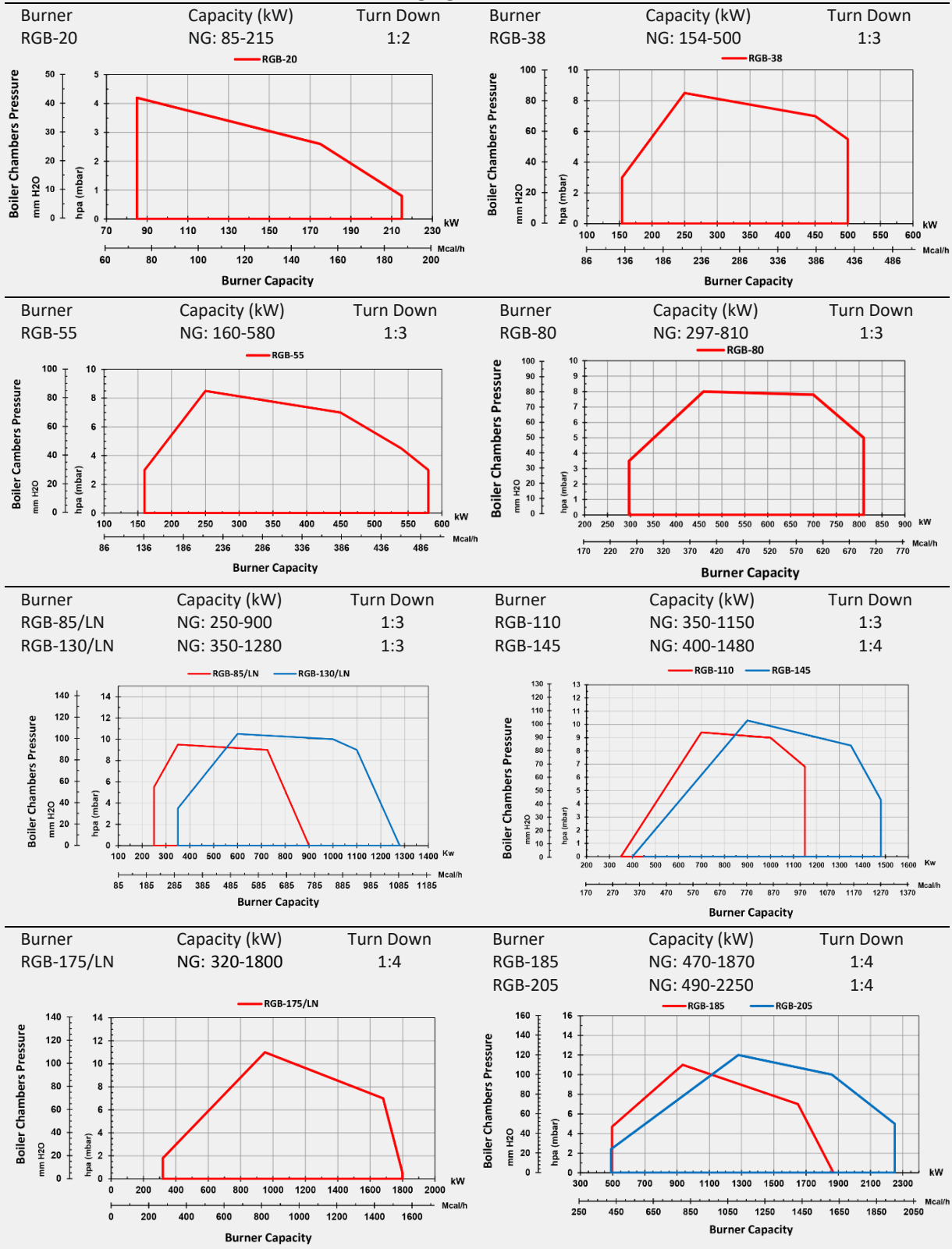





Burner	Capacity (kW)	Turn Down
RGB-255/LN	NG: 580-2400	1:4

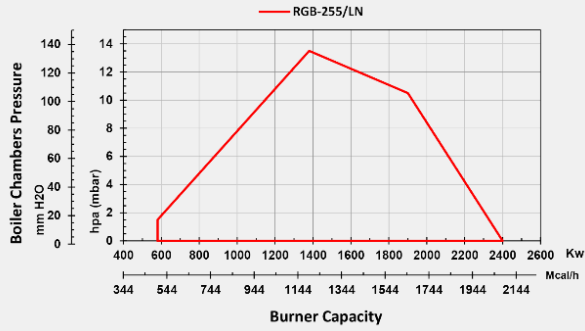

Burner	Capacity (kW)	Turn Down
RGB-305	NG: 600-3000	1:5
RGB-385	NG: 650-3800	1:5

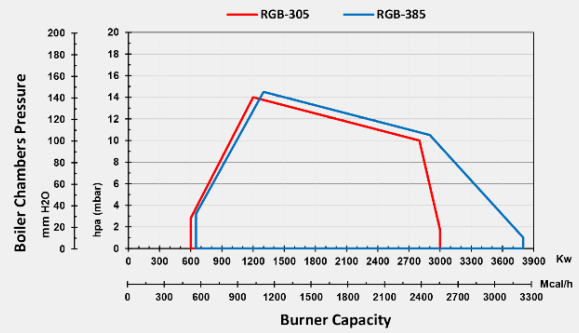

Burner	Capacity (kW)	Turn Down
RGB-405/LN	NG: 680-4100	1:6
RGB-505/LN	NG: 700-5100	1:7

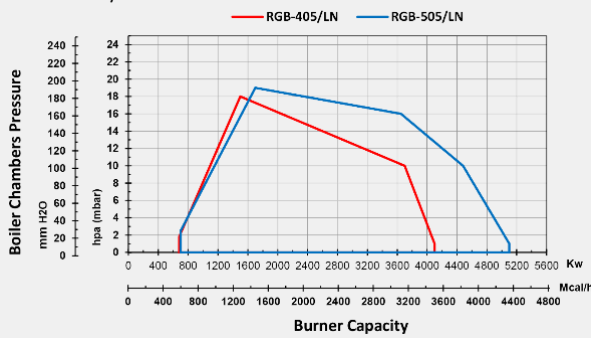

Burner	Capacity (kW)	Turn Down
RGB-605	NG: 850-6200	1:7

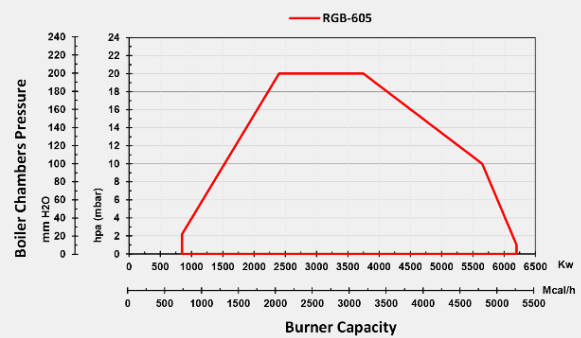

About the working diagram: Working diagram for gas burner is certified in accordance with BS-EN 676. The firing rate diagram has been obtained considering ambient temperature of 20°C and atmospheric pressure of 1013 mbar (Sea level condition). For installation at higher altitudes, a reduction in capacity of 1% per 100 m above sea level should be taken into account.





# General dimension: RGB series

## RGB-20

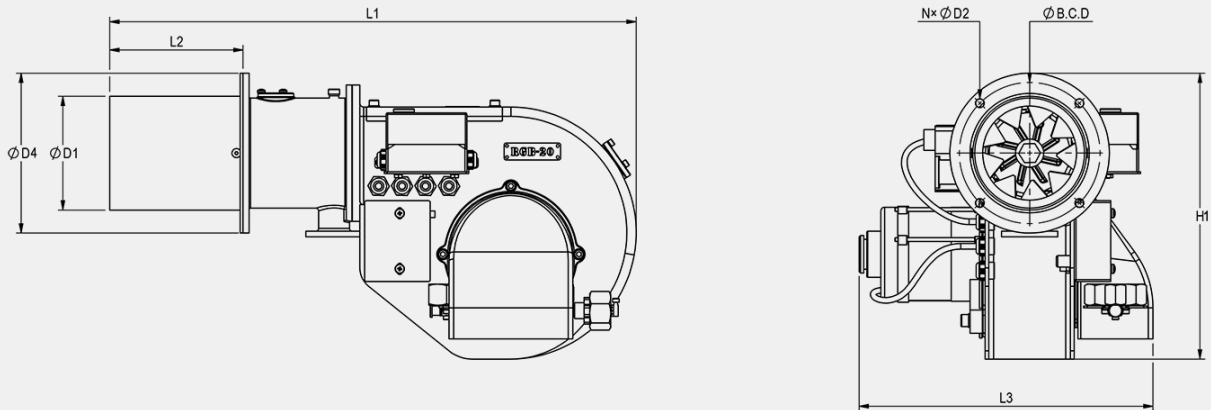

Burner Type	L <sub>1</sub>	L <sub>2</sub>	L <sub>3</sub>	H	D <sub>1</sub>	D <sub>2</sub>	D <sub>3</sub>	N	B.C. D
RGB-20	561	142	313	304	124	9	170	4	150

## RGB-38, RGB-55

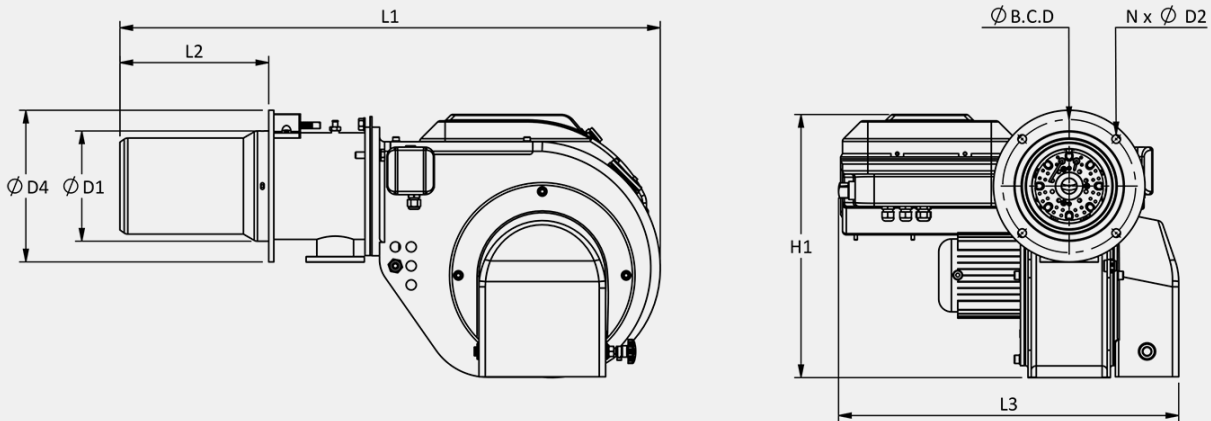

Burner Type	L <sub>1</sub>	L <sub>2</sub>	L <sub>3</sub>	H	D <sub>1</sub>	D <sub>2</sub>	D <sub>3</sub>	N	B.C. D
RGB-38	851	235	538	427	179	13.5	240	4	210
RGB-55	851	235	568	427	179	13.5	204	4	210

## RGB-80

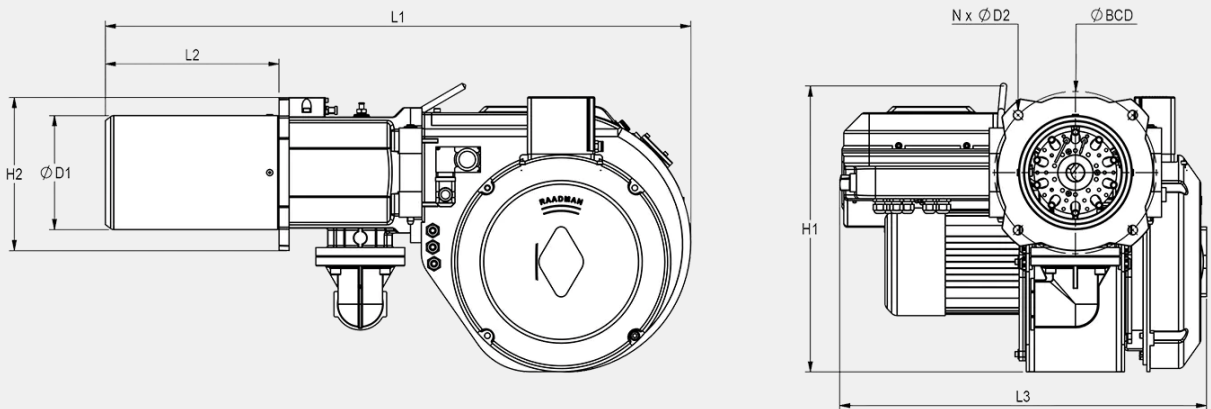

Burner Type	L <sub>1</sub>	L <sub>2</sub>	L <sub>3</sub>	H <sub>1</sub>	H <sub>2</sub>	D <sub>1</sub>	D <sub>2</sub>	N	B.C. D
RGB-80	921	273.5	574	432	240.5	183	15	4	255

### RGB-85/LN, RGB-130/LN

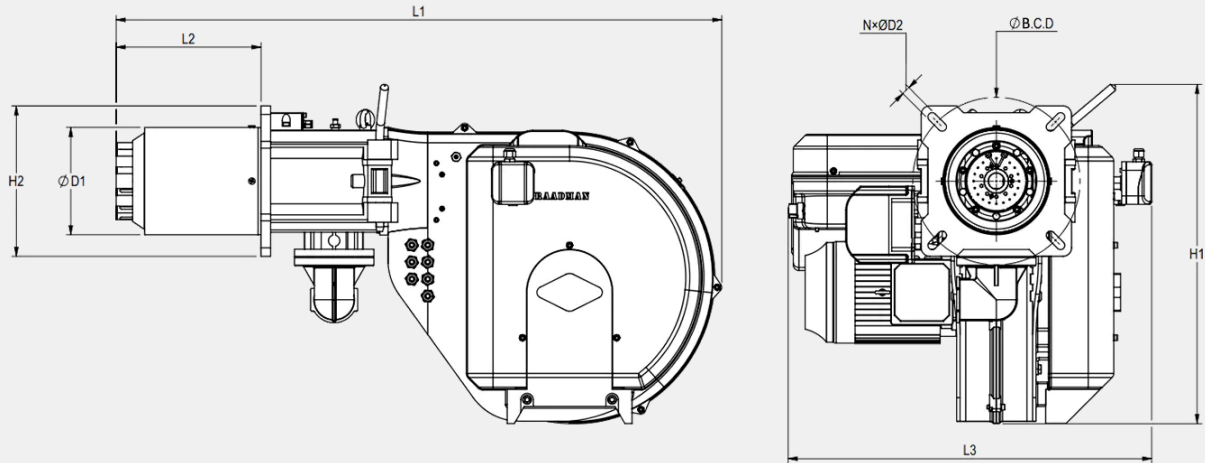

Burner Type	L <sub>1</sub>	L <sub>2</sub>	L <sub>3</sub>	H <sub>1</sub>	H <sub>2</sub>	D <sub>1</sub>	D <sub>2</sub>	N	B.C. D
RGB-85/LN	1068	255	582	600	265	190	15	4	295
RGB-130/LN	1072	260	582	600	265	190	15	4	295

### RGB-110, RGB-145

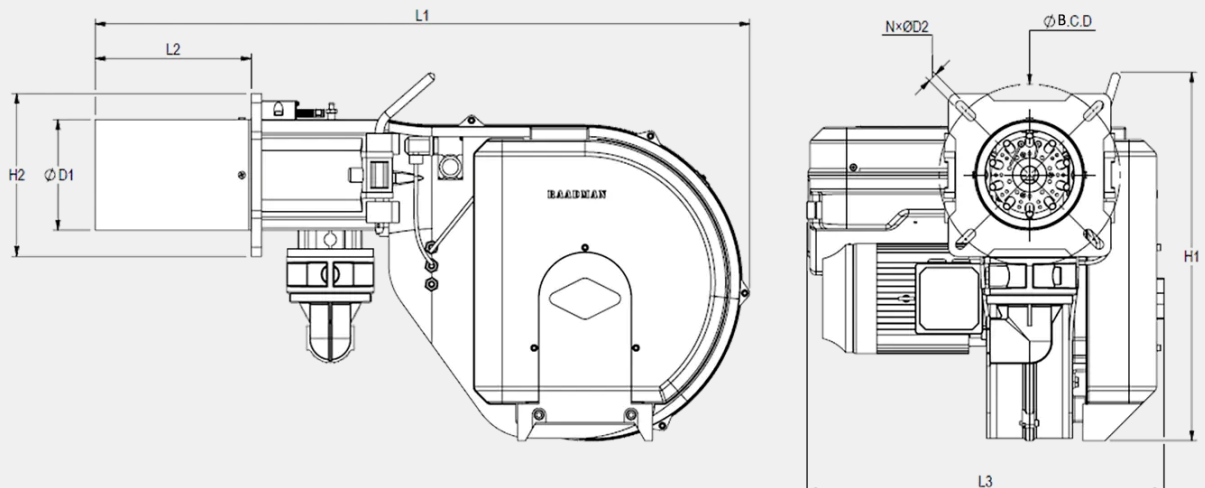

Burner Type	L <sub>1</sub>	L <sub>2</sub>	L <sub>3</sub>	H <sub>1</sub>	H <sub>2</sub>	D <sub>1</sub>	D <sub>2</sub>	N	B.C. D
RGB-110	1066	254	582	600	265	184	15	4	295
RGB-145	1097	285	582	600	265	194	15	4	295

### RGB-175/LN

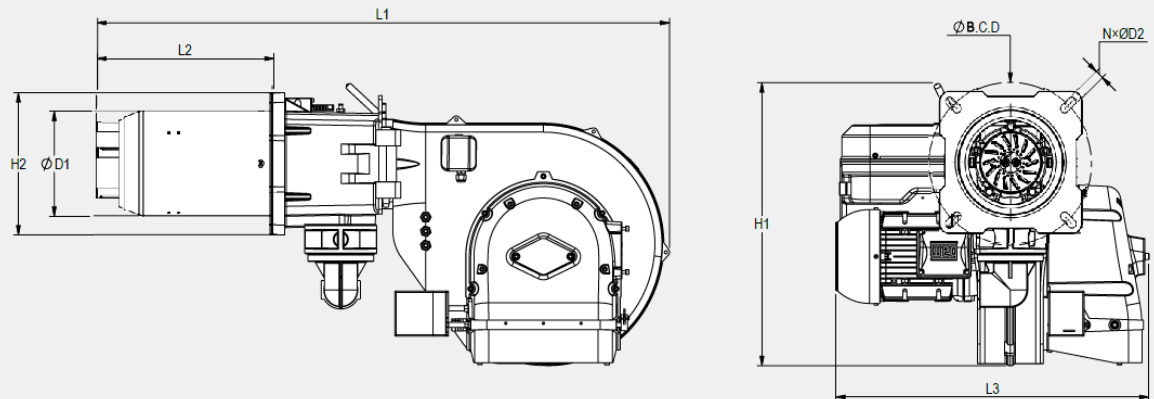

Burner Type	L <sub>1</sub>	L <sub>2</sub>	L <sub>3</sub>	H <sub>1</sub>	H <sub>2</sub>	D <sub>1</sub>	D <sub>2</sub>	N	B.C. D
RGB-175/LN	1213	373	666	600	302	223	15	4	345

### RGB-185, RGB-205

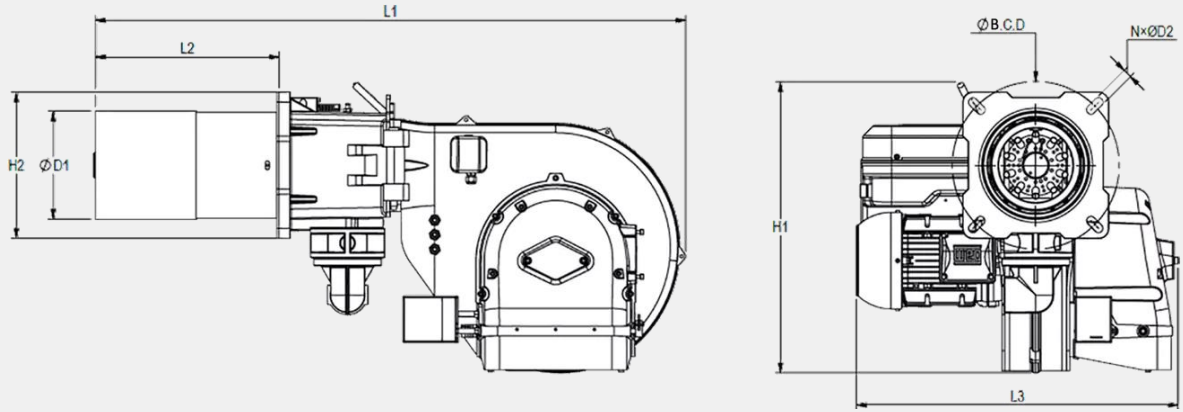

Burner Type	L <sub>1</sub>	L <sub>2</sub>	L <sub>3</sub>	H <sub>1</sub>	H <sub>2</sub>	D <sub>1</sub>	D <sub>2</sub>	N	B.C. D
RGB-185	1222	380	666	600	302	223	18	4	345
RGB-205	1222	380	666	600	302	223	18	4	345

### RGB-255/LN

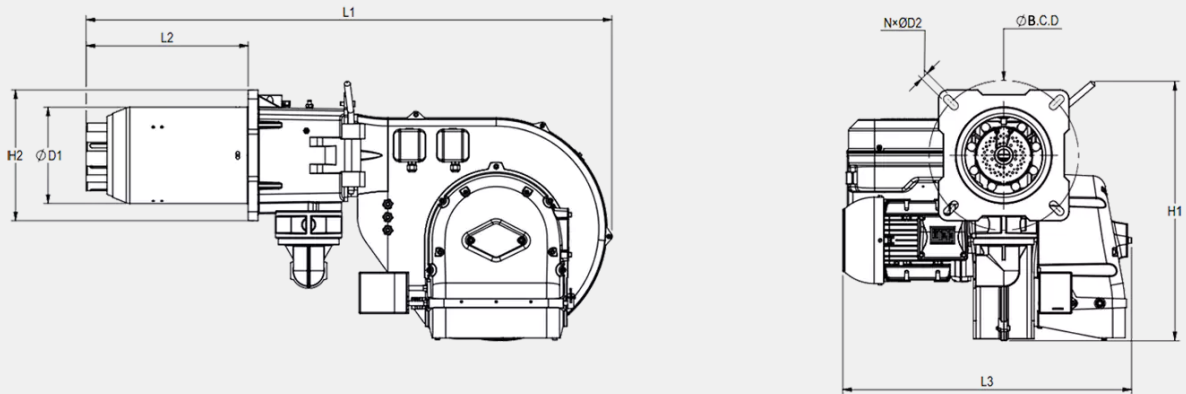

Burner Type	L <sub>1</sub>	L <sub>2</sub>	L <sub>3</sub>	H <sub>1</sub>	H <sub>2</sub>	D <sub>1</sub>	D <sub>2</sub>	N	B.C. D
RGB-255/LN	1213	374	666	600	302	222	18	4	345

### RGB-305, RGB-385

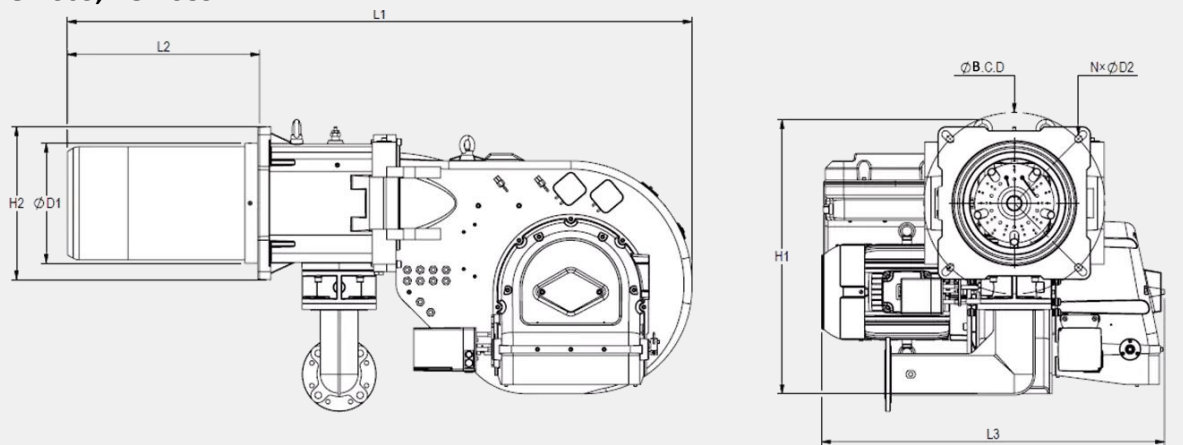

Burner Type	L <sub>1</sub>	L <sub>2</sub>	L <sub>3</sub>	H <sub>1</sub>	H <sub>2</sub>	D <sub>1</sub>	D <sub>2</sub>	N	B.C. D
RGB-385	1689	520	927	741	413	325	20	4	490
RGB-305	1689	520	927	741	413	325	20	4	490

### RGB-405/LN, RGB-505/LN

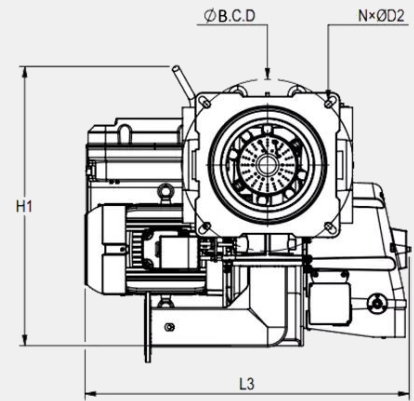
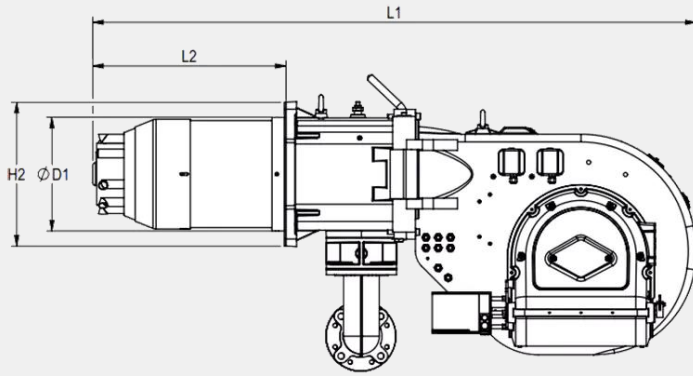

Burner Type	L <sub>1</sub>	L <sub>2</sub>	L <sub>3</sub>	H <sub>1</sub>	H <sub>2</sub>	D <sub>1</sub>	D <sub>2</sub>	N	B.C. D
RGB-405/LN	1720	552	925	798	413	324	20	4	490
RGB-505/LN	1720	552	925	798	413	324	20	4	490

### RGB-605

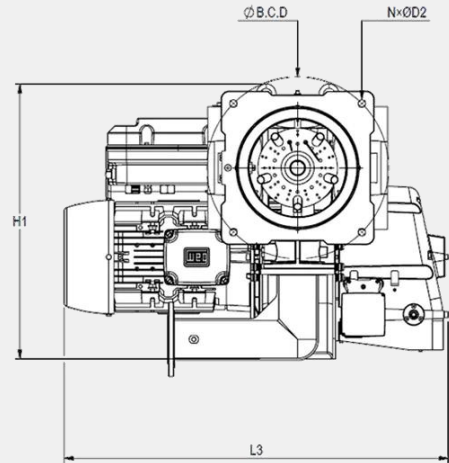
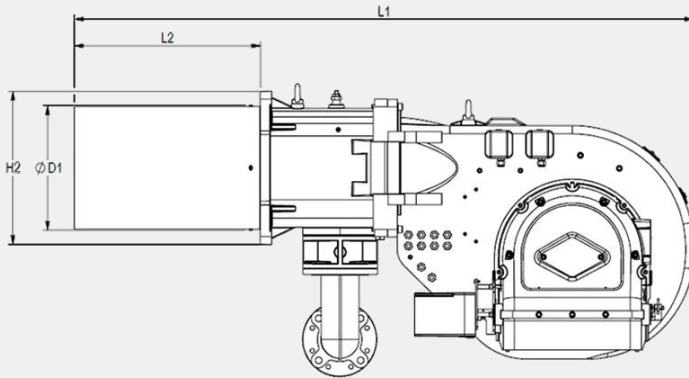

Burner Type	L <sub>1</sub>	L <sub>2</sub>	L <sub>3</sub>	H <sub>1</sub>	H <sub>2</sub>	D <sub>1</sub>	D <sub>2</sub>	N	B.C. D
RGB-605	1671	502	1036	741	413	338	20	4	490



Dual Block Burner





## Technical data: RGB series

RGB burners include ventilation system with AC motor, Ignition transformer, and electrodes, electrical panel with power contactors, fuses, relays, central controller, air pressure switches, soundproofing material, Lamp signals for operational supervision, etc.

Burner	Motor (kW/PH/V/HZ/rpm)	Controller	Actuator (N.m)
RGB-20	0.3 /1 /220 /50 /2700	Shokouh	--
RGB-38	0.45 /1 /220 /50 /2700	Shokouh	--
RGB-55	0.75 /3 /380-400 /50 /2840	Siemens/ Shokouh	2.5 or 3
RGB-80	1.1 /3 /380-400 /50 /2850	Siemens/ Shokouh	2.5 or 3
RGB-85/LN	1.5 /3 /380-400 /50 /2840	Siemens/ Shokouh	2.5 or 3
RGB-110	1.5 /3 /380-400 /50 /2840	Siemens/ Shokouh	2.5 or 3
RGB-130/LN	2.2 /3 /380-400 /50 /2840	Siemens/ Shokouh	2.5 or 3
RGB-145	2.2 /3 /380-400 /50 /2840	Siemens/ Shokouh	2.5 or 3
RGB-175/LN	4 /3 /380-400 /50 /2840	Siemens/ Shokouh	3
RGB-185	5.5 /3 /380-400 /50 /2840	Siemens/ Shokouh	3
RGB-205	5.5 /3 /380-400 /50 /2840	Siemens/ Shokouh	3
RGB-255/LN	5.5 /3 /380-400 /50 /2840	Siemens/ Shokouh	3
RGB-305	7.5 /3 /380-400 /50 /2900	Siemens/ Shokouh	3
RGB-385	7.5 /3 /380-400 /50 /2900	Siemens/ Shokouh	3
RGB-405/LN	11 /3 /380-400 /50 /2900	Siemens	10
RGB-505/LN	11 /3 /380-400 /50 /2900	Siemens	10
RGB-605	15 /3 /380-400 /50 /2900	Siemens	10

# raadman RLGB series burner

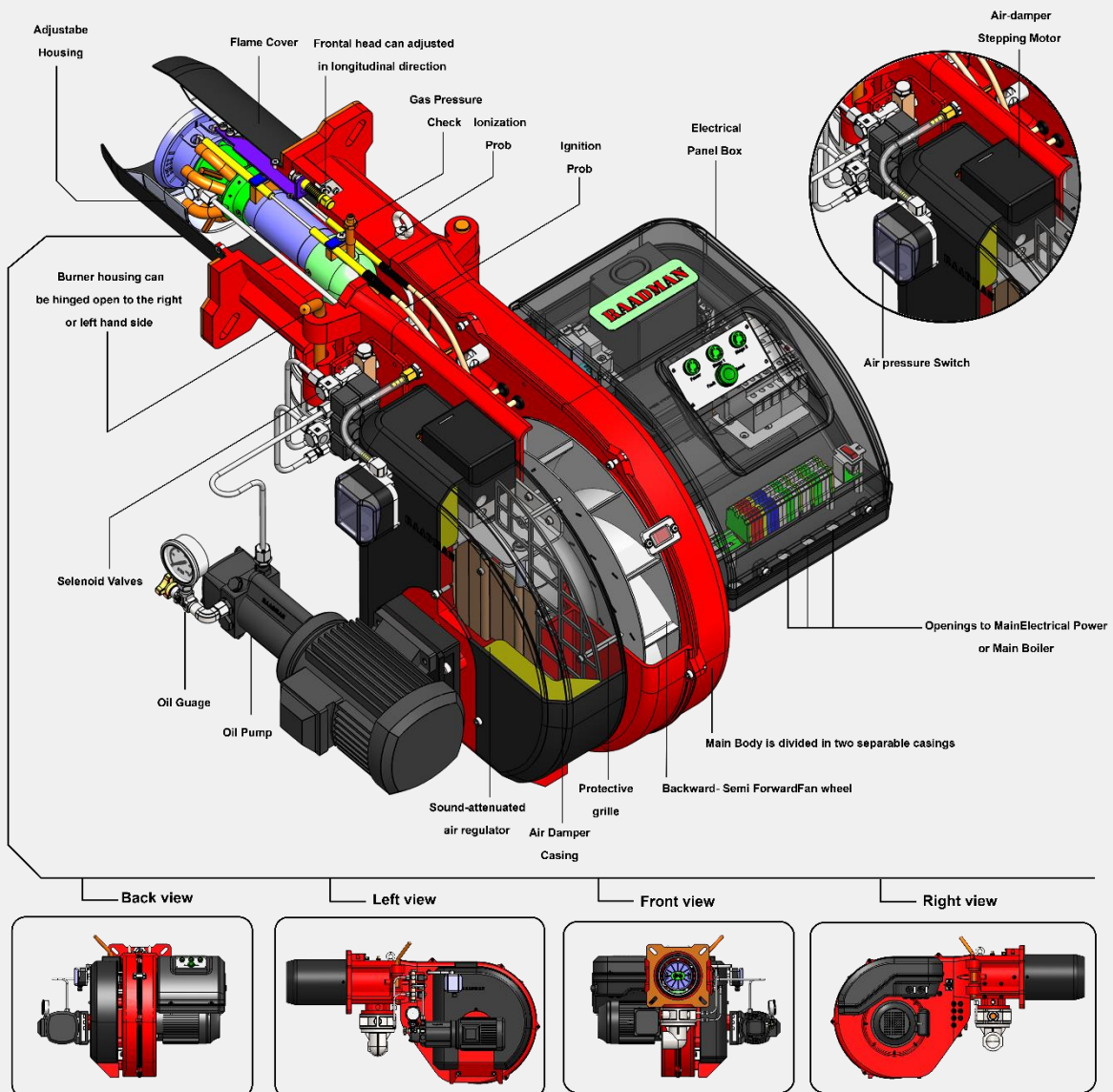



# Burner selection: capacity and working diagram

## Staging Dual-Fuel Burner

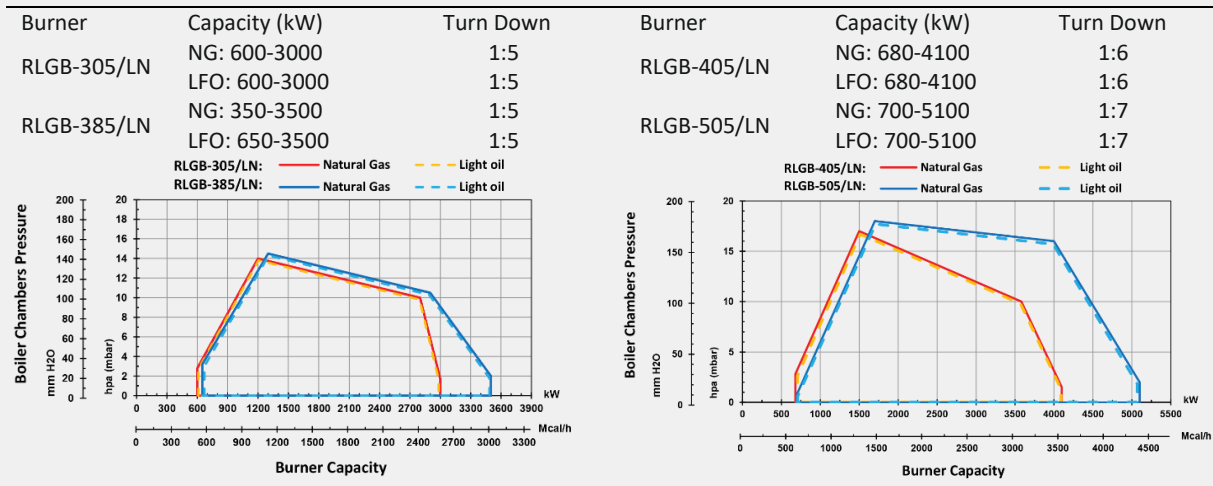
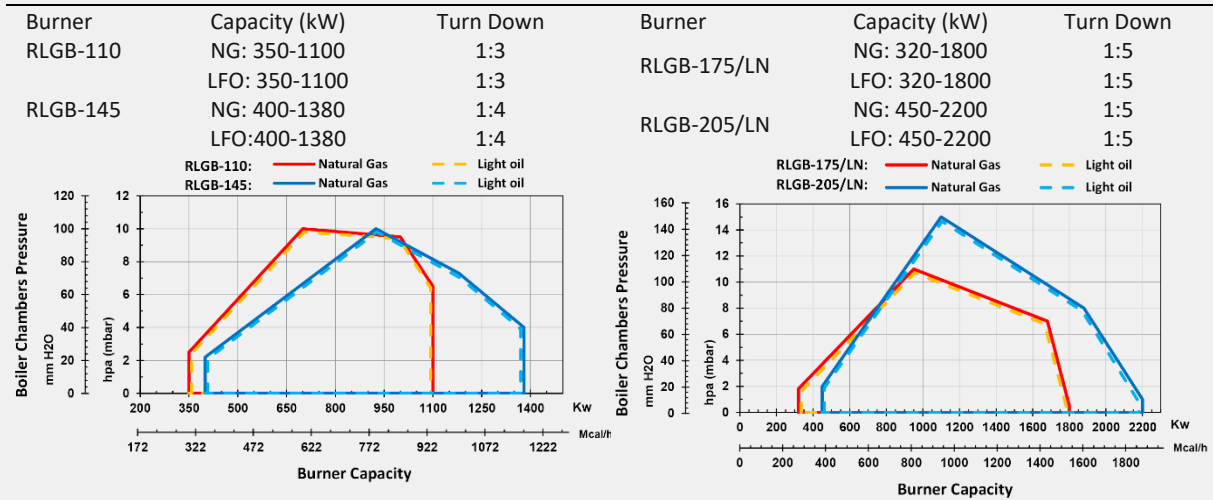
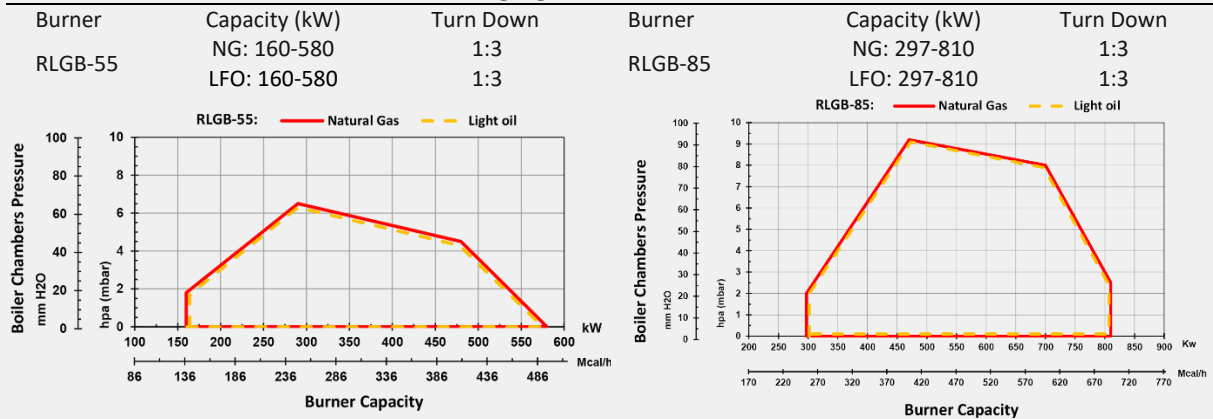



Burner	Capacity (kW)	Turn Down	Burner	Capacity (kW)	Turn Down
RLGB-605/LN	NG: 1000-6100	1:6	RLGB-255/LN	NG: 580-2400	1:4
	LFO: 1000-6100	1:6		LFO: 580-2400	1:4

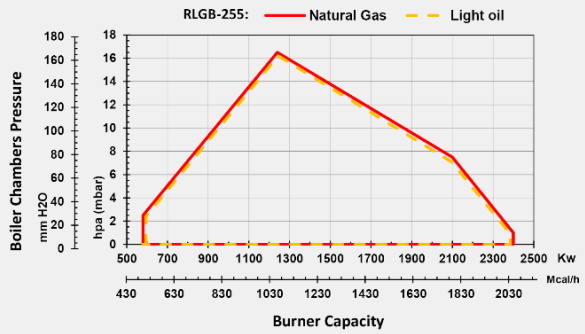
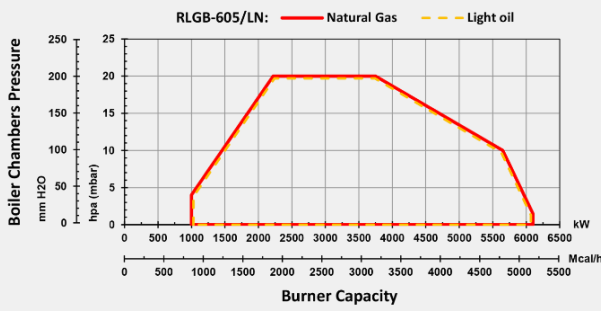

Working diagrams for gas and light fuel oil burner are certified in accordance with BS-EN 676 and BS-EN 267. The firing rate diagram has been obtained considering the ambient temperature of 20°C and atmospheric pressure of 1013 mbar (Sea level condition).



# General dimension: RLGB series

## RLGB-55

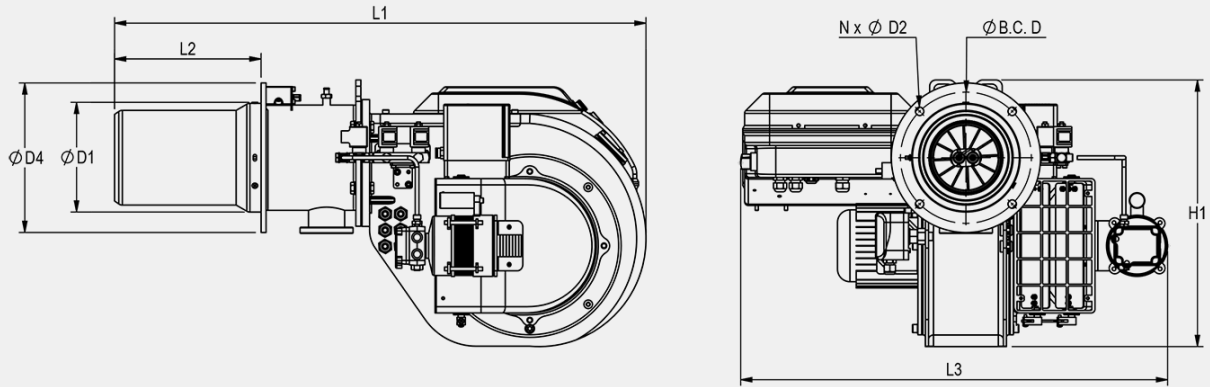

Burner Type	L <sub>1</sub>	L <sub>2</sub>	L <sub>3</sub>	H	D <sub>1</sub>	D <sub>2</sub>	D <sub>3</sub>	N	B.C. D
RLGB-55	853	235	685	427	178	13.5	240	4	210

## RLGB-85

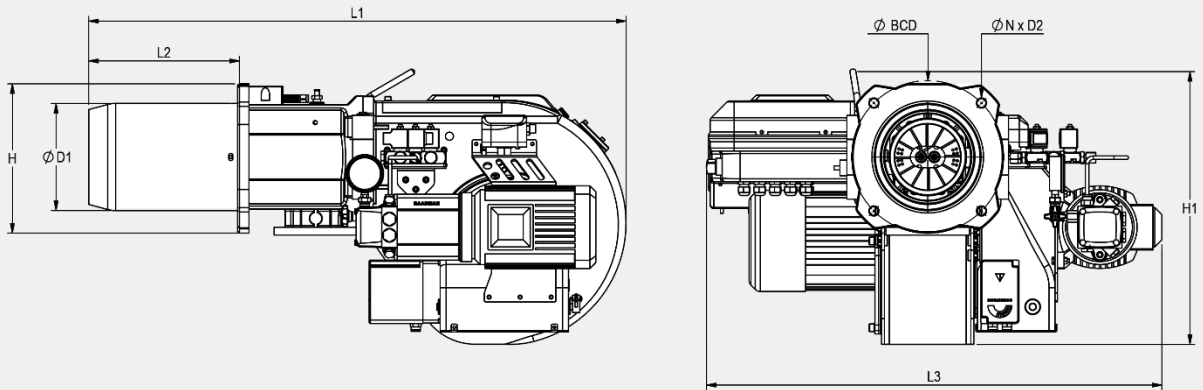

Burner Type	L <sub>1</sub>	L <sub>2</sub>	L <sub>3</sub>	H <sub>1</sub>	H <sub>2</sub>	D <sub>1</sub>	D <sub>2</sub>	N	B.C. D
RLGB-85	902	253	760	461	250	182	15	4	255

## RLGB-110, RLGB-145

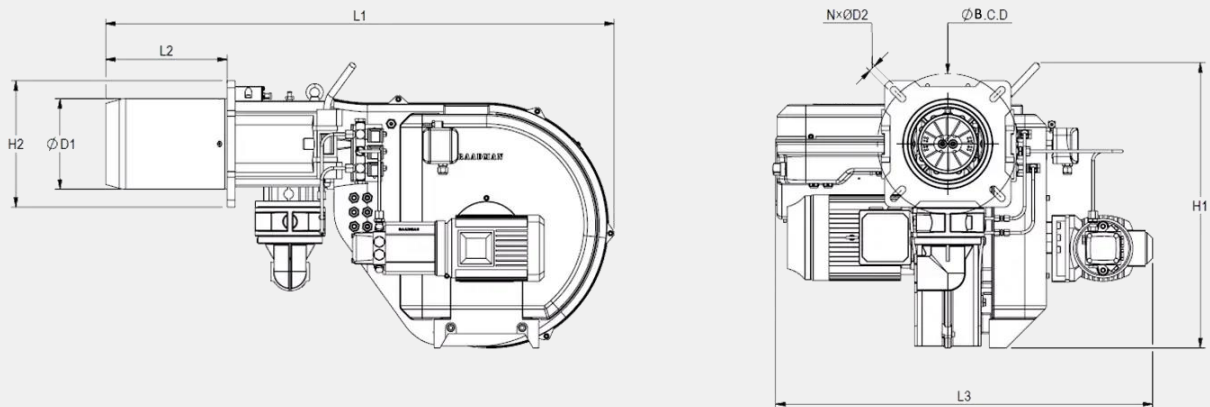

Burner Type	L <sub>1</sub>	L <sub>2</sub>	L <sub>3</sub>	H <sub>1</sub>	H <sub>2</sub>	D <sub>1</sub>	D <sub>2</sub>	N	B.C. D
RLGB-110	1068	255	797	600	265	180	15	4	295
RLGB-145	1068	255	797	600	265	190	15	4	295

### RLGB-175/LN, RLGB-205/LN

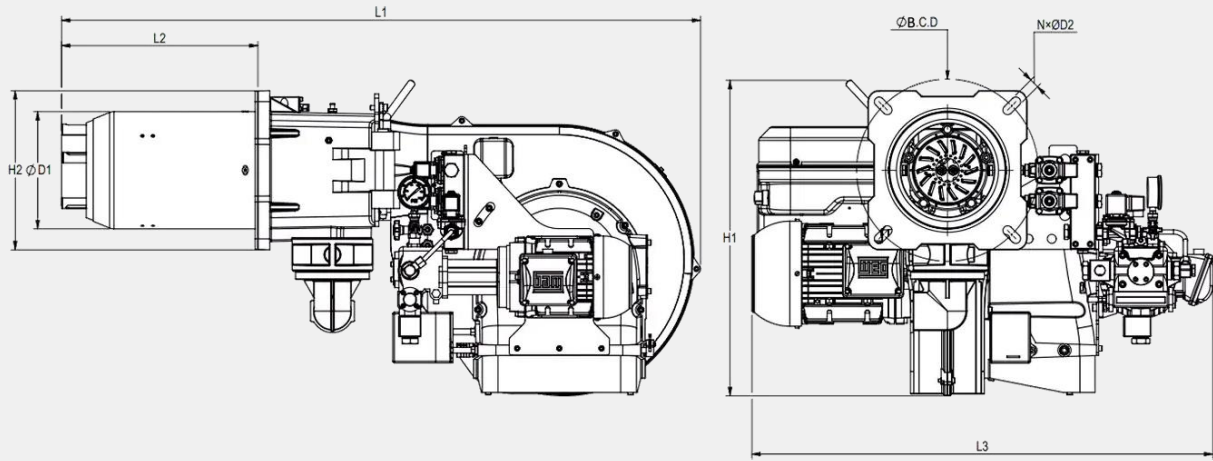

Burner Type	L <sub>1</sub>	L <sub>2</sub>	L <sub>3</sub>	H <sub>1</sub>	H <sub>2</sub>	D <sub>1</sub>	D <sub>2</sub>	N	B.C. D
RLGB-175/LN	1213	373	875	600	302	223	15	4	345
RLGB-205/LN	1213	373	875	600	302	223	15	4	345

### RLGB-255

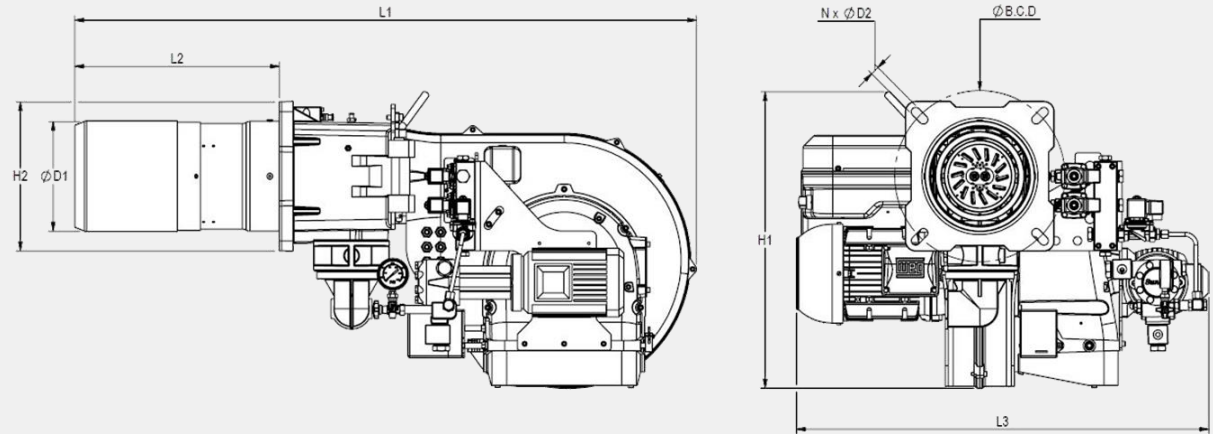

Burner Type	L <sub>1</sub>	L <sub>2</sub>	L <sub>3</sub>	H <sub>1</sub>	H <sub>2</sub>	D <sub>1</sub>	D <sub>2</sub>	N	B.C. D
RLGB-255	1260	419	833	600	302	224	18	4	345





**RLGB-305/LN, RLGB-385/LN, RLGB-405/LN, RLGB-505/LN, RLGB-605/LN**

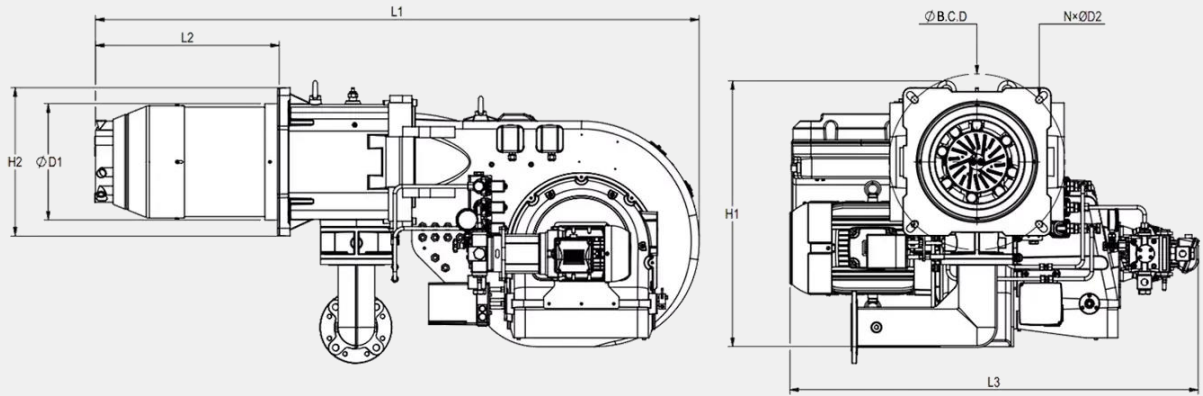

Burner Type	L <sub>1</sub>	L <sub>2</sub>	L <sub>3</sub>	H <sub>1</sub>	H <sub>2</sub>	D <sub>1</sub>	D <sub>2</sub>	N	B.C. D
RLGB-305/LN	1681	514	1137	741	413	328	20	4	490
RLGB-385/LN	1681	514	1137	741	413	328	20	4	490
RLGB-405/LN	1682	514	1200	741	413	328	20	4	490
RLGB-505/LN	1682	514	1137	741	413	328	20	4	490
RLGB-605/LN	1680	512	1246	741	413	340	20	4	490



Just for export

**RGB-M-385/FGR**  
 Capacity : 700 - 3750 kW  
 Fuel : Gas  
 Operate : Modular  
 NOx Class : B (Acc. To EN-616)

Just for export

**RGB-M-235/LN-FGR**  
 Capacity : 150 - 2300 kW  
 Fuel : Gas  
 Operate : Modular  
 NOx Class : B (Acc. To EN-616)

Just for export

**RGB-M-145**  
 Capacity : 100 - 1400 kW  
 Fuel : Gas  
 Operate : Modular  
 NOx Class : B (Acc. To EN-616)

Just for export

**RGB-M-110**  
 Capacity : 100 - 1100 kW  
 Fuel : Gas  
 Operate : Modular  
 NOx Class : B (Acc. To EN-616)

Just for export

**RGB-M-100**  
 Capacity : 100 - 1000 kW  
 Fuel : Gas  
 Operate : Modular  
 NOx Class : B (Acc. To EN-616)

Just for export

**RGB-M-100**  
 Capacity : 100 - 1000 kW  
 Fuel : Gas  
 Operate : Modular  
 NOx Class : B (Acc. To EN-616)

Just for export

**RGB-M-100**  
 Capacity : 100 - 1000 kW  
 Fuel : Gas  
 Operate : Modular  
 NOx Class : B (Acc. To EN-616)





- raadman -

The elegance of technology

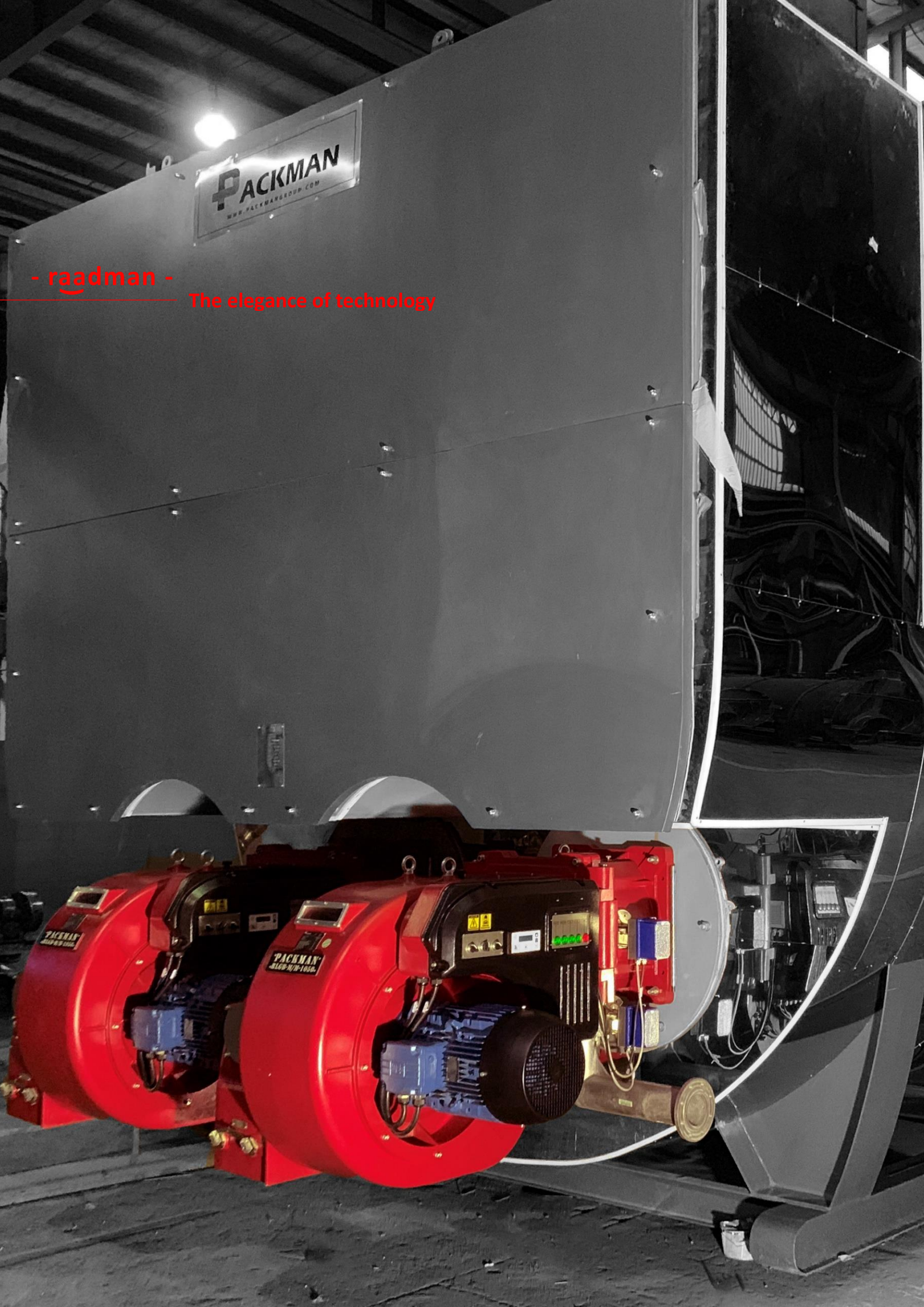

## Technical data: RLGB series

RLGB burners include: Ventilation system with AC motor, ignition transformer and electrodes, electrical panel with power contactors, fuses, relays, central controller, air pressure switches, Oil delivery solenoid valves and pressure gauges plus pump and AC motor with return and feed pipes, sound proofing material, Lamp signals for operational supervision, etc.

Burner	Motor (kW/PH/V/HZ/rpm)	Controller	Actuator (N.m)
RLGB-55	0.75/3/380-400/50/2850	Shokouh	2.5 or 3
RLGB-85	1.1 /3 /380-400 /50 /2840	Shokouh	2.5 or 3
RLGB-110	1.5 /3 /380-400 /50 /2840	Siemens/ Shokouh	2.5 or 3
RLGB-145	2.2 /3 /380-400 /50 /2840	Siemens/ Shokouh	2.5 or 3
RLGB-175/LN	4 /3 /380-400 /50 /2840	Siemens/ Shokouh	3
RLGB-205/LN	5.5 /3 /380-400 /50 /2840	Siemens/ Shokouh	3
RLGB-255	5.5 /3 /380-400 /50 /2840	Siemens/ Shokouh	3
RLGB-305/LN	7.5 /3 /380-400 /50 /2940	Siemens/ Shokouh	3
RLGB-385/LN	7.5 /3 /380-400 /50 /2940	Siemens/ Shokouh	3
RLGB-405/LN	11 /3 /380-400 /50 /2940	Siemens	10
RLGB-505/LN	11 /3 /380-400 /50 /2940	Siemens	10
RLGB-605/LN	15 /3 /380-400 /50 /2940	Siemens	10



# Gas train diagram

**GT1 (Pressure input < 360 mbar, separated items, Single Stage)**

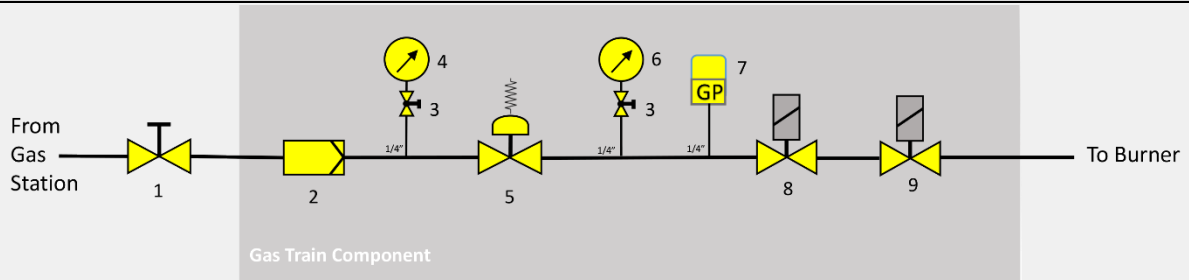

**GT2 (Pressure input < 360 mbar, separated items, Double Stage)**

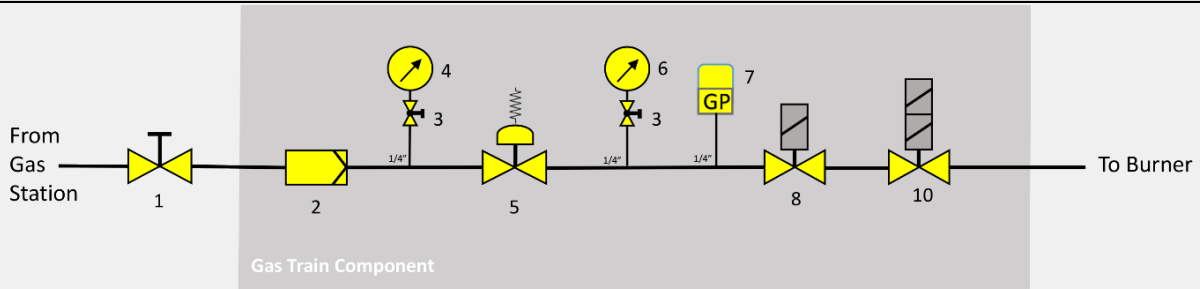

**GT3 (Pressure input < 360 mbar, separated items, Double Stage with valve proving system)**

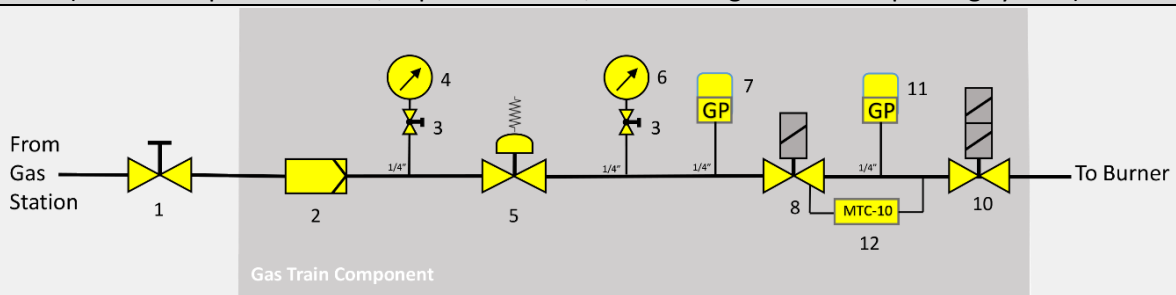

**GT4 (Pressure input < 360 mbar, multi block gas train items)**

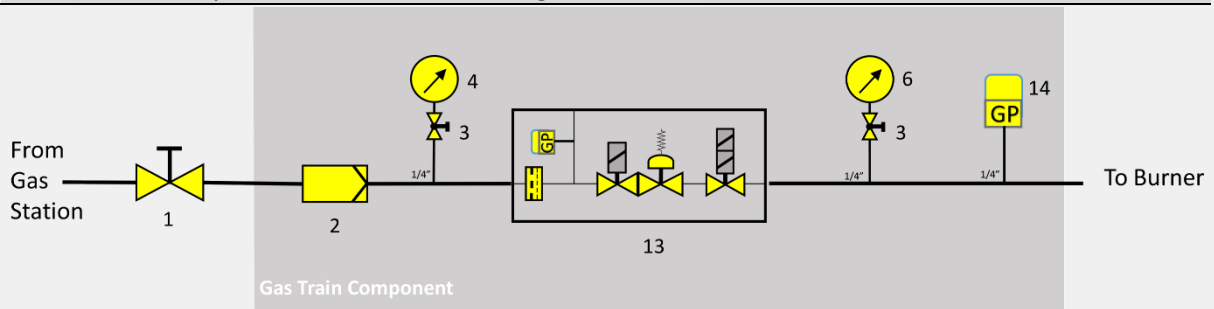

**GT5 (Pressure input < 360 mbar, multi block gas train items, with valve proving system)**

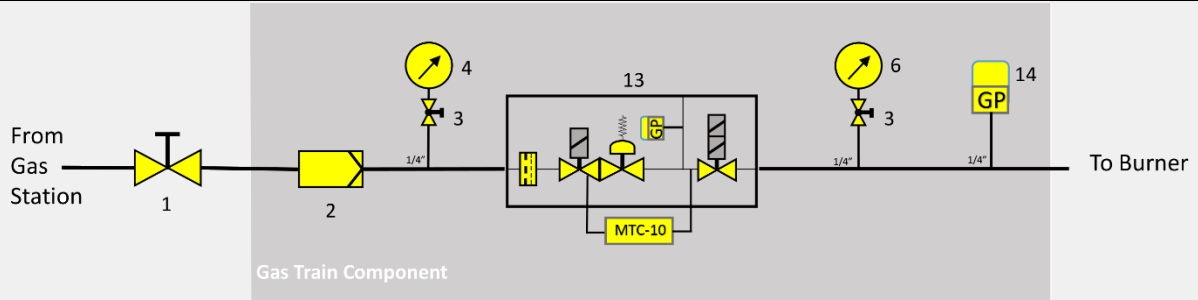

**GT6 (Pressure input < 360 mbar, separated gas train items, with valve proving system)**

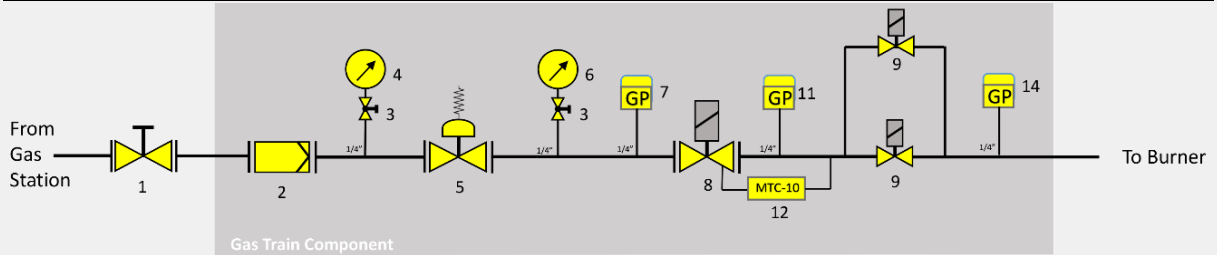

- |                      |                                      |                               |
|----------------------|--------------------------------------|-------------------------------|
| 1. Manual Valve      | 6. Pressure Gauge                    | 11. Leak Test Pressure Switch |
| 2. Gas Filter        | 7. Min. gas pressure switch          | 12. Valve Proving System      |
| 3. Push bottom valve | 8. Safety Solenoid Valve             | 13. Multi-Bloc Solenoid Valve |
| 4. Pressure Gauge    | 9. Stage Solenoid Valve              | 14. Max. gas pressure Switch  |
| 5. Regulator         | 10. Stage Solenoid Valve (Two Stage) |                               |

## Gas train sizing

RGB-Series...					
Burner	Gas model	Gas train size	Main solenoid valve size	$\Delta P B. V^*$	$\Delta P C.H^{**}$ (mbar)
RGB-20	GT1	Rp 1	Rp 1	-	0
RGB-38	GT1	Rp 1 ½	Rp 1 ½	-	5.6
RGB-55	GT2	Rp 1 ½	Rp 1 ½	-	7.2
	GT4	Rp 1 ½	Rp 1 ½		
RGB-80	GT2	Rp 1 ½	Rp 1 ½	-	10.3
	GT4	Rp 1 ½	Rp 1 ½		
RGB-85/LN	GT2	Rp 1 ½	Rp 1 ½	-	11.7
	GT4	Rp 1 ½	Rp 1 ½		
RGB-110	GT2	Rp 1 ½	Rp 2	-	9
	GT4	Rp 1 ½	Rp 2		
RGB-130/LN	GT3	Rp 2	Rp 2	-	22.5
	GT5	Rp 2	Rp 2		
RGB-145	GT3	Rp 2	Rp 2	-	8.6
	GT5	Rp 2	Rp 2		
RGB-175/LN	GT3	Rp 2	Rp 2	-	17
RGB-185	GT3	Rp 2	Rp 2	-	14.5
RGB-205	GT3	Rp 2	Rp 2	-	14.5
RGB-255/LN	GT3	Rp 2	Rp 2	-	24.9
RGB-305	GT6	DN 65	Rp 2	-	20.6
RGB-385	GT6	DN 65	Rp 2	-	31.7
RGB-405/LN	GT6	DN 65	Rp 2	-	47
RGB-505/LN	GT6	DN 65	Rp 2	-	56
RGB-605	GT6	DN 65	Rp 2	-	62.8

RLGB-Series					
Burner	Gas model	Gas train size	Main solenoid valve size	$\Delta P B. V^*$	$\Delta P C.H^{**}$ (mbar)
RLGB-55	GT2	Rp 1 ½	Rp 1 ½	-	14
	GT4	Rp 1 ½	Rp 1 ½		
RLGB-85	GT2	Rp 1 ½	Rp 1 ½	-	6.2
	GT4	Rp 1 ½	Rp 1 ½		
RLGB-110	GT2	Rp 1 ½	Rp 2	-	10
	GT4	Rp 1 ½	Rp 2		
RLGB-145	GT3	Rp 2	Rp 2	-	13
	GT5	Rp 2	Rp 2		
RLGB-175/LN	GT3	Rp 2	Rp 2	-	17
	GT5	Rp 2	Rp 2		
RLGB-205/LN	GT3	Rp 2	Rp 2	-	21.5
RLGB-255	GT6	Rp 2	Rp 2	-	27.8
RLGB-305/LN	GT6	DN 65	Rp 2	-	23
RLGB-385/LN	GT6	DN 65	Rp 2	-	27.3
RLGB-405/LN	GT6	DN 65	Rp 2	-	44
RLGB-505/LN	GT6	DN 65	Rp 2	-	47
RLGB-605/LN	GT6	DN 65	Rp 2	-	68

\*Butterfly Valve: In raadman-Staging version, since there is no link between air and gas inlets, no butterfly valve is used. As a result, its relative pressure drop is considered to be zero.

\*\*Combustion Head.



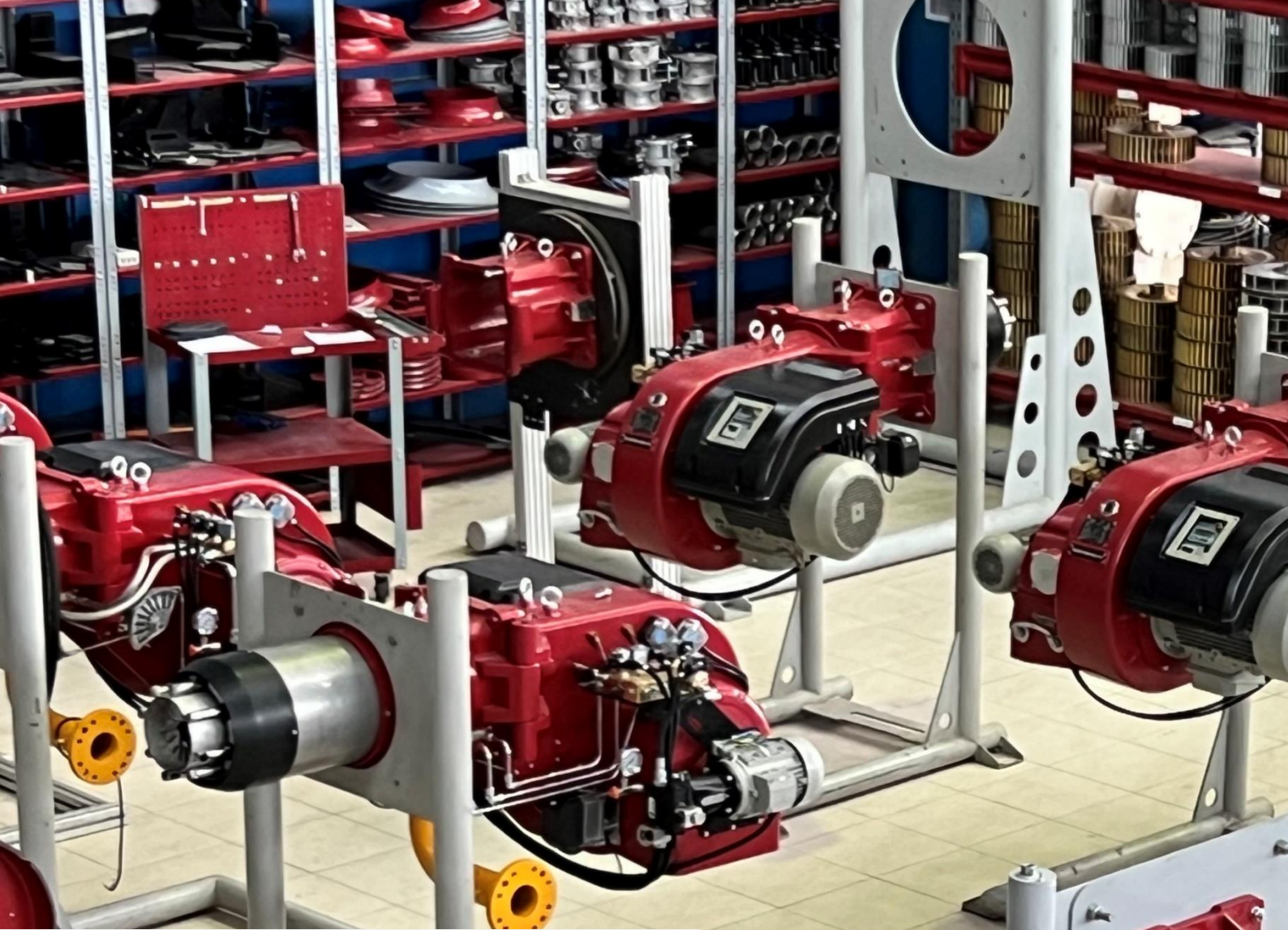

Production Hall of raadman burner Factory- 2023

- raadman -

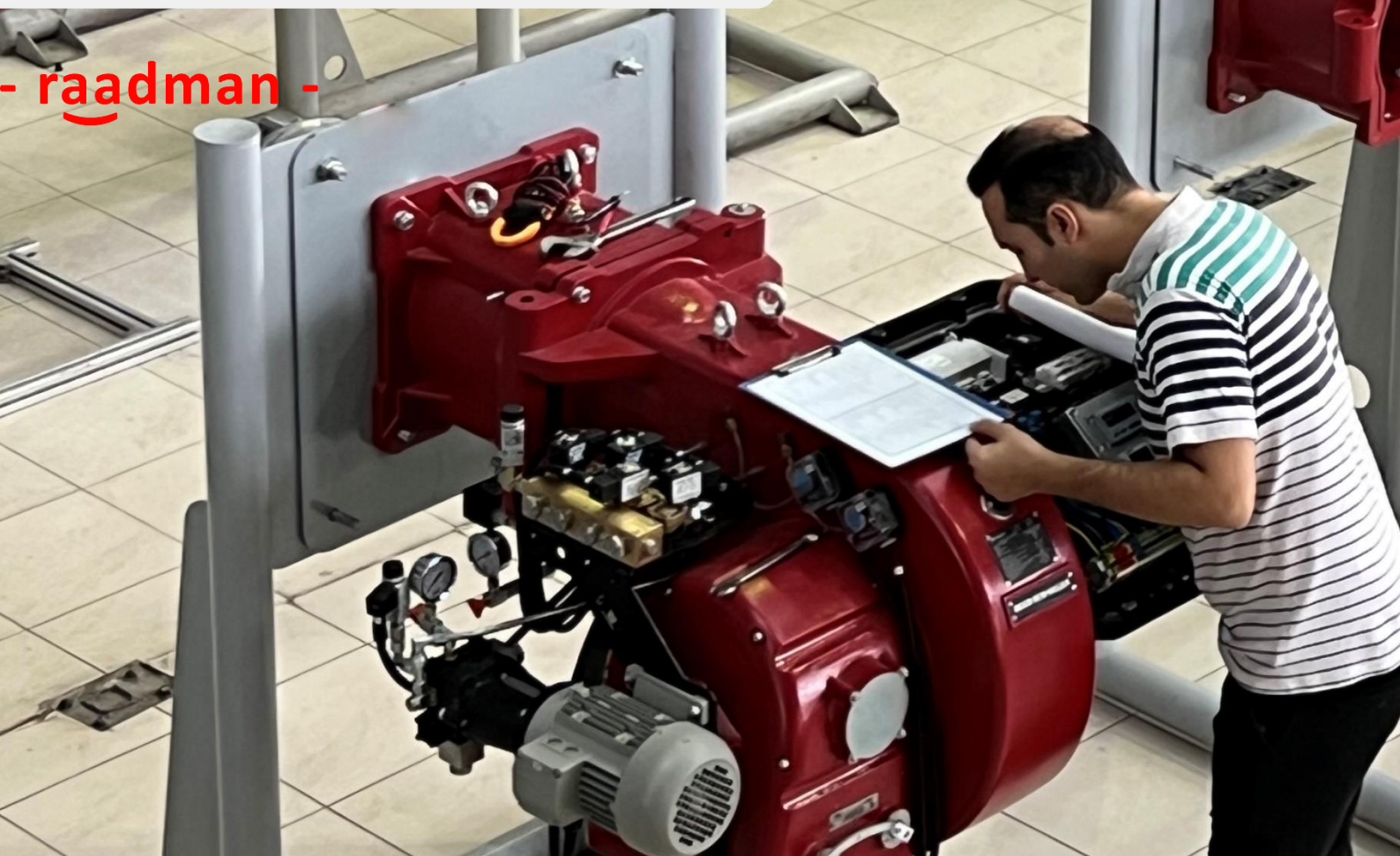

# Emission

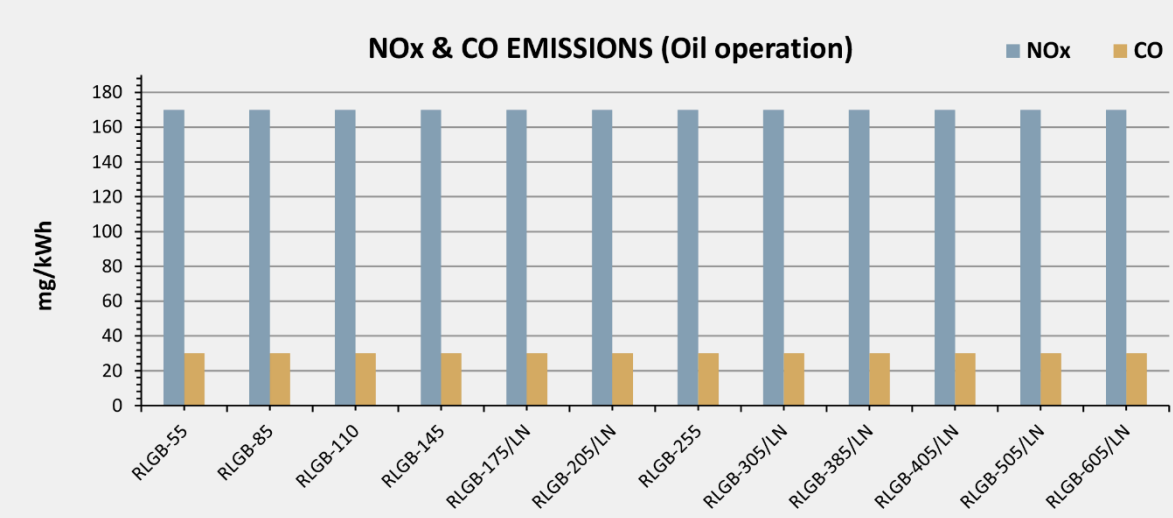
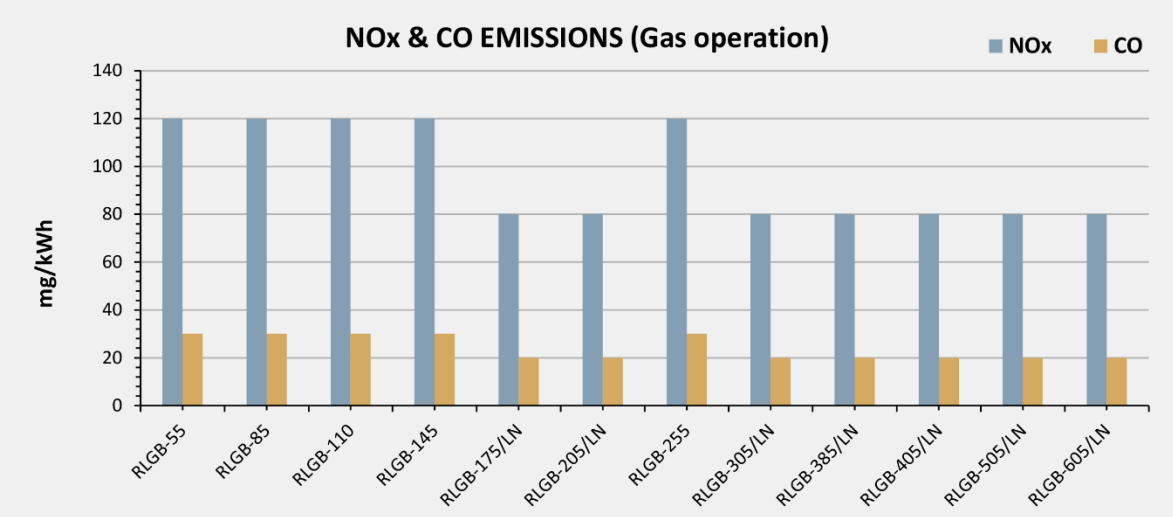
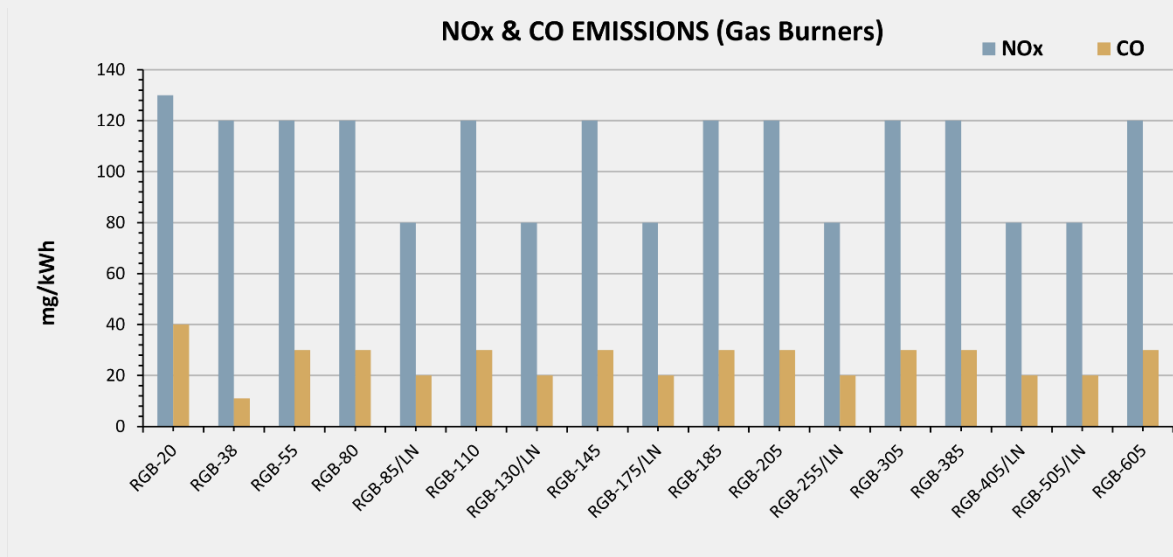



### Noise Level (RGB Series)

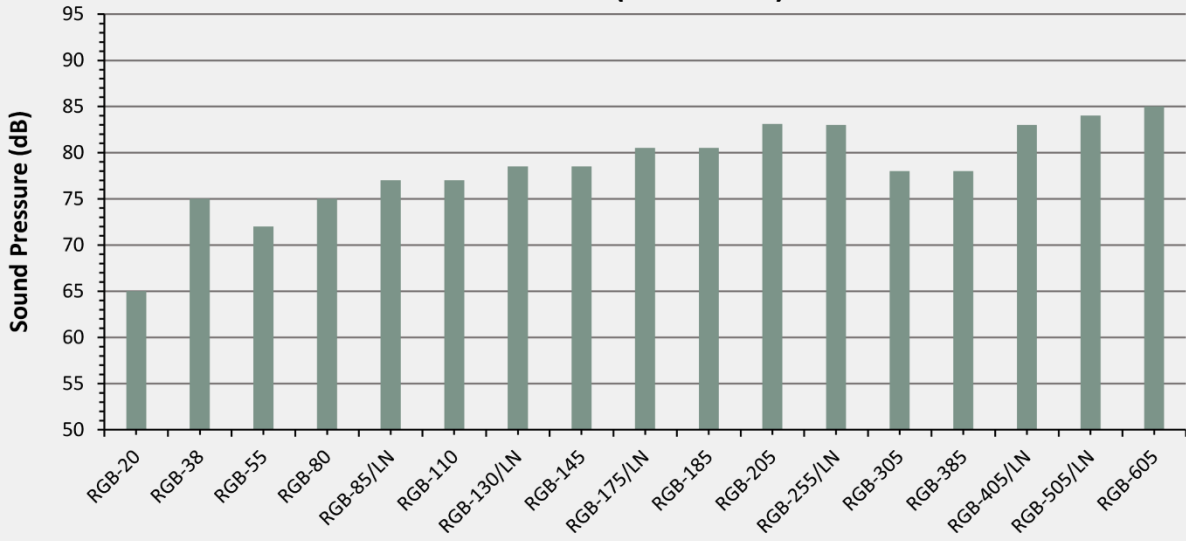

### Noise Level (RLGB Series)

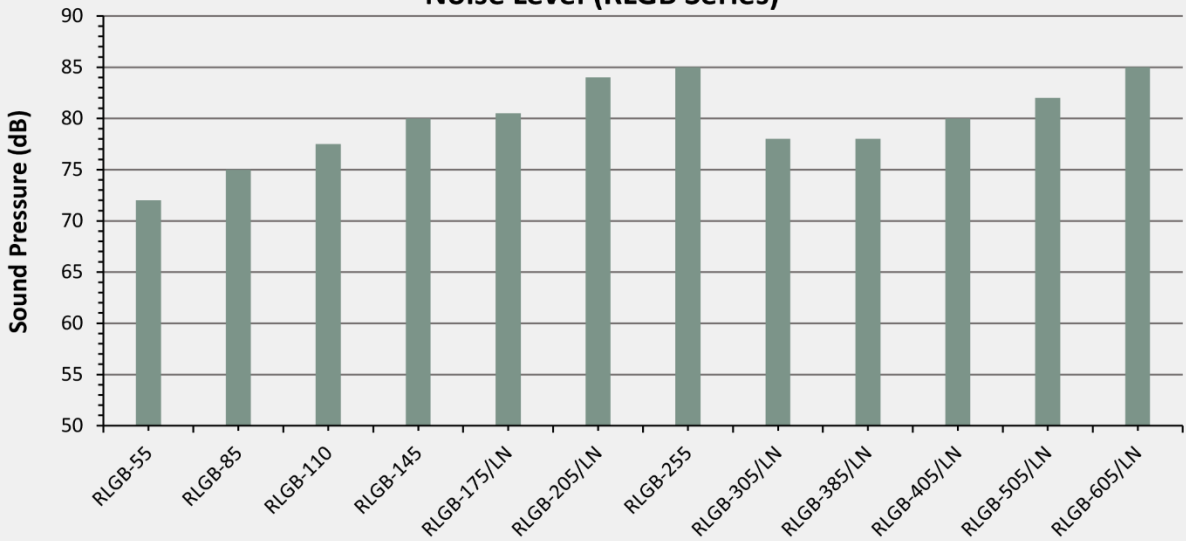





- raadman -

# Mechanical Staging Mono Block Burners

Heat Rated Output: 300-6200 kW



- SMILE INTO THE FUTURE -

[www.raadmanburner.com](http://www.raadmanburner.com)



## raadman mechanical staging burners

raadman mechanical staging burners cover a firing range of 1000 to 6200 kW, and they are manufactured with high quality electro-mechanical accessories with easy installation and commissioning.

Thanks to the cam mechanism and butterfly valve we have “Staging” operation in gas side. In this type of burner, one actuator opens the damper and butterfly valve to reach the desired stages.

The components of these burners are as follows:

Mechanical components, burner head, flame tube, and cam mechanism, safety accessories, ignition devices, flame scanners, burners controllers such as Shokouh/Honeywell TMG or Siemens LFL, burner actuators, accessories of power system, ventilation motor, fan wheel, safety devices, and air pressure switches.

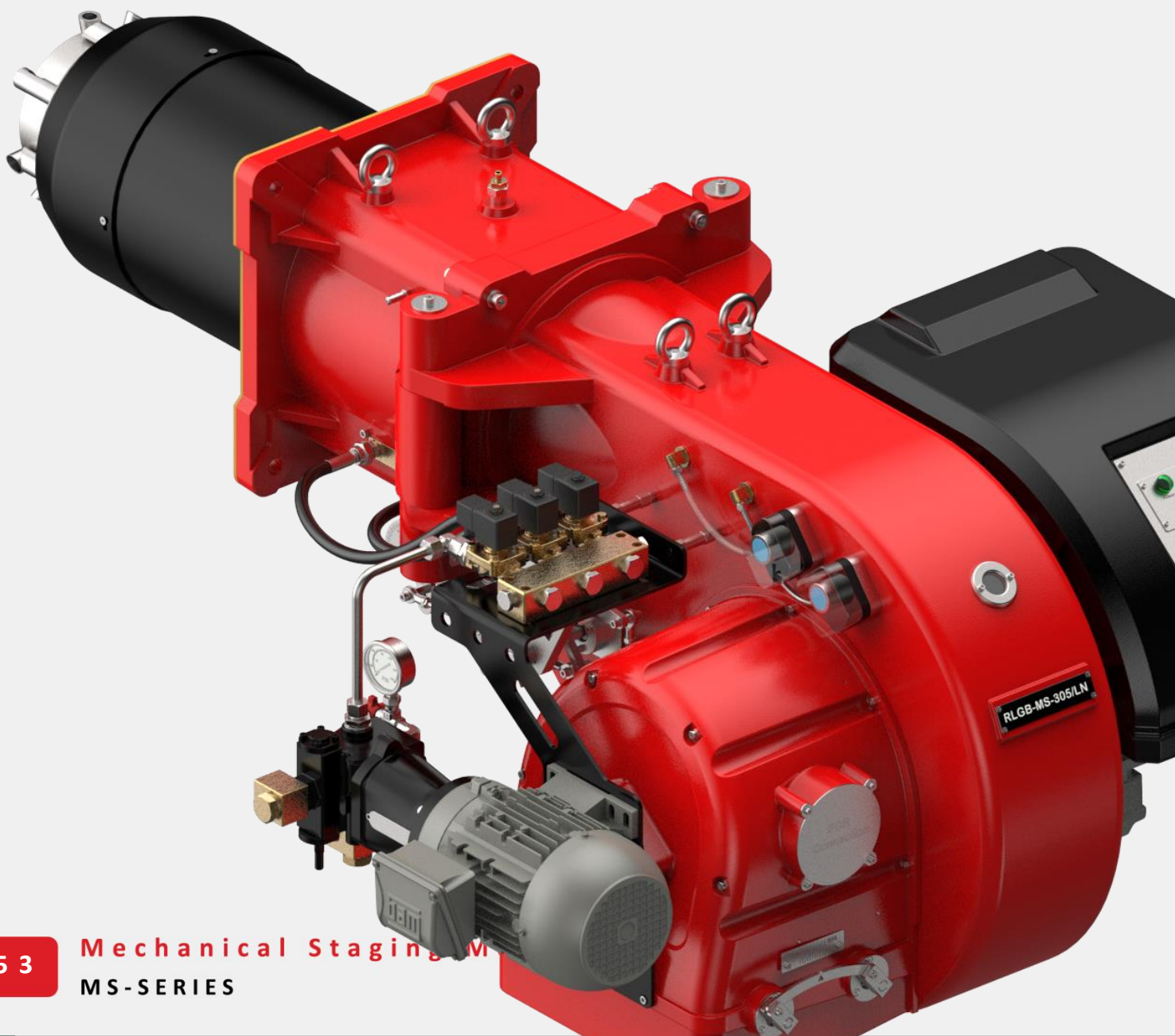



# Burner management system overview

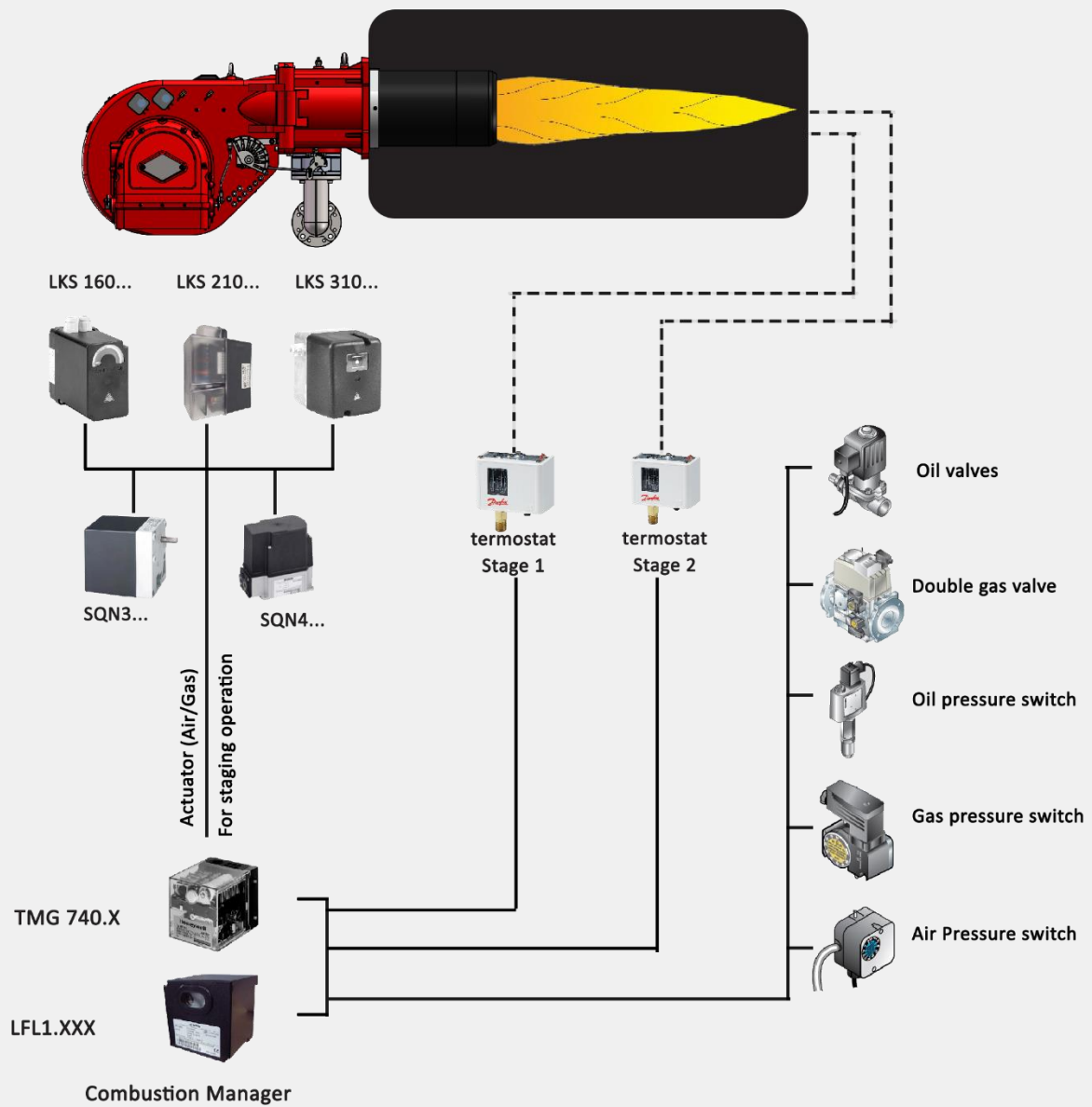

To obtain staging operation, the RGB-MS series of burners require two thermostats and actuator with 2-stage.

# raadman RGB-MS series burner





# Burner Selection: capacity and working diagram

## Gas Burner

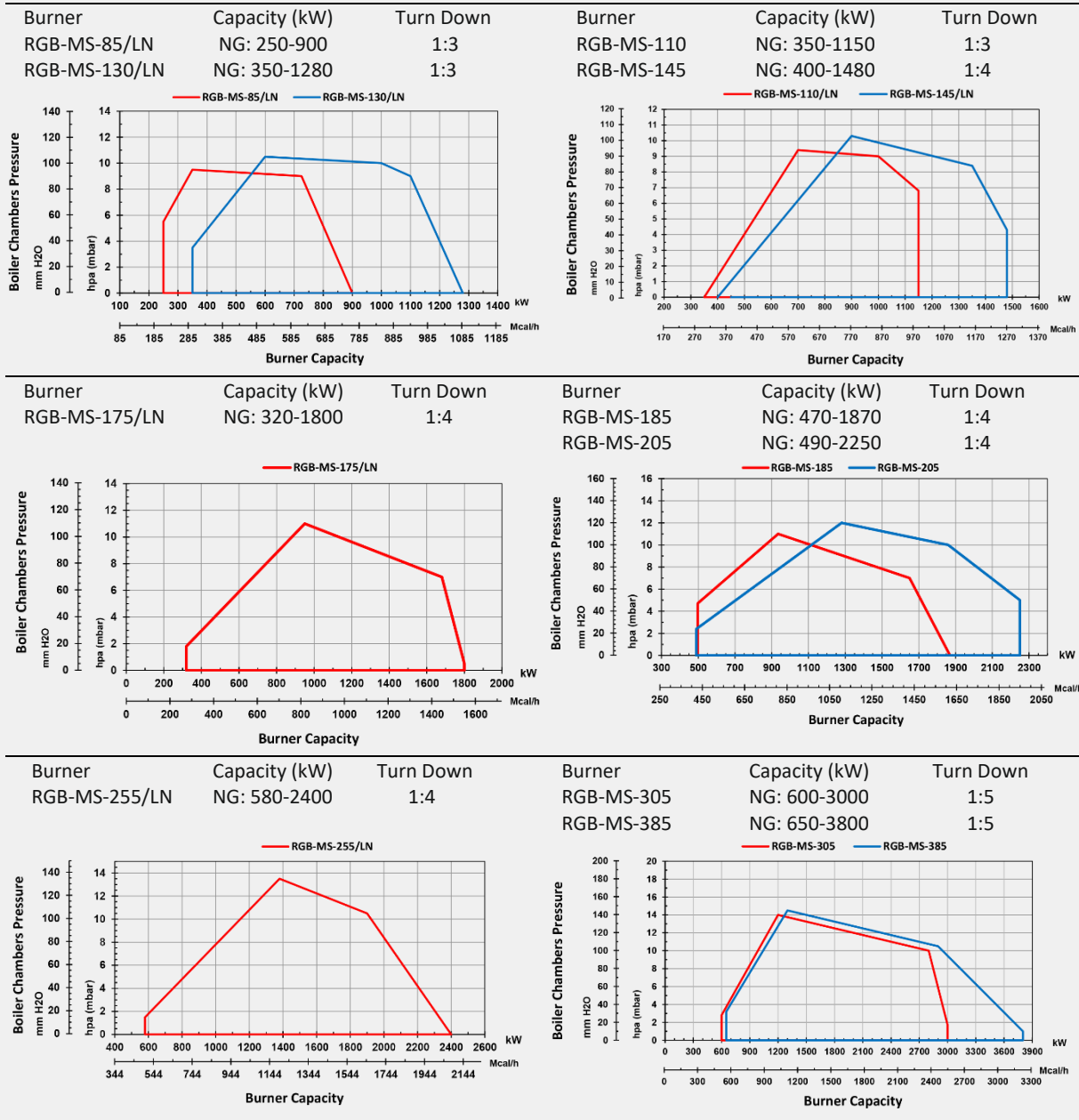

Note: About the working diagram

Working diagram for gas burner is certified in accordance with EN 676. The firing rate diagram has been obtained considering ambient temperature of 20°C and atmospheric pressure of 1013 mbar (Sea level condition). For installation at higher altitudes, a reduction in capacity of 1% per 100 m above sea level should be taken into account.



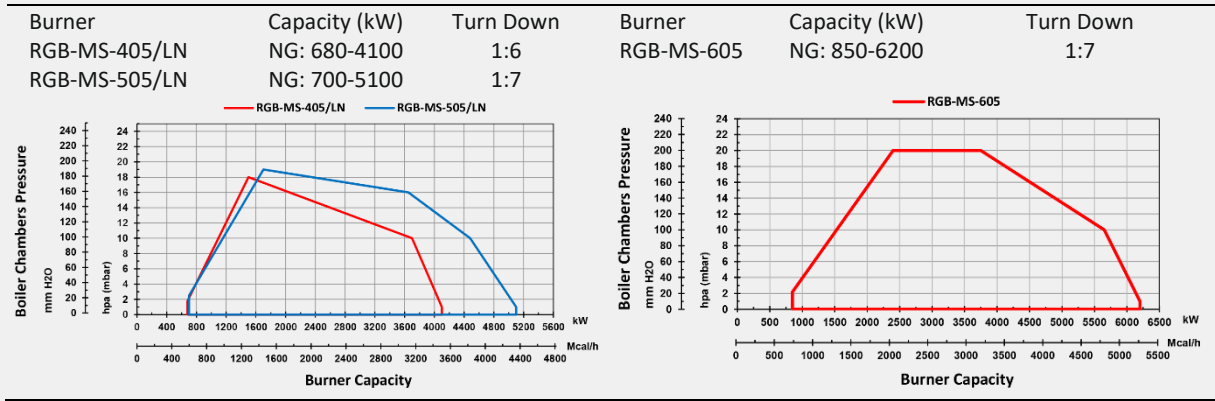

# General dimension: RGB-MS series

RGB-MS-85/LN, RGB-MS-130/LN

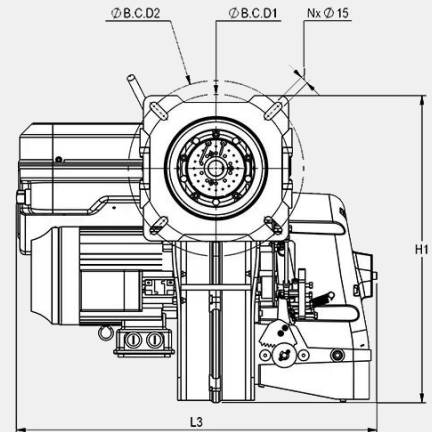
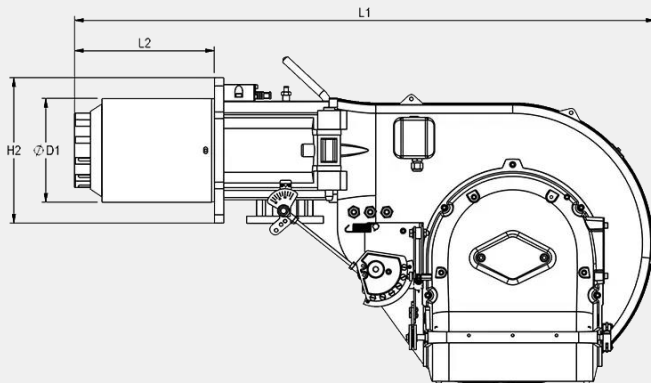

Burner Type	L <sub>1</sub>	L <sub>2</sub>	L <sub>3</sub>	H <sub>1</sub>	H <sub>2</sub>	D <sub>1</sub>	D <sub>2</sub>	N	B.C.D.1	B.C.D.2
RGB-MS-85/LN	1068	255	641	600	265	193	15	4	270	320
RGB-MS-130/LN	1072	260	641	600	265	193	15	4	270	320

RGB-MS-110, RGB-MS-145

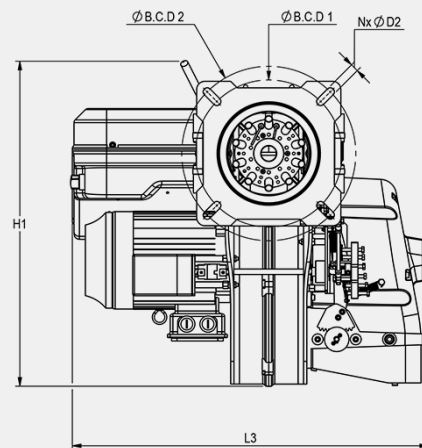
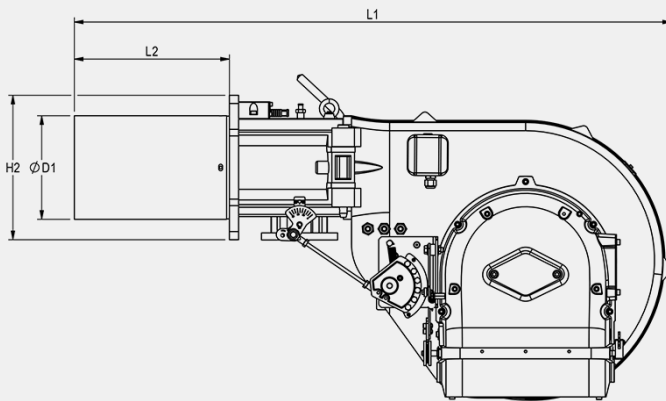

Burner Type	L <sub>1</sub>	L <sub>2</sub>	L <sub>3</sub>	H <sub>1</sub>	H <sub>2</sub>	D <sub>1</sub>	D <sub>2</sub>	N	B.C.D.1	B.C.D.2
RGB-MS-110	1066	254	643	600	265	184	15	4	270	320
RGB-MS-145	1097	285	643	600	265	194	15	4	270	320

### RGB-MS-175/LN

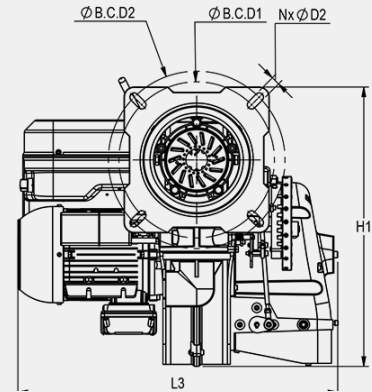
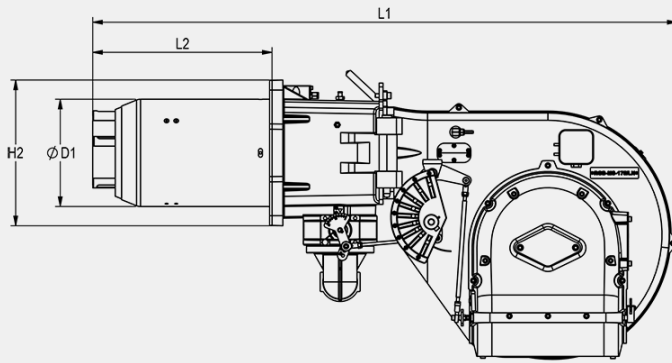

Burner Type	L <sub>1</sub>	L <sub>2</sub>	L <sub>3</sub>	H <sub>1</sub>	H <sub>2</sub>	D <sub>1</sub>	D <sub>2</sub>	N	B.C.D.1	B.C.D.1
RGB-MS-175/LN	1213	373	665	598	302	226	18	4	323	367

### RGB-MS-185, RGB-MS-205

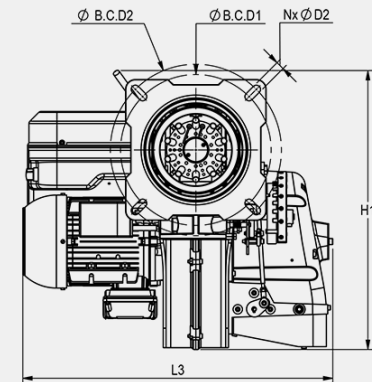
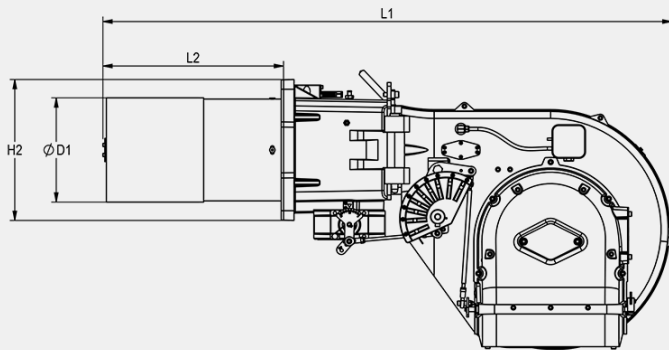

Burner Type	L <sub>1</sub>	L <sub>2</sub>	L <sub>3</sub>	H <sub>1</sub>	H <sub>2</sub>	D <sub>1</sub>	D <sub>2</sub>	N	B.C.D.1	B.C.D.1
RGB-MS-185	1229	388	666	598	302	223	18	4	323	367
RGB-MS-205	1229	388	666	598	302	223	18	4	323	367

### RGB-MS-255/LN

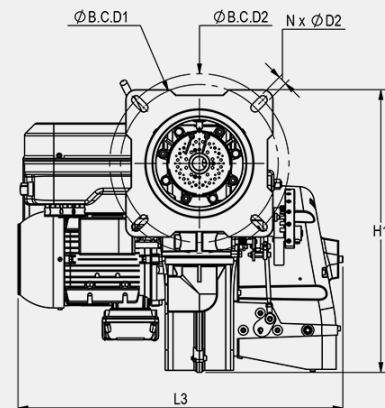
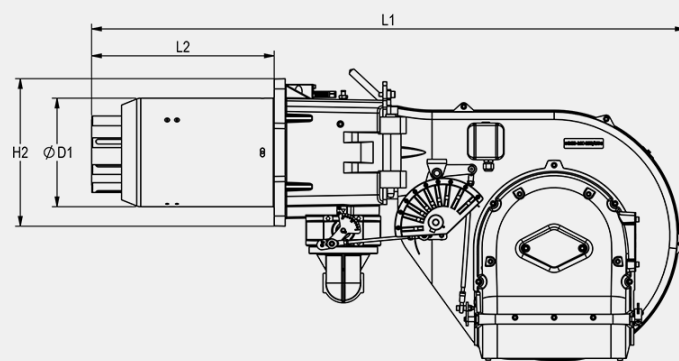

Burner Type	L <sub>1</sub>	L <sub>2</sub>	L <sub>3</sub>	H <sub>1</sub>	H <sub>2</sub>	D <sub>1</sub>	D <sub>2</sub>	N	B.C.D.1	B.C.D.2
RGB-MS-255/LN	1214	374	762	598	302	226	18	4	323	368



### RGB-MS-305, RGB-MS-385

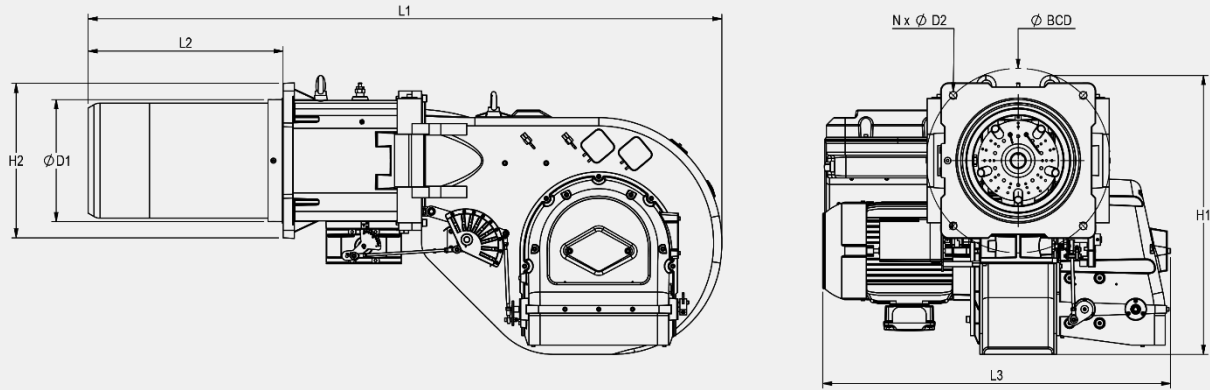

Burner Type	L <sub>1</sub>	L <sub>2</sub>	L <sub>3</sub>	H <sub>1</sub>	H <sub>2</sub>	D <sub>1</sub>	D <sub>2</sub>	N	B.C. D
RGB-MS-305	1689	520	927	741	413	328	20	4	490
RGB-MS-385	1689	520	927	741	413	328	20	4	490

### RGB-MS-405/LN, RGB-MS-505/LN

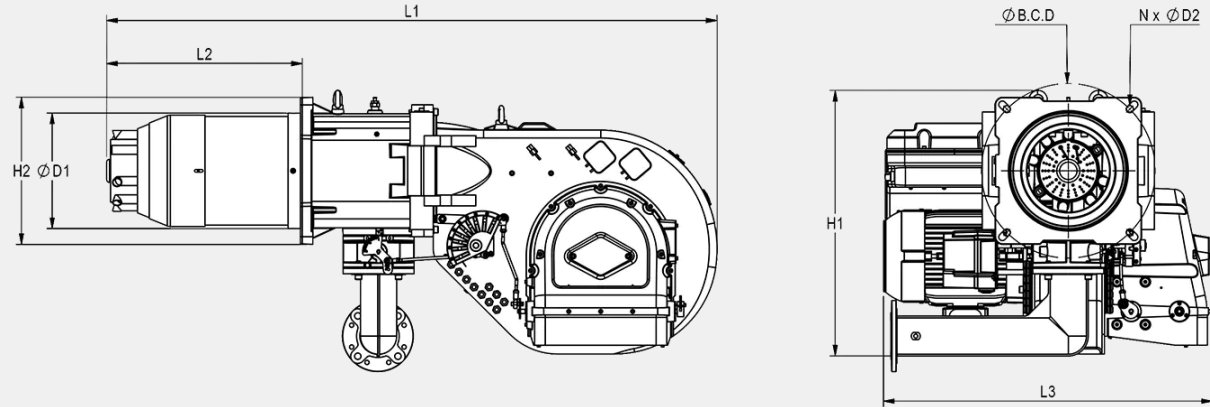

Burner Type	L <sub>1</sub>	L <sub>2</sub>	L <sub>3</sub>	H <sub>1</sub>	H <sub>2</sub>	D <sub>1</sub>	D <sub>2</sub>	N	B.C. D
RGB-MS-405/LN	1721	552	930	798	413	328	20	4	490
RGB-MS-505/LN	1721	552	930	798	413	328	20	4	490

### RGB-MS-605

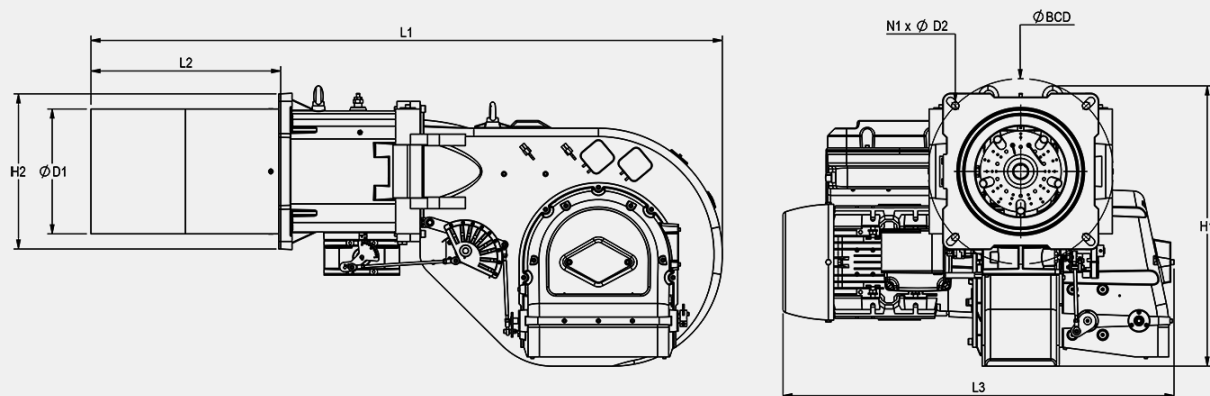

Burner Type	L <sub>1</sub>	L <sub>2</sub>	L <sub>3</sub>	H <sub>1</sub>	H <sub>2</sub>	D <sub>1</sub>	D <sub>2</sub>	N	B.C. D
RGB-MS-605	1665	502	1035	741	410	336	20	4	490

## Technical data: RGB-MS series

RGB-MS series burner includes ventilation system with AC motor, ignition transformer, and electrodes, electrical panel with power contactors, fuses, relays, central controller, air pressure switches, soundproofing material, lamp signals for operational supervision, etc.

- N.G operation: Mechanical Staging

Burner	Power system		Power management system	
	Motor(kW/PH/V/HZ/rpm)		Controller	Actuator (N.M)
RGB-MS-85/LN	1.5 /3 /380-400 /50 /2840		Shokouh/ Siemens	2.5 or 3
RGB-MS-110	1.5 /3 /380-400 /50 /2840		Shokouh/ Siemens	2.5 or 3
RGB-MS-130/LN	2.2 /3 /380-400 /50 /2840		Shokouh/ Siemens	2.5 or 3
RGB-MS-145	2.2 /3 /380-400 /50 /2840		Shokouh/ Siemens	2.5 or 3
RGB-MS-175/LN	4 /3 /380-400 /50 /2840		Shokouh/ Siemens	3
RGB-MS-185	5.5 /3 /380-400 /50 /2840		Shokouh/ Siemens	3
RGB-MS-205	5.5 /3 /380-400 /50 /2840		Shokouh/ Siemens	3
RGB-MS-255/LN	5.5 /3 /380-400 /50 /2840		Shokouh/ Siemens	3
RGB-MS-305	7.5 /3 /380-400 /50 /2900		Siemens	10
RGB-MS-385	7.5 /3 /380-400 /50 /2900		Siemens	10
RGB-MS-405/LN	11 /3 /380-400 /50 /2900		Siemens	10
RGB-MS-505/LN	11 /3 /380-400 /50 /2900		Siemens	10
RGB-MS-605	15 /3 /380-400 /50 /2900		Siemens	10



- raadman



# raadman RLGB-MS series burner

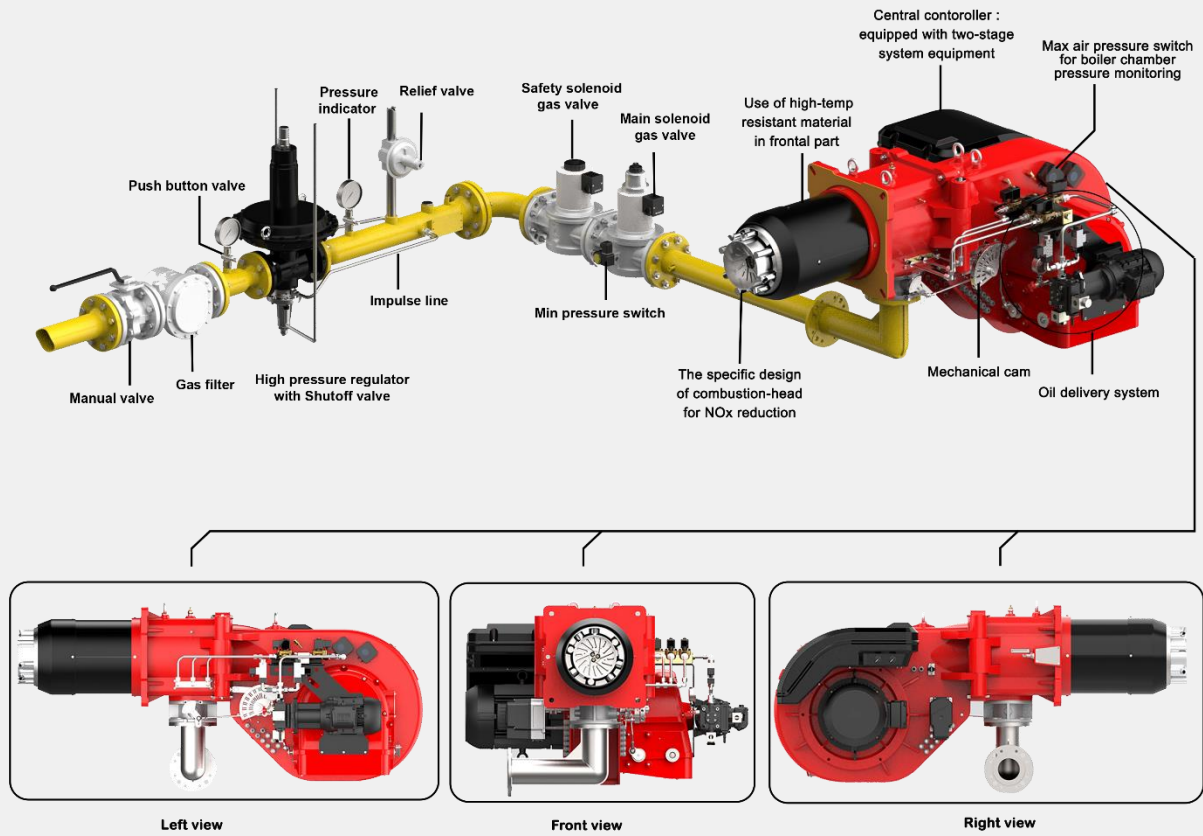



# Burner selection: capacity and working diagram

## Dual-fuel Burner

Burner	Capacity (kW)	Turn down	Burner	Capacity (kW)	Turn down
RLGB-MS-110	NG: 350-1100 LFO: 350-1100	1:3	RLGB-MS-175/LN	NG: 320-1800 LFO: 320-1800	1:5
RLGB-MS-145	NG: 400-1380 LFO: 400-1380	1:4	RLGB-MS-205/LN	NG: 450-2200 LFO: 450-2200	1:5

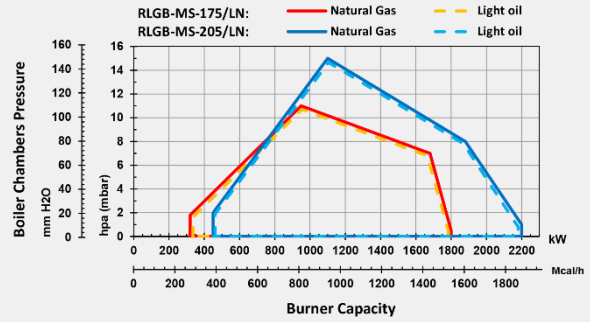
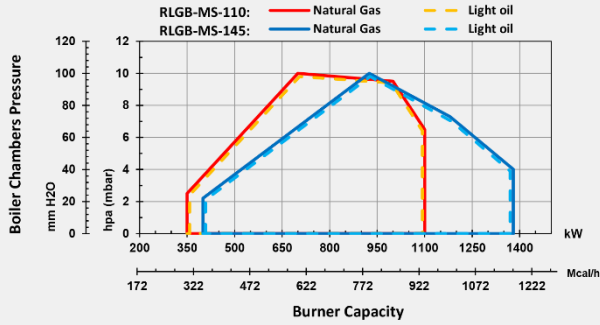

Burner	Capacity (kW)	Turn down	Burner	Capacity (kW)	Turn down
RLGB-MS-305/LN	NG: 600-3000 LFO: 600-3000	1:5	RLGB-MS-405/LN	NG: 680-4100 LFO: 680-4100	1:6
RLGB-MS-385/LN	NG: 650-3500 LFO: 650-3500	1:5	RLGB-MS-505/LN	NG: 700-5100 LFO: 700-5100	1:7

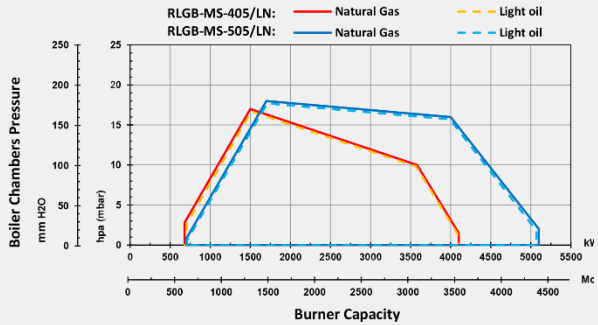
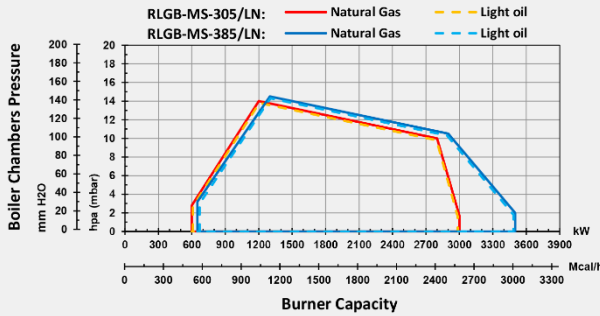

Burner	Capacity (kW)	Turn down	Burner	Capacity (kW)	Turn down
RLGB-MS-255	NG: 580-2400 LFO: 580-2400	1:4	RLGB-MS-605/LN	NG: 1000-6100 LFO: 1000-6100	1:6

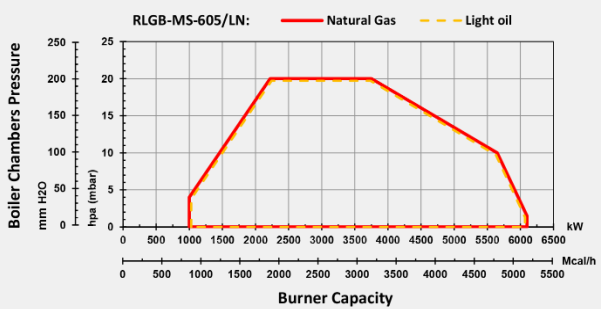
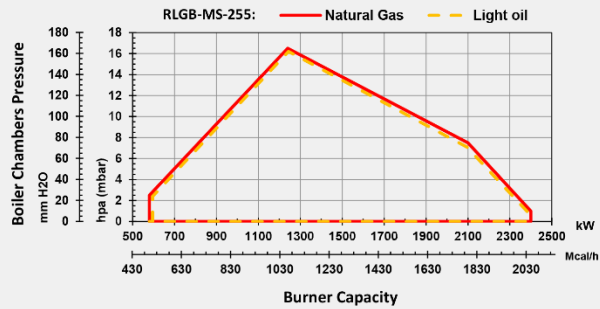

Working diagrams for gas and light fuel oil burner are certified in accordance with BS-EN 676 and BS-EN 267. The firing rate diagram has been obtained considering the ambient temperature of 20°C and atmospheric pressure of 1013 mbar (Sea level condition).

# General dimension: RLGB-MS series

## RLGB-MS-110, RLGB-MS-145

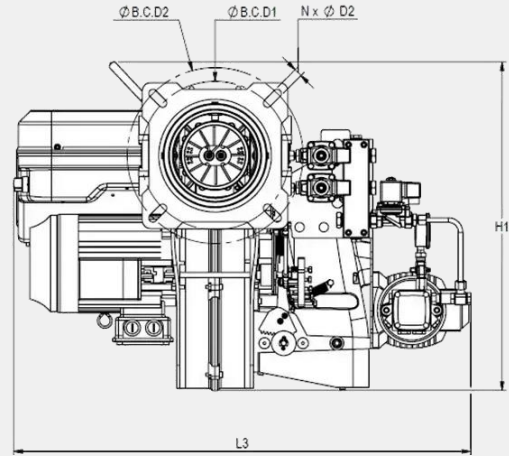
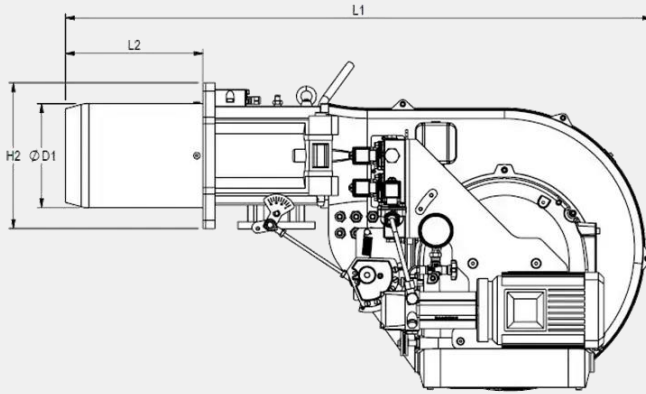

Burner Type	L <sub>1</sub>	L <sub>2</sub>	L <sub>3</sub>	H <sub>1</sub>	H <sub>2</sub>	D <sub>1</sub>	D <sub>2</sub>	N	B.C. D1	B.C. D2
RLGB-MS-110	1068	255	830	598	265	184	15	4	270	320
RLGB-MS-145	1068	255	830	598	265	194	15	4	270	320

## RLGB-MS-175/LN, RLGB-MS-205/LN

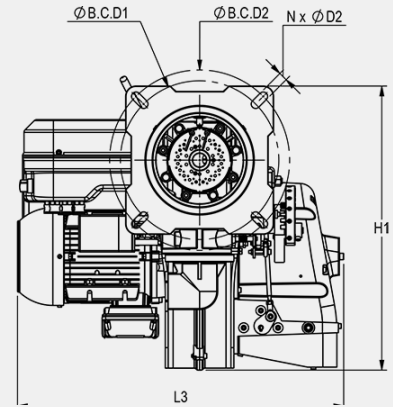
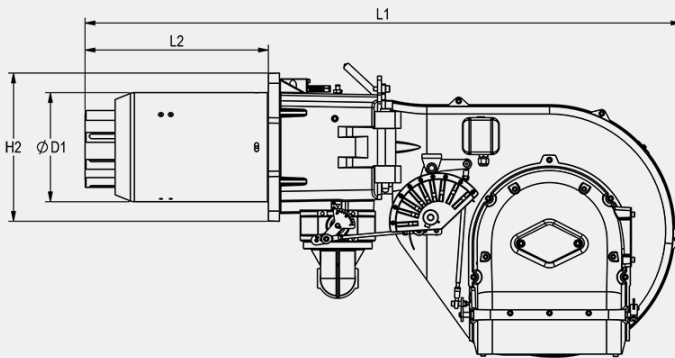

Burner Type	L <sub>1</sub>	L <sub>2</sub>	L <sub>3</sub>	H <sub>1</sub>	H <sub>2</sub>	D <sub>1</sub>	D <sub>2</sub>	N	B.C. D1	B.C. D2
RLGB-MS-175/LN	1213	373	875	598	300	226	18	4	323	367
RLGB-MS-205/LN	1213	373	875	598	300	226	18	4	323	367



### RLGB-MS-255

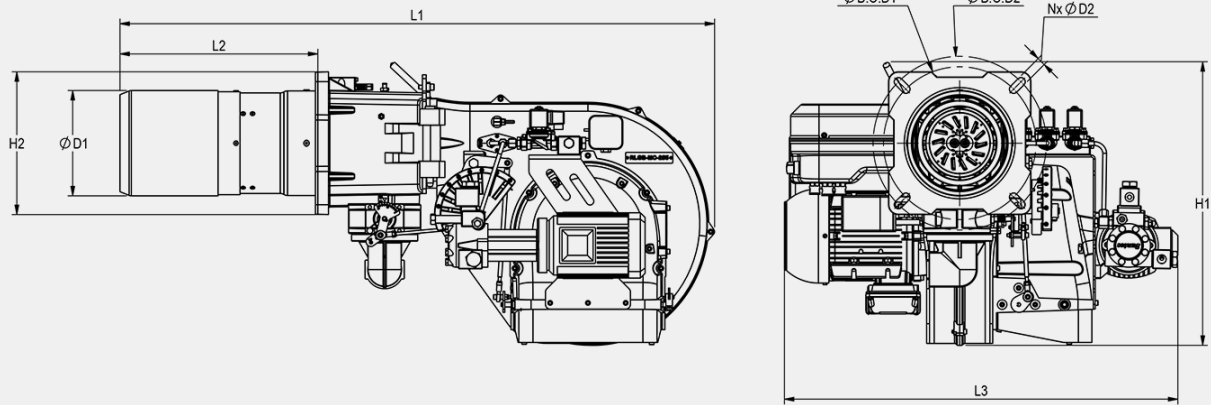

Burner Type	L <sub>1</sub>	L <sub>2</sub>	L <sub>3</sub>	H <sub>1</sub>	H <sub>2</sub>	D <sub>1</sub>	D <sub>2</sub>	N	B.C. D1	B.C. D2
RLGB-MS-255	1260	419	833	598	300	223	18	4	323	367

### RLGB-MS-305/LN, RLGB-MS-385/LN, RLGB-MS-405/LN, RLGB-MS-505/LN, RLGB-MS-605/LN

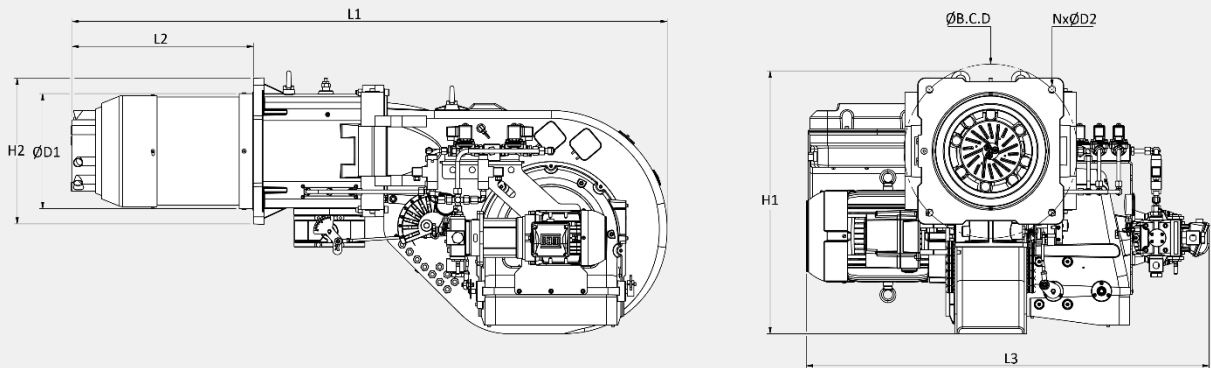

Burner Type	L <sub>1</sub>	L <sub>2</sub>	L <sub>3</sub>	H <sub>1</sub>	H <sub>2</sub>	D <sub>1</sub>	D <sub>2</sub>	N	B.C. D
RLGB-MS-305/LN	1683	514	1137	741	410	328	20	4	490
RLGB-MS-385/LN	1683	514	1137	741	410	328	20	4	490
RLGB-MS-405/LN	1683	514	1249	741	410	328	20	4	490
RLGB-MS-505/LN	1683	514	1249	741	410	328	20	4	490
RLGB-MS-605/LN	1680	512	1245	741	410	340	20	4	490

## Technical data: RLGB-MS series

- N.G operation: Mechanical Staging
- LFO operation: II or III Stages

Burner	Power system	Power management system	
	Motor(kW/PH/V/HZ/rpm)	Controller	Actuator (N.M)
RLGB-MS-110	1.5 /3 /380-400 /50 /2840	Shokouh/ Siemens	2.5 or 3
RLGB-MS-145	2.2 /3 /380-400 /50 /2840	Shokouh/ Siemens	2.5 or 3
RLGB-MS-175/LN	4 /3 /380-400 /50 /2840	Shokouh/ Siemens	3
RLGB-MS-205/LN	5.5 /3 /380-400 /50 /2840	Shokouh/ Siemens	3
RLGB-MS-255	5.5 /3 /380-400 /50 /2840	Shokouh/ Siemens	3
RLGB-MS-305/LN	7.5 /3 /380-400 /50 /2940	Siemens	10
RLGB-MS-385/LN	7.5 /3 /380-400 /50 /2940	Siemens	10
RLGB-MS-405/LN	11 /3 /380-400 /50 /2940	Siemens	10
RLGB-MS-505/LN	11 /3 /380-400 /50 /2940	Siemens	10
RLGB-MS-605/LN	15 /3 /380-400 /50 /2920	Siemens	10

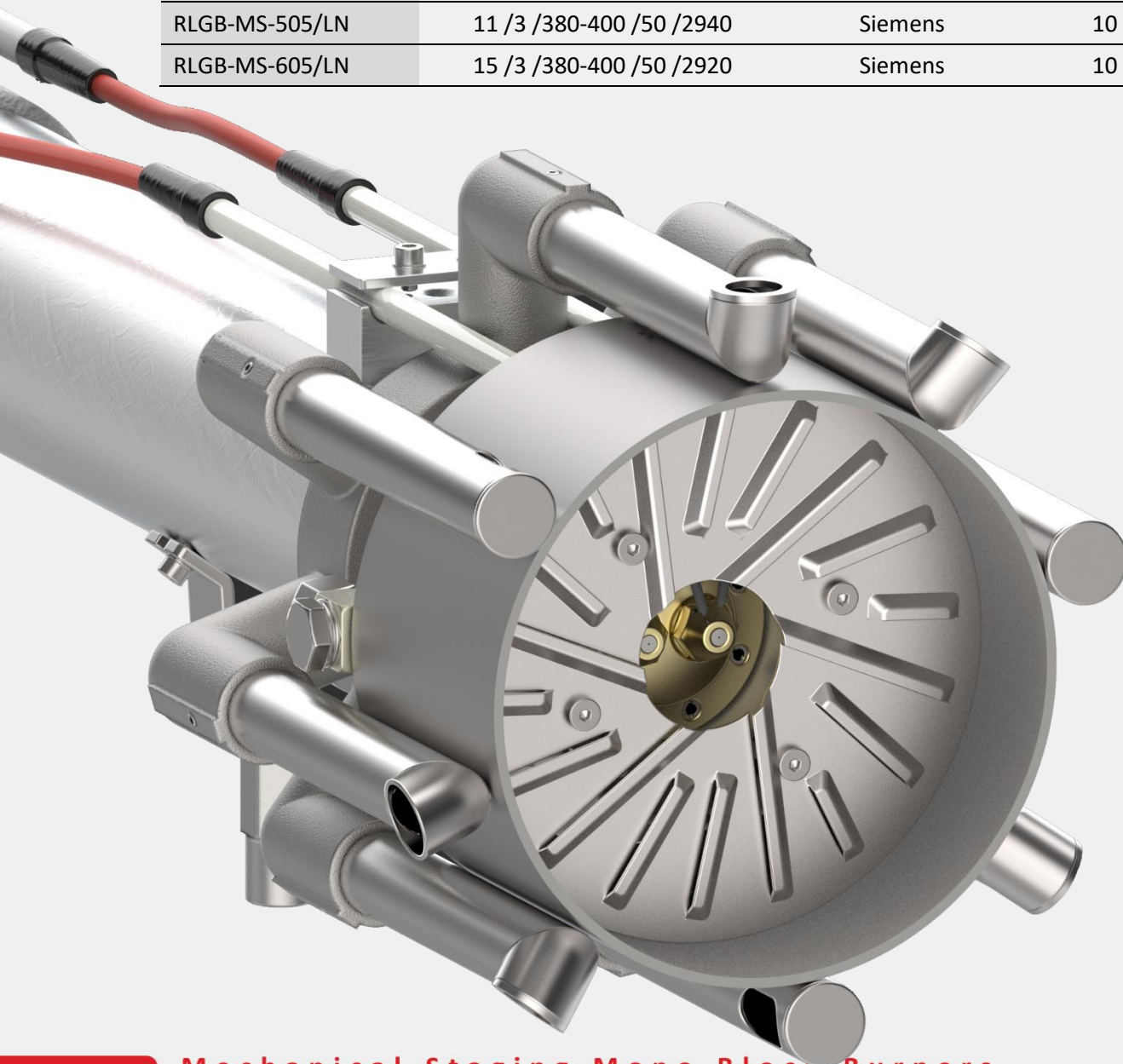



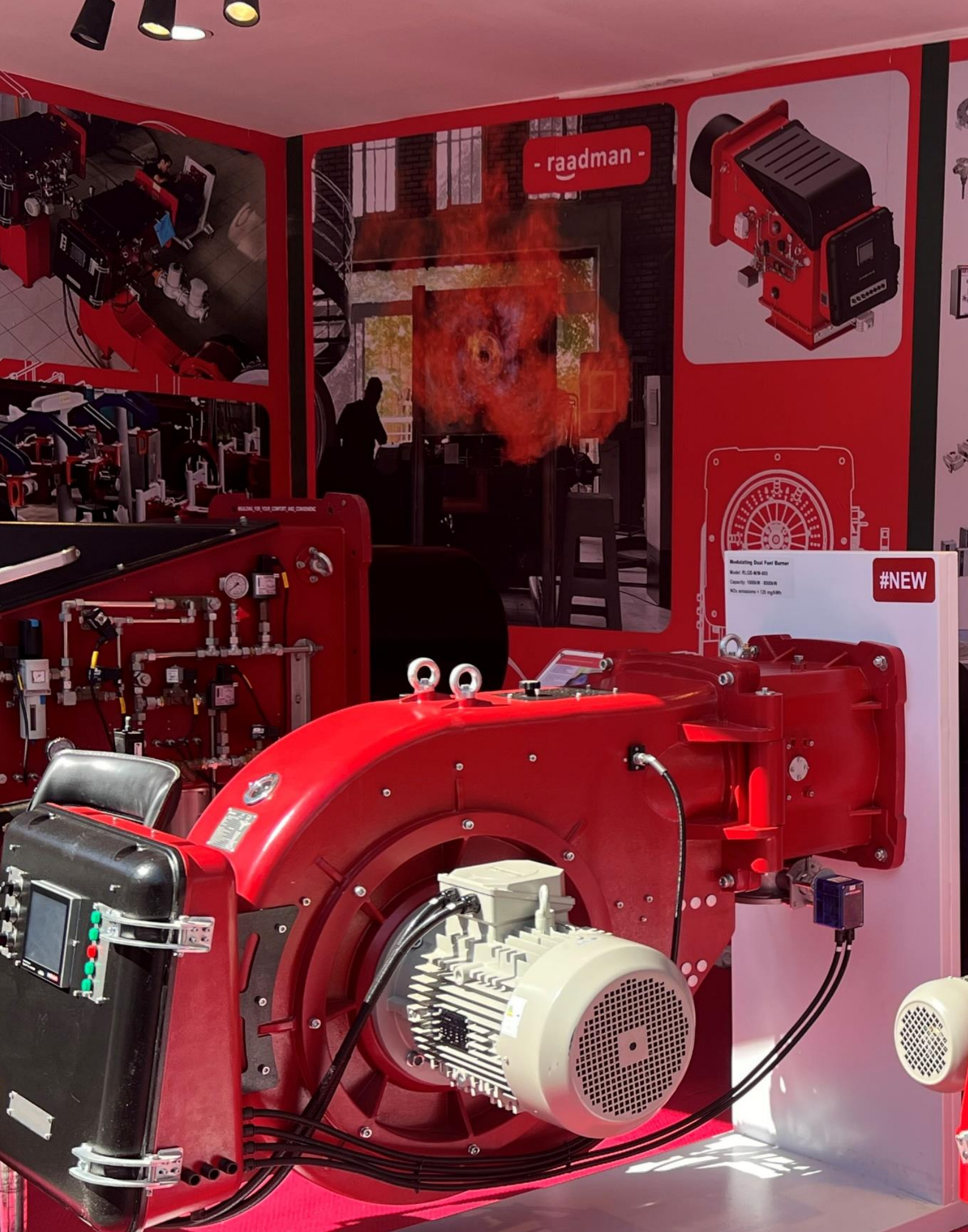

- raadman -



Modulating Dual Fuel Burner  
Water: FLGD-MW-433  
Capacity: 1000W - 8000W  
NOx emissions: 1.20 mg/kWh

#NEW

22<sup>nd</sup> International Exhibition of HVAC&R, 2023-Tehran, Iran



# Gas train diagram

**GT1** (Pressure input < 360 mbar, separated items)

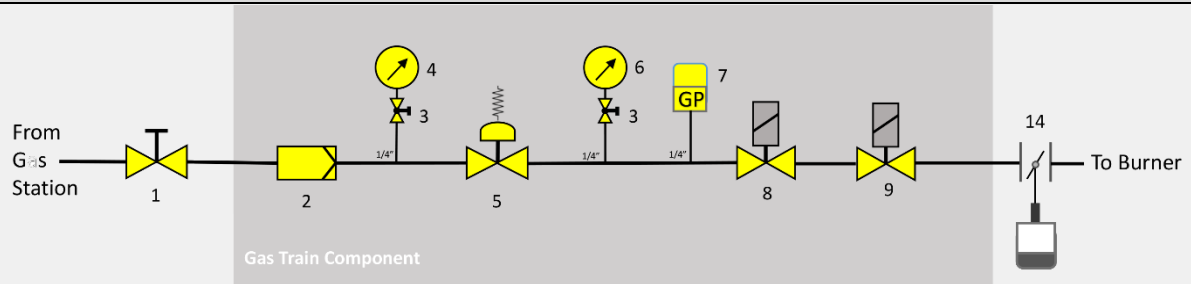

**GT2** (Pressure input < 360 mbar, multi bloc gas train)

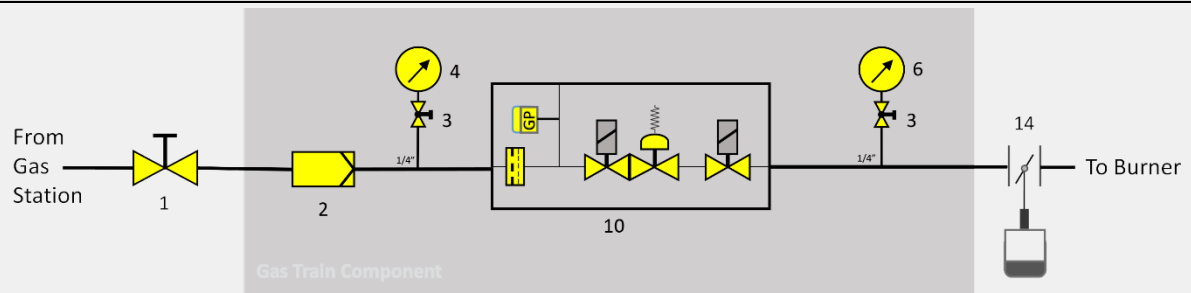

**GT3** (Pressure input < 360 mbar, separated items, with valve proving system)

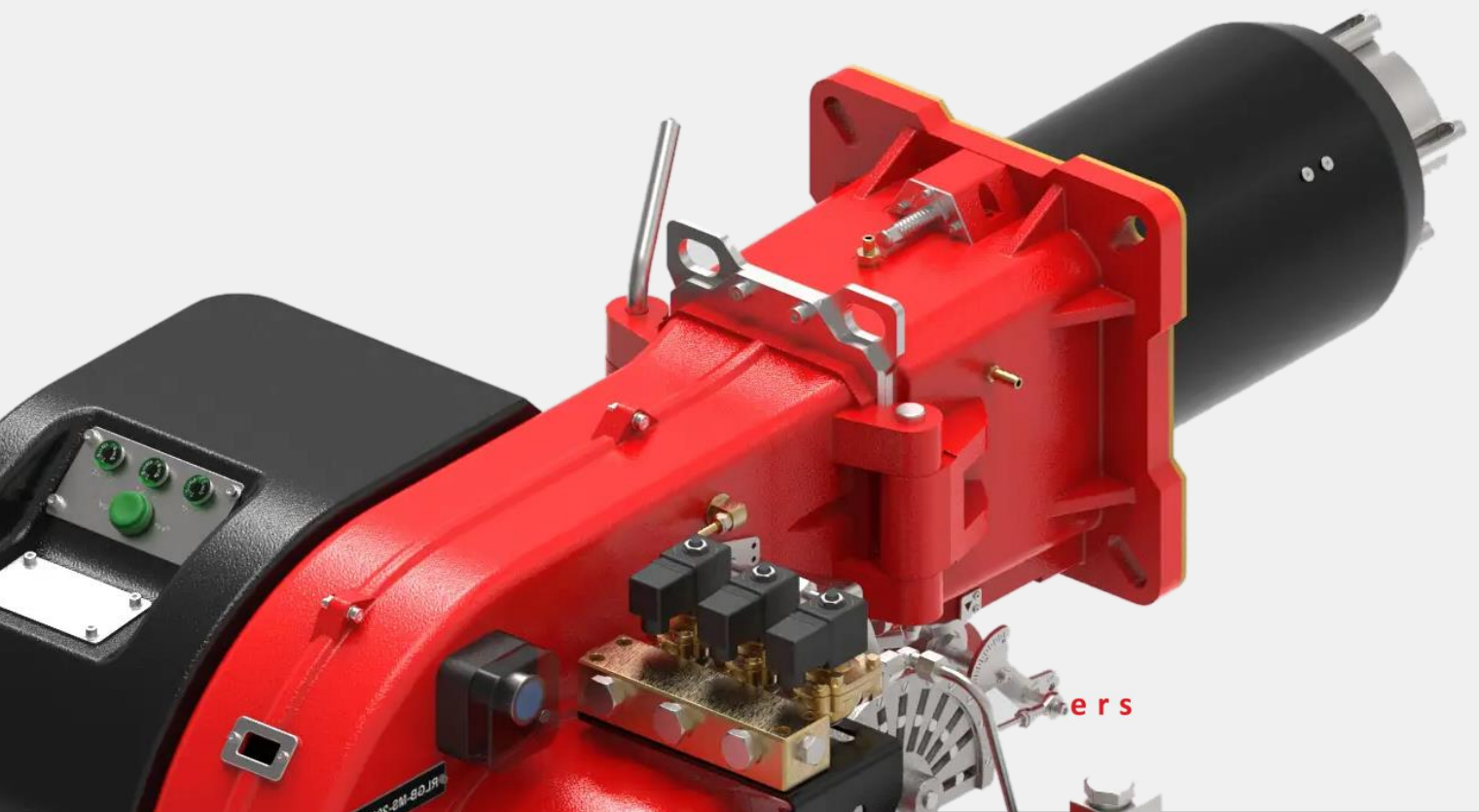
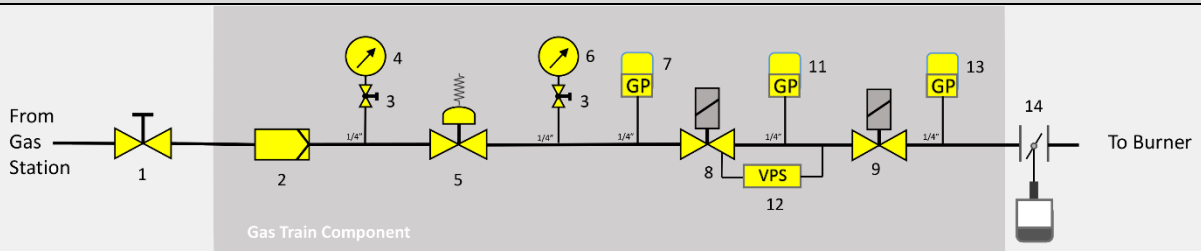

## GT4 (Pressure input < 360 mbar, multi bloc gas train, with valve proving system)

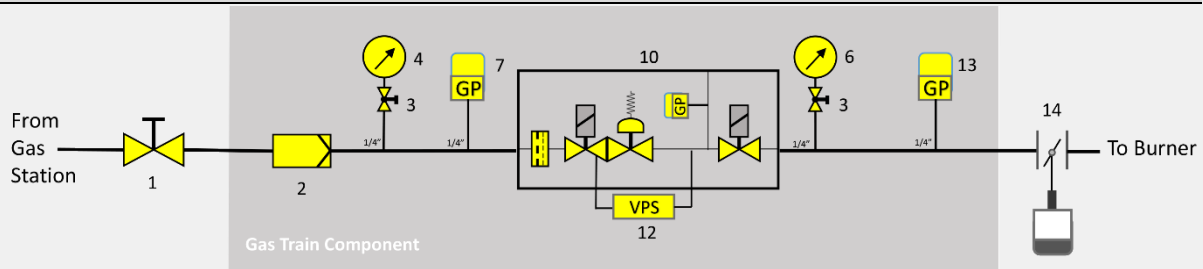

- |                                      |                                |                                   |
|--------------------------------------|--------------------------------|-----------------------------------|
| 1: Ball valve                        | 6: Pressure Gauge              | 11: Leak Test gas pressure switch |
| 2: Gas filter                        | 7: Min. gas pressure switch    | 12: Valve proving system          |
| 3: Ball valve                        | 8: Safety gas valve            | 13: Max. gas pressure switch      |
| 4: Pressure Gauge                    | 9: Main gas valve              | 14: Butterfly valve               |
| 5: Pressure regulator (Low pressure) | 10: Multi-Block Solenoid Valve |                                   |

## Gas train sizing

RGB-MS-Series...				
Burner	Gas Model	Gas Train Size	$\Delta P$ B.V (mbar)	$\Delta P$ C.H** (mbar)
RGB-MS-85/LN	GT1/GT2	Rp 1 ½	2	11.7
RGB-MS-110	GT1/GT2	Rp 1 ½	2	9
RGB-MS-130/LN*	GT3/GT4	Rp 1 ½	2	22.5
RGB-MS-145*	GT3/GT4	Rp 2	2	8.6
RGB-MS-175/LN	GT3/GT4	Rp 2	3	17
RGB-MS-185	GT3/GT4	Rp 2	3	14.5
RGB-MS-205	GT3/GT4	Rp 2	3	14.5
RGB-MS-255/LN	GT3/GT4	Rp 2	3	24.9
RGB-MS-305	GT3/GT4	DN 65	4	20.6
RGB-MS-385	GT3/GT4	DN 65	4	31.7
RGB-MS-405/LN	GT3/GT4	DN 65	4	47
RGB-MS-505/LN	GT3/GT4	DN 65	4	56
RGB-MS-605	GT3/GT4	DN 65	4	62.8

RLGB-MS-Series				
Burner	Gas Model	Gas Train Size	$\Delta P$ B.V (mbar)	$\Delta P$ C.H** (mbar)
RLGB-MS-110	GT1/GT2	Rp 1 ½	2	10
RLGB-MS-145*	GT3/GT4	Rp 2	2	13
RLGB-MS-175/LN*	GT3/GT4	Rp 2	3	17
RLGB-MS-205/LN	GT3/GT4	Rp 2	3	21.5
RLGB-MS-255	GT3/GT4	Rp 2	4	27.8
RLGB-MS-305/LN	GT3/GT4	DN 65	4	23
RLGB-MS-385/LN	GT3/GT4	DN 65	4	27.3
RLGB-MS-405/LN	GT3/GT4	DN 65	4	44
RLGB-MS-505/LN	GT3/GT4	DN 65	4	47
RLGB-MS-605/LN	GT3/GT4	DN 65	4	68

\*Max. gas pressure switch is optional

\*\*Combustion Head

# Emission

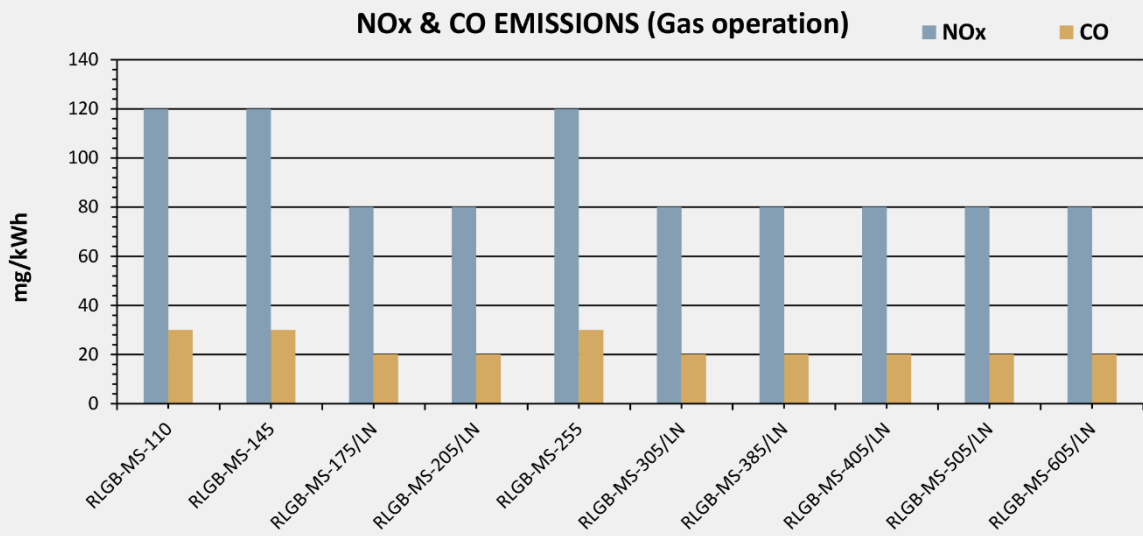
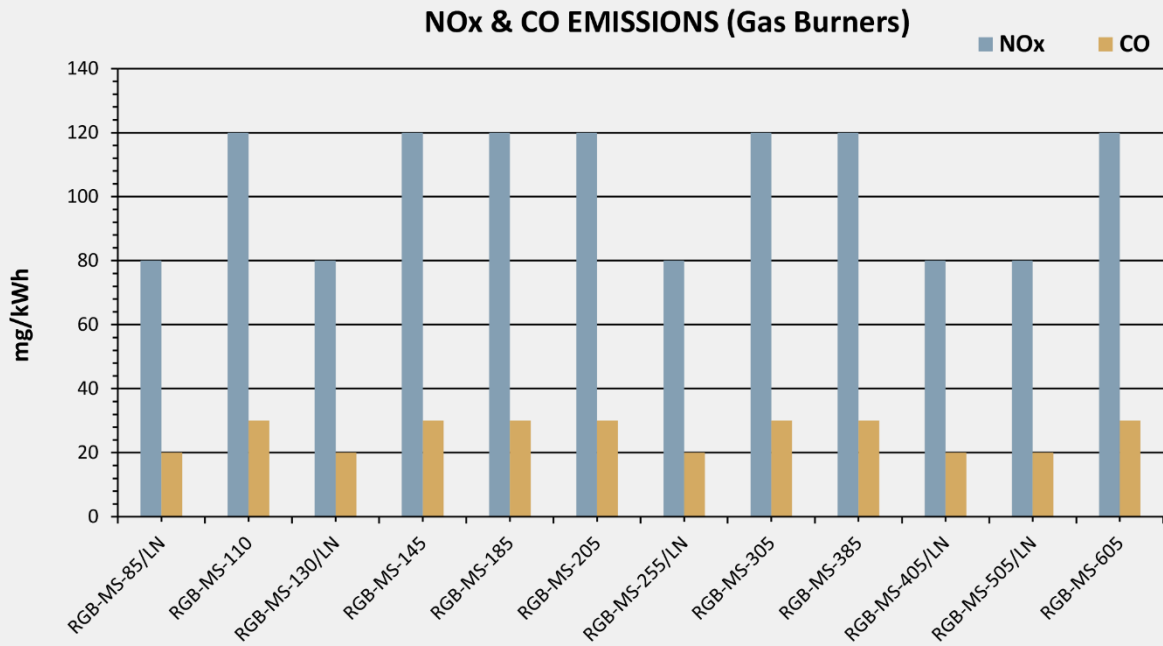



### NOx & CO EMISSIONS (Oil operation)

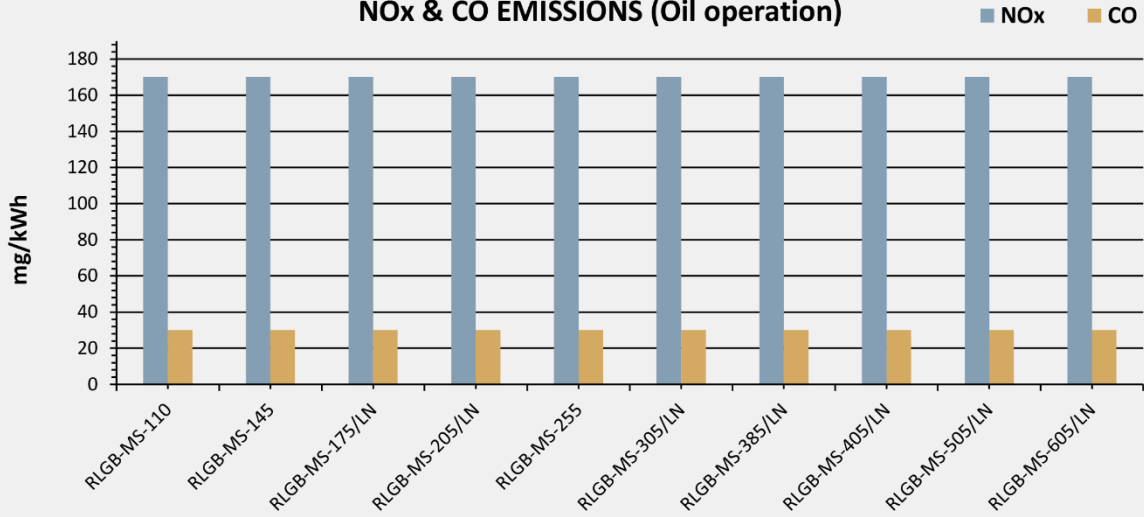

### Noise Level (RGB-MS Series)

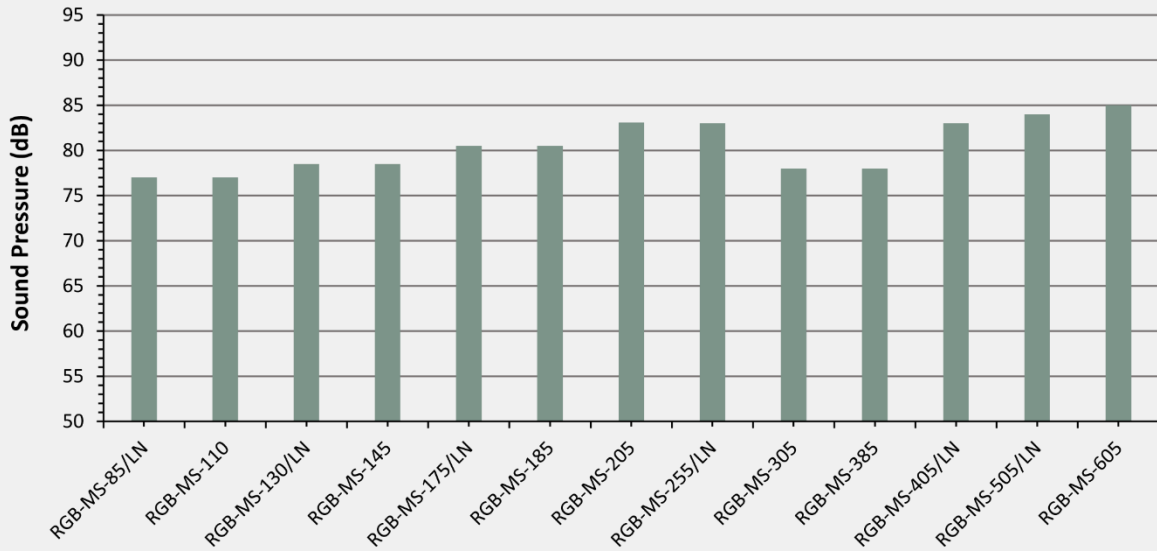

### Noise Level (RLGB-MS Series)

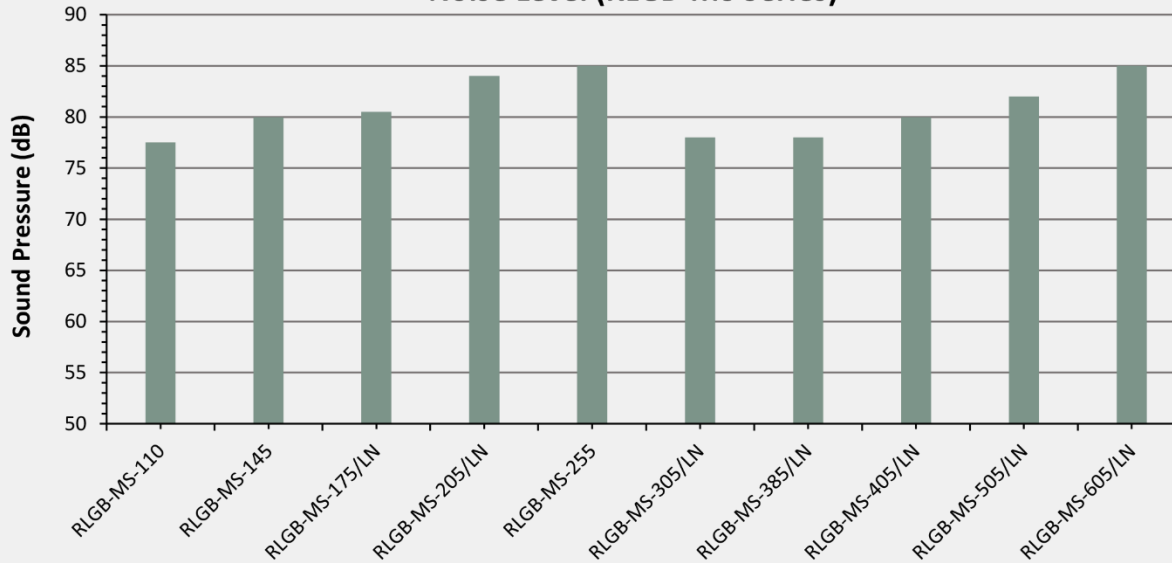



The beauty of colors!

# Mechanical Modular Mono Block Burners

Heat Rated Output: 300-6200 kW



- SMILE INTO THE FUTURE -

[www.raadmanburner.com](http://www.raadmanburner.com)



# raadman Mechanical modular burners

RGB-MC series of raadman burners cover a firing range of 1000 to 6200 kW, and they are manufactured with high-quality electro-mechanical accessories with easy installation and commissioning. They are mechanically resistant and economically designed for domestic or industrial applications such as three pass hot water boilers, steam boilers, hot air generators, etc.

Their operation is “two-stage” at the oil side and “modulating” at the gas side by installing a PID logic regulator and respective probes. The customers should kindly note that the PID regulator is not included in the burners routine process and needs to be ordered separately.

RGB-MC series burners guarantee high-efficiency levels in all the various applications, thus there will be a reduction in fuel consumption and running costs. Optimization of sound emissions is guaranteed by special design of the air suction circuit and using of soundproofing material. The exclusive design ensures the reduced dimensions, simple use and maintenance. A wide range of accessories guarantees elevated working flexibility.

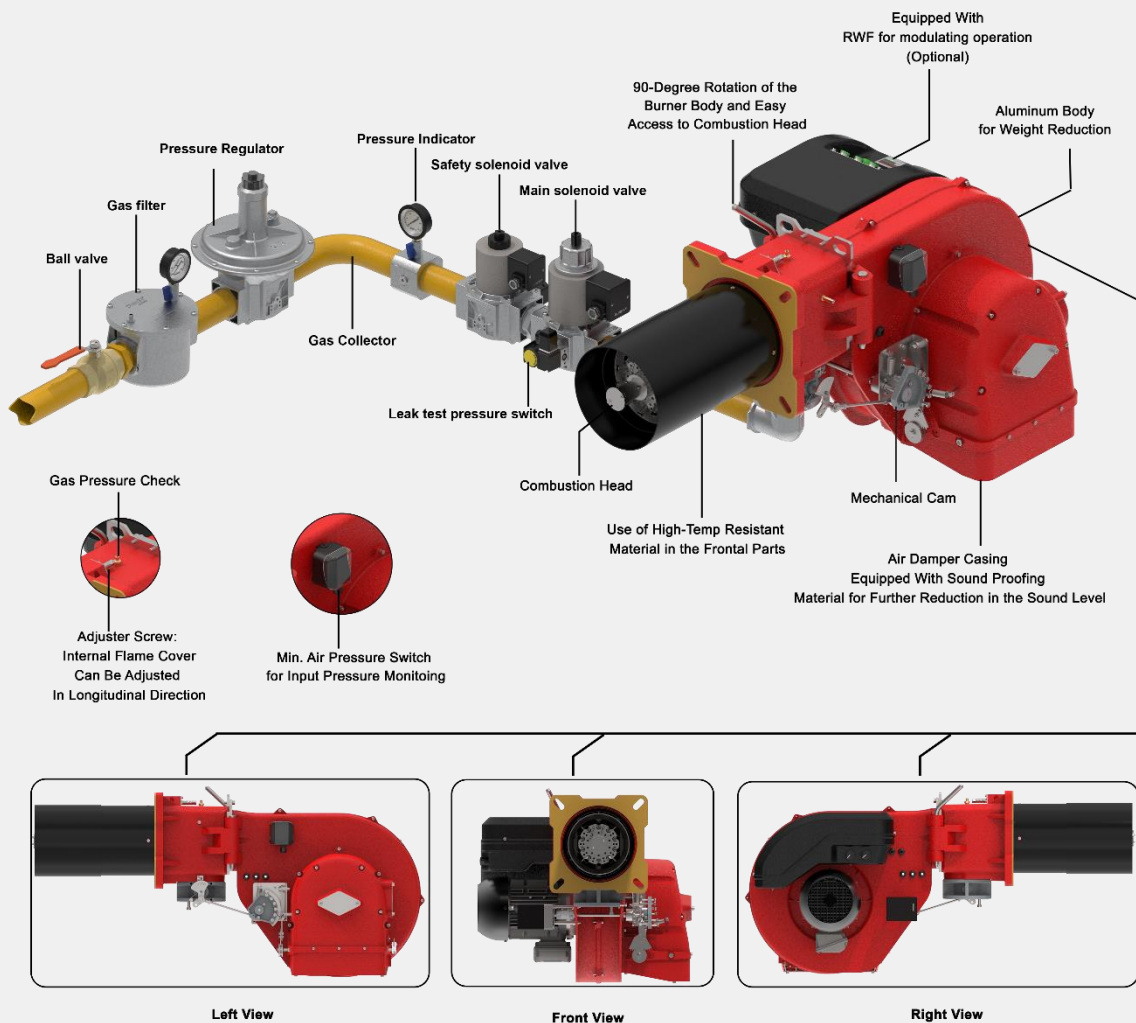

# Burner management system overview

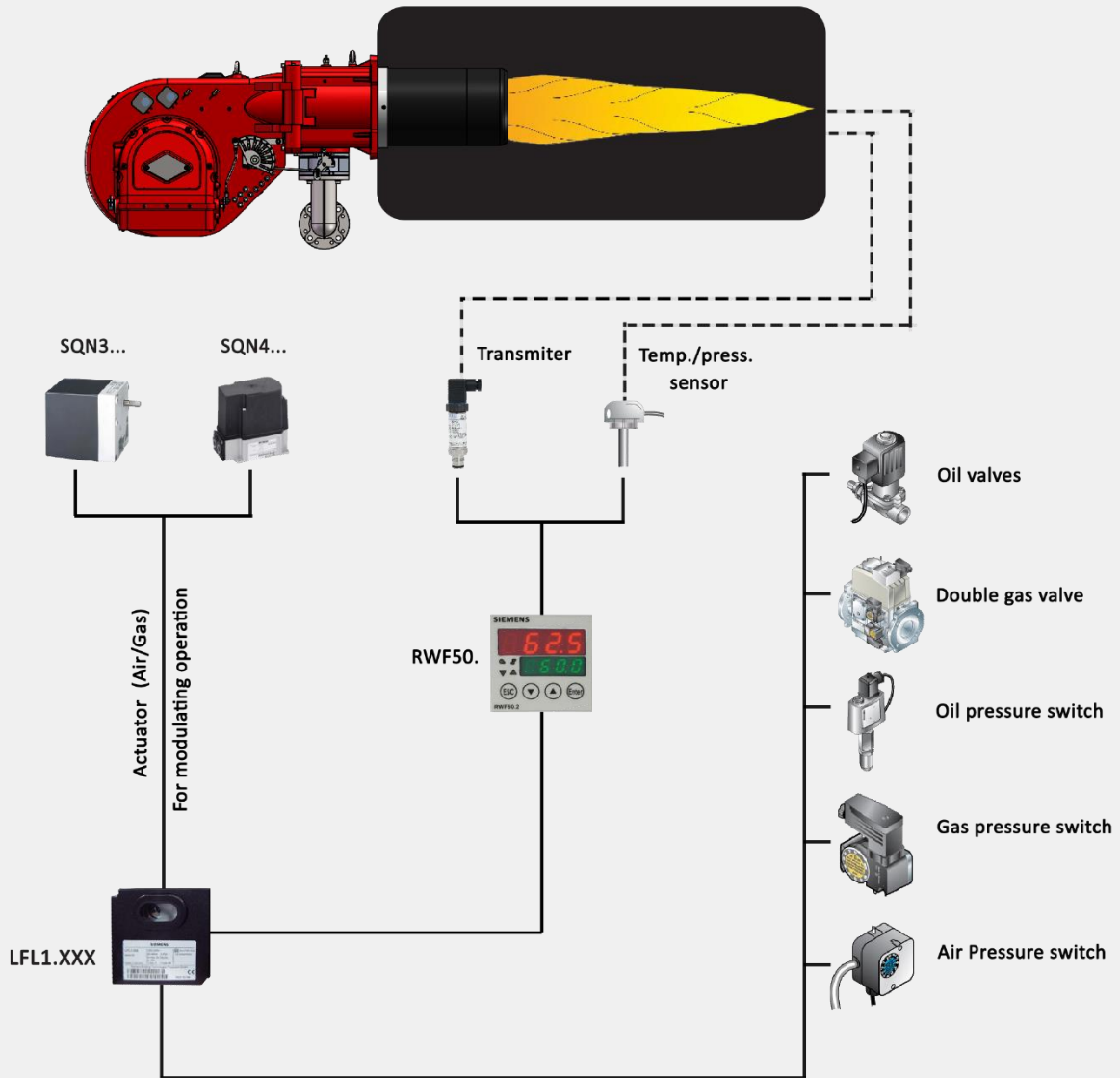

To obtain modulating operation, the RGB-MC series of burners require a regulator with three-point outlet controls. The following lists the accessories required for the mechanical modulating operation.

- RWF50
- Temperature sensor
- Actuator modulating operation

# raadman RGB-MC series burner

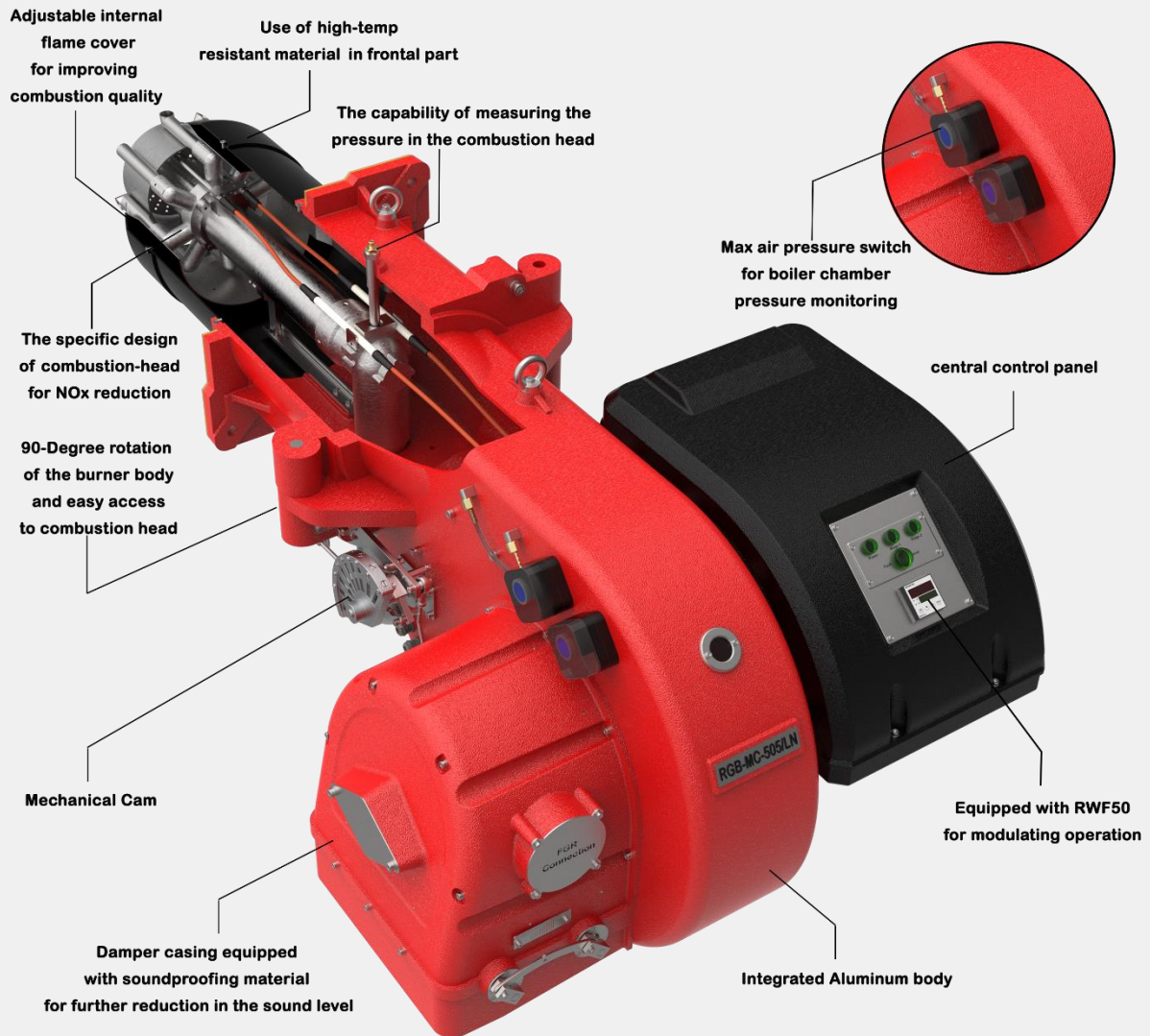





# Burner selection: capacity and working diagram

## Gas Burner

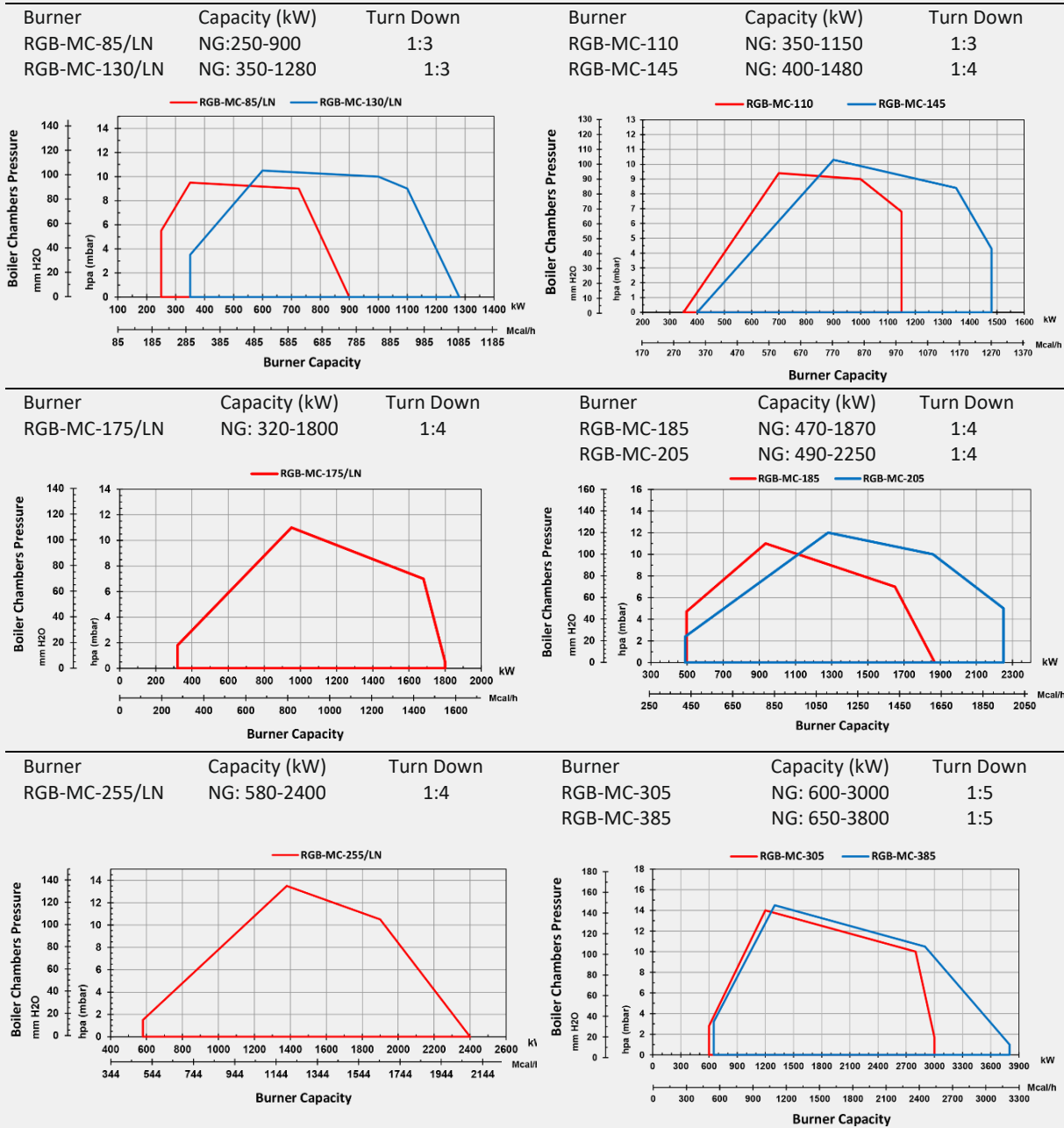

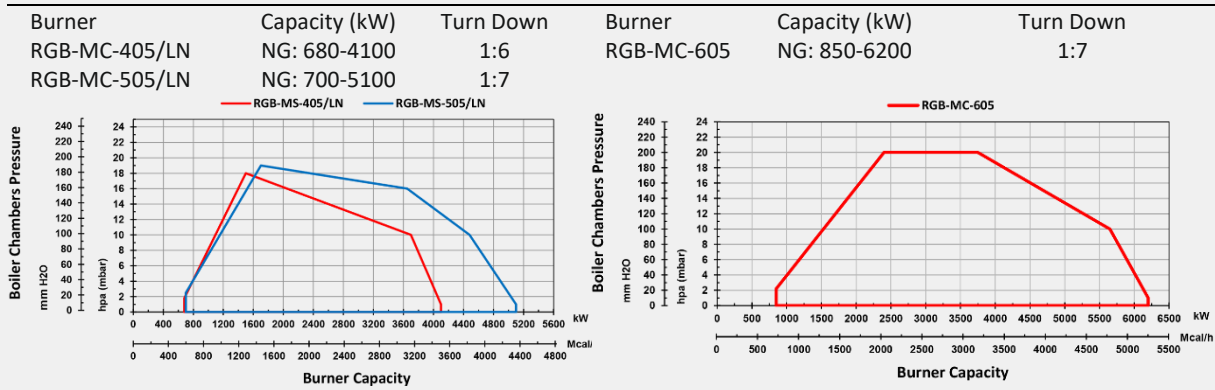

About the working diagram Working diagram for gas burner is certified in accordance with EN 676. The firing rate diagram has been obtained considering ambient temperature of 20°C and atmospheric pressure of 1013 mbar (Sea level condition). For installation at higher altitudes, a reduction in capacity of 1% per 100 m above sea level should be taken into account.

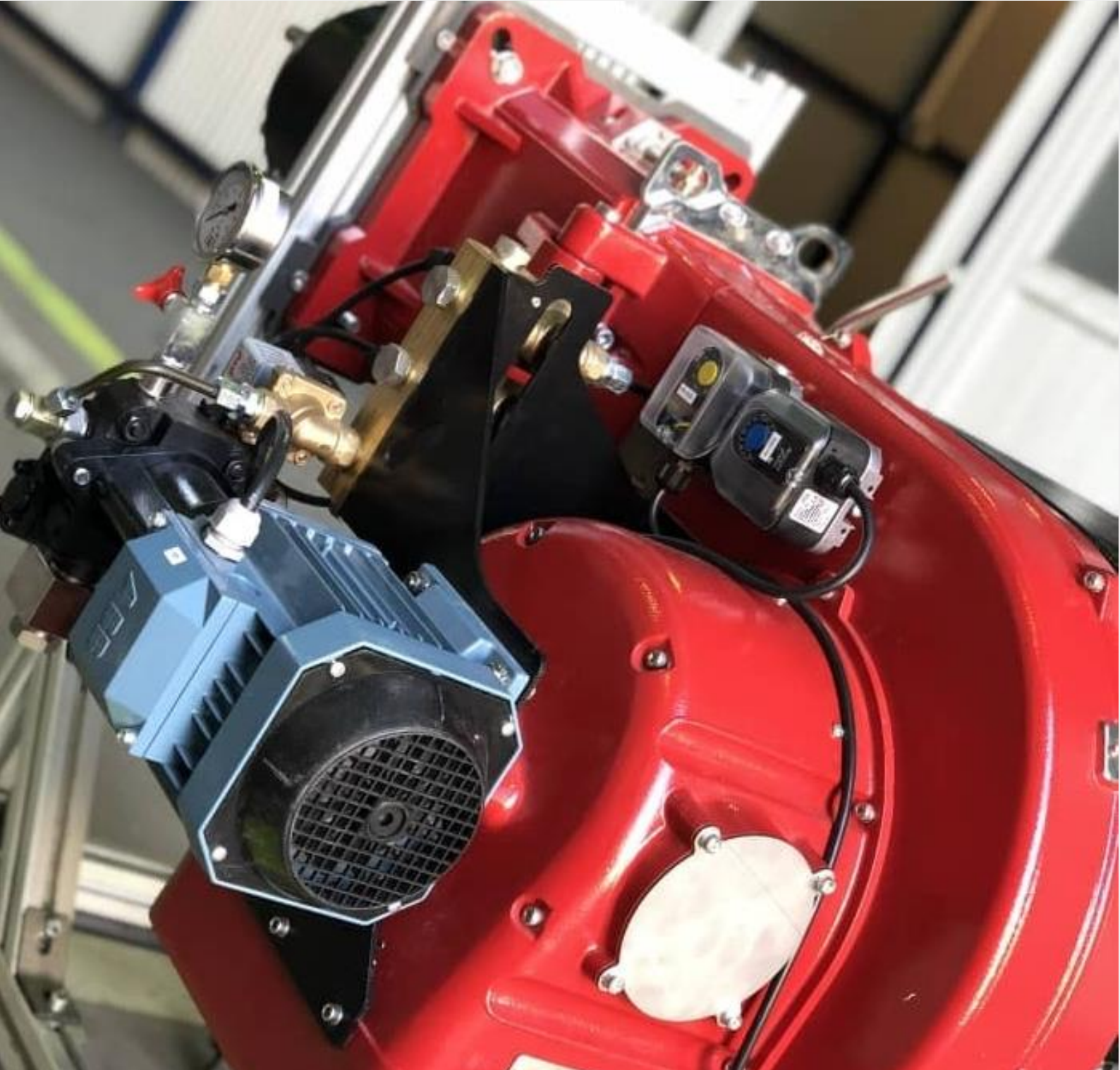

# General dimension: RGB-MC series

## RGB-MC-85/LN, RGB-MC-130/LN

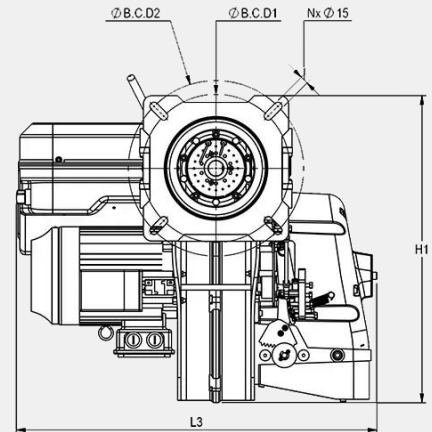
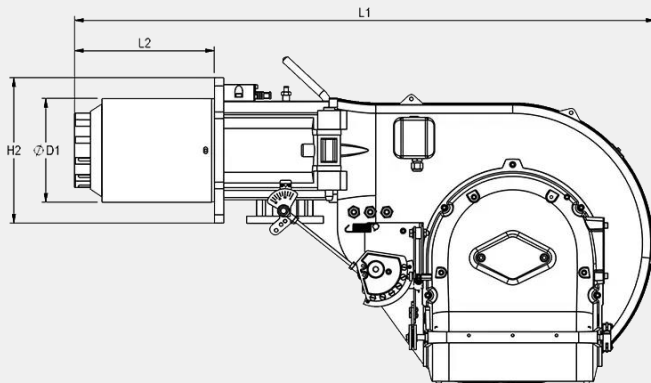

Burner Type	L <sub>1</sub>	L <sub>2</sub>	L <sub>3</sub>	H <sub>1</sub>	H <sub>2</sub>	D <sub>1</sub>	D <sub>2</sub>	N	B.C.D.1	B.C.D.2
RGB-MC-85/LN	1068	255	641	600	265	193	15	4	270	320
RGB-MC-130/LN	1072	260	641	600	265	193	15	4	270	320

## RGB-MC-110, RGB-MC-145

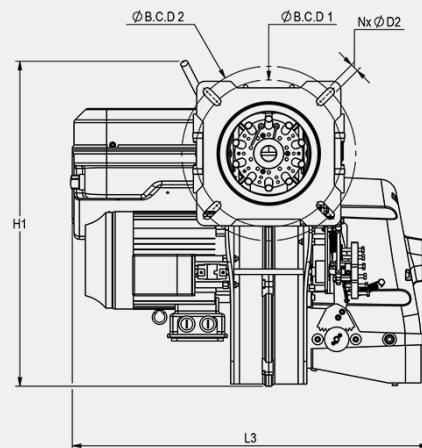
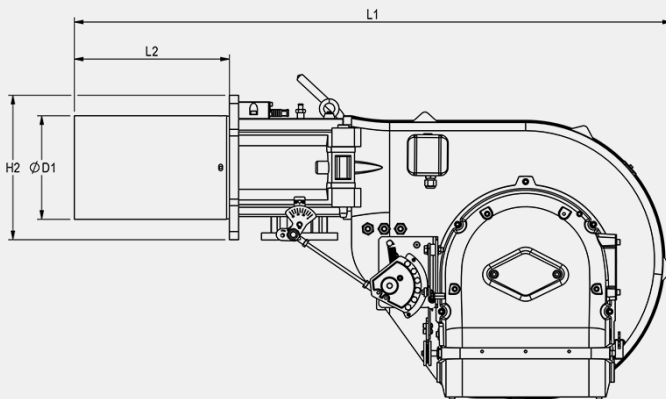

Burner Type	L <sub>1</sub>	L <sub>2</sub>	L <sub>3</sub>	H <sub>1</sub>	H <sub>2</sub>	D <sub>1</sub>	D <sub>2</sub>	N	B.C.D.1	B.C.D.2
RGB-MC-110	1066	254	643	600	265	184	15	4	270	320
RGB-MC-145	1097	285	643	600	265	194	15	4	270	320



### RGB-MC-175/LN

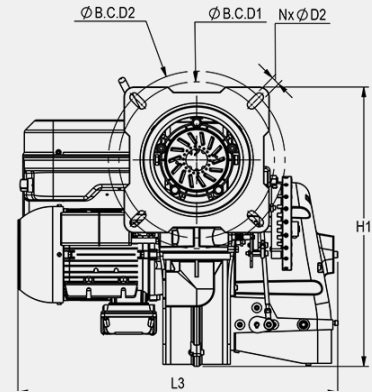
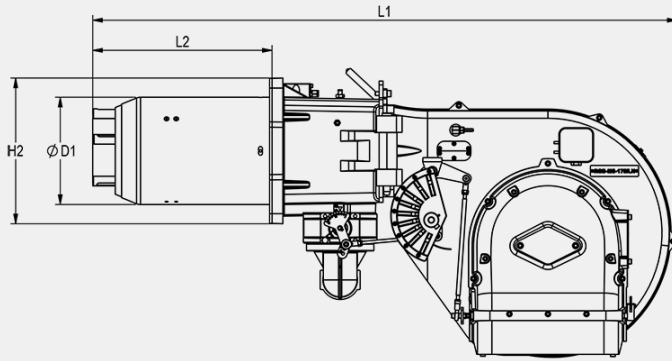

Burner Type	L <sub>1</sub>	L <sub>2</sub>	L <sub>3</sub>	H <sub>1</sub>	H <sub>2</sub>	D <sub>1</sub>	D <sub>2</sub>	N	B.C.D.1	B.C.D.1
RGB-MC-175/LN	1213	373	665	598	302	226	18	4	323	367

### RGB-MC-185, RGB-MC-205

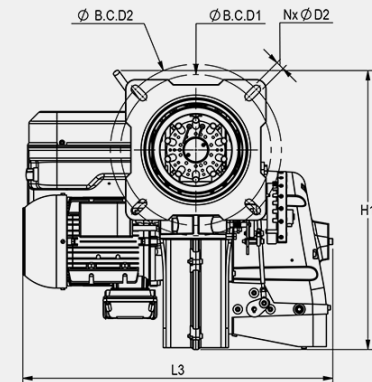
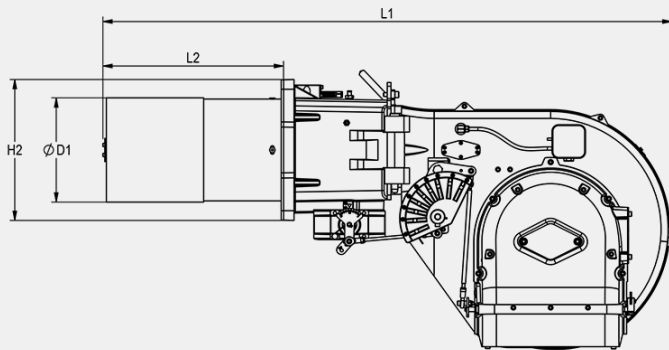

Burner Type	L <sub>1</sub>	L <sub>2</sub>	L <sub>3</sub>	H <sub>1</sub>	H <sub>2</sub>	D <sub>1</sub>	D <sub>2</sub>	N	B.C.D.1	B.C.D.1
RGB-MC-185	1229	388	666	598	302	223	18	4	323	367
RGB-MC-205	1229	388	666	598	302	223	18	4	323	367

### RGB-MC-255/LN

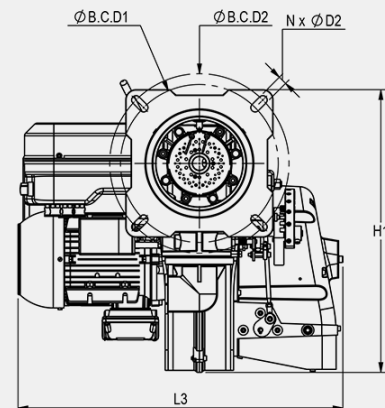
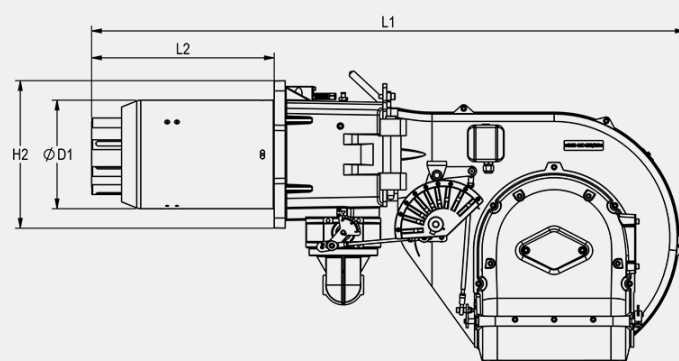

Burner Type	L <sub>1</sub>	L <sub>2</sub>	L <sub>3</sub>	H <sub>1</sub>	H <sub>2</sub>	D <sub>1</sub>	D <sub>2</sub>	N	B.C.D.1	B.C.D.2
RGB-MC-255/LN	1214	374	762	598	302	226	18	4	323	368

### RGB-MC-305, RGB-MC-385

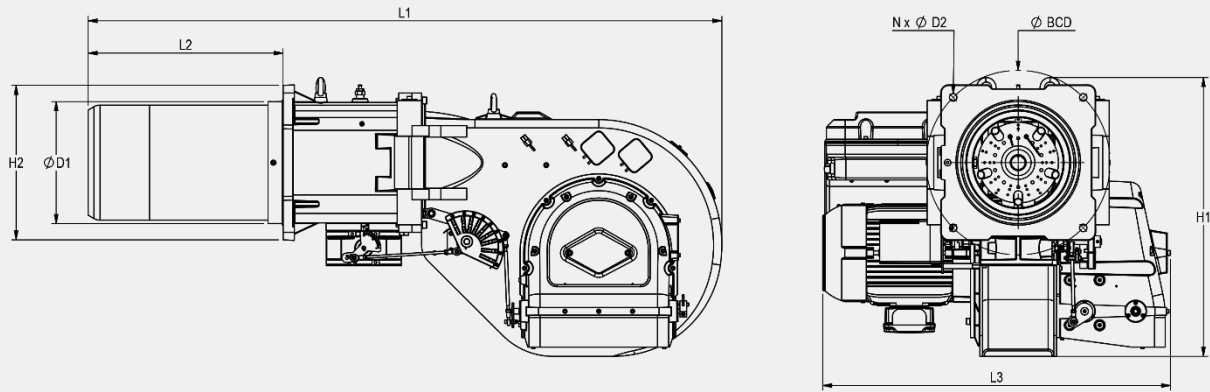

Burner Type	L <sub>1</sub>	L <sub>2</sub>	L <sub>3</sub>	H <sub>1</sub>	H <sub>2</sub>	D <sub>1</sub>	D <sub>2</sub>	N	B.C. D
RGB-MC-305	1689	520	927	741	413	328	20	4	490
RGB-MC-385	1689	520	927	741	413	328	20	4	490

### RGB-MS-405/LN, RGB-MS-505/LN

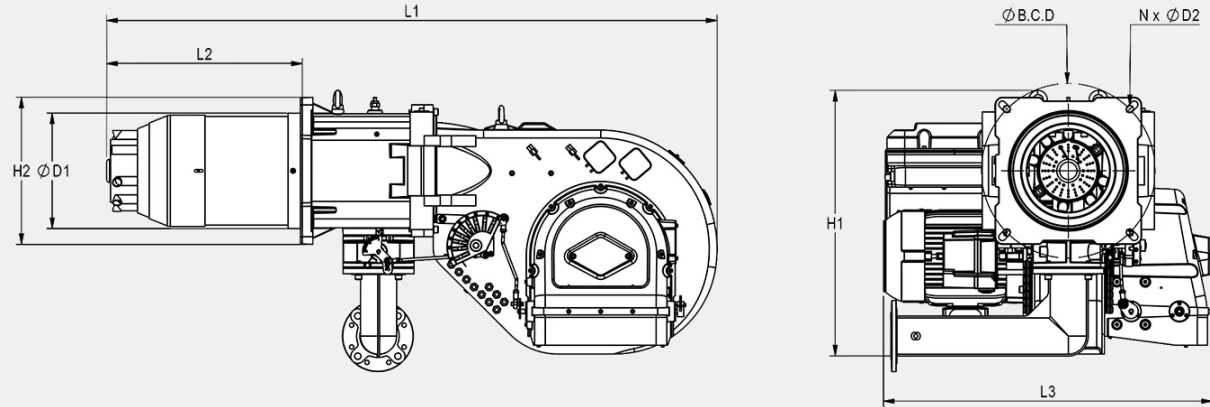

Burner Type	L <sub>1</sub>	L <sub>2</sub>	L <sub>3</sub>	H <sub>1</sub>	H <sub>2</sub>	D <sub>1</sub>	D <sub>2</sub>	N	B.C. D
RGB-MC-405/LN	1721	552	930	798	413	328	20	4	490
RGB-MC-505/LN	1721	552	930	798	413	328	20	4	490

### RGB-MS-605

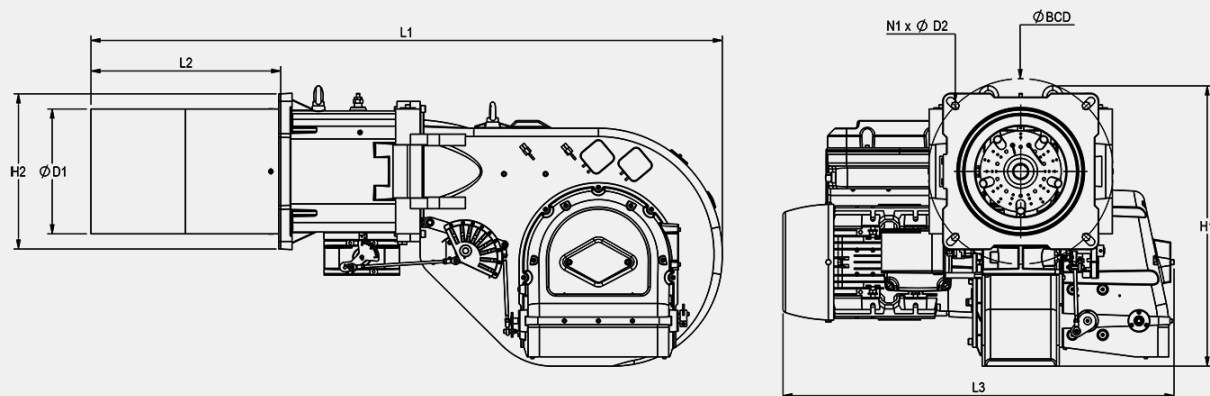

Burner Type	L <sub>1</sub>	L <sub>2</sub>	L <sub>3</sub>	H <sub>1</sub>	H <sub>2</sub>	D <sub>1</sub>	D <sub>2</sub>	N	B.C. D
RGB-MC-605	1665	502	1035	741	410	336	20	4	490

## Technical data: RGB-MC series

RGB-MC series of raadman burners include ventilation system with AC motor, ignition transformer, and electrodes, electrical panel with power contactors, fuses, relays, central controller, air pressure switches, soundproofing material, Lamp signals for operational supervision, etc.

- N.G operation: Mechanical Modular

Burner	Power system		Power management system	
	Motor(kW/PH/V/HZ/rpm)		Controller	Actuator (N.M)
RGB-MC-85/LN	1.5 /3 /380-400 /50 /2840		Siemens	3
RGB-MC-110	1.5 /3 /380-400 /50 /2840		Siemens	3
RGB-MC-130/LN	2.2 /3 /380-400 /50 /2840		Siemens	3
RGB-MC-145	2.2 /3 /380-400 /50 /2840		Siemens	3
RGB-MC-175/LN	4 /3 /380-400 /50 /2840		Siemens	3
RGB-MC-185	5.5 /3 /380-400 /50 /2840		Siemens	3
RGB-MC-205	5.5 /3 /380-400 /50 /2840		Siemens	3
RGB-MC-255/LN	5.5 /3 /380-400 /50 /2840		Siemens	3
RGB-MC-305	7.5 /3 /380-400 /50 /2900		Siemens	10
RGB-MC-385	7.5 /3 /380-400 /50 /2900		Siemens	10
RGB-MC-405/LN	11 /3 /380-400 /50 /2900		Siemens	10
RGB-MC-505/LN	11 /3 /380-400 /50 /2900		Siemens	10
RGB-MC-605	15 /3 /380-400 /50 /2900		Siemens	10





# raadman RLGB-MC series burner

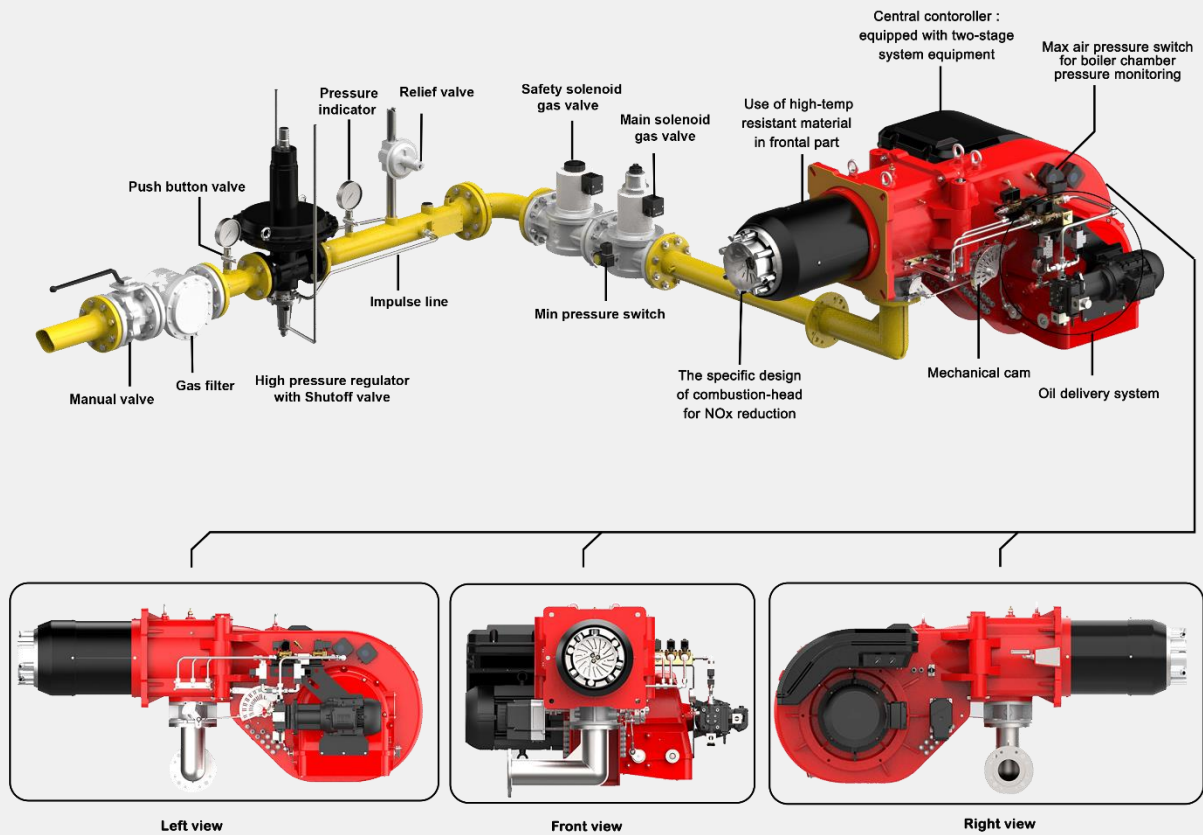



- raadman -



# Burner selection: capacity and working diagram

## Dual-fuel Burner

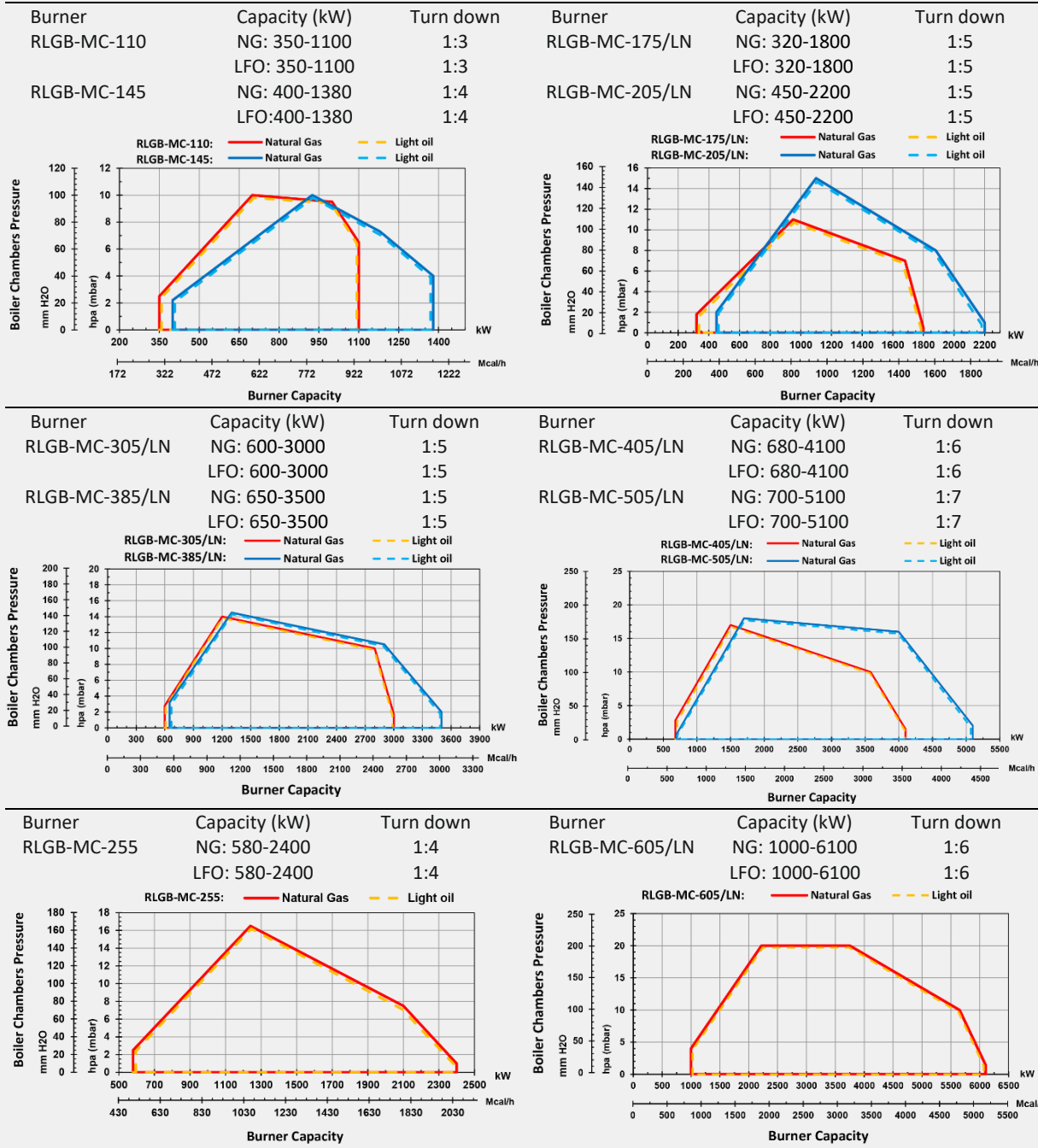

About the working diagram:

The working diagrams for natural gas and light fuel oil are certified in accordance with BS-EN 676 and BS-EN 267, respectively.

The firing rate diagram has been obtained considering the ambient temperature of 20°C and atmospheric pressure of 1013 mbar (Sea level condition).



# General dimension: RLGB-MC series

## RLGB-MC-110, RLGB-MC-145

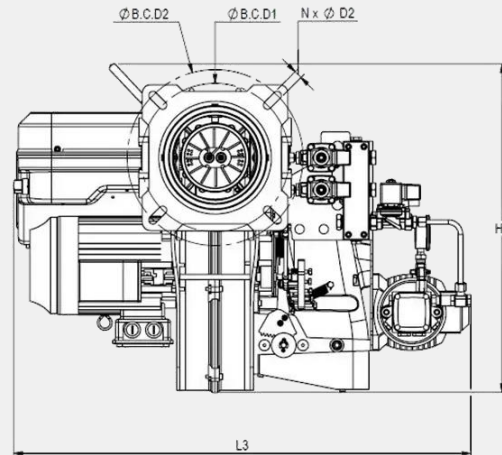
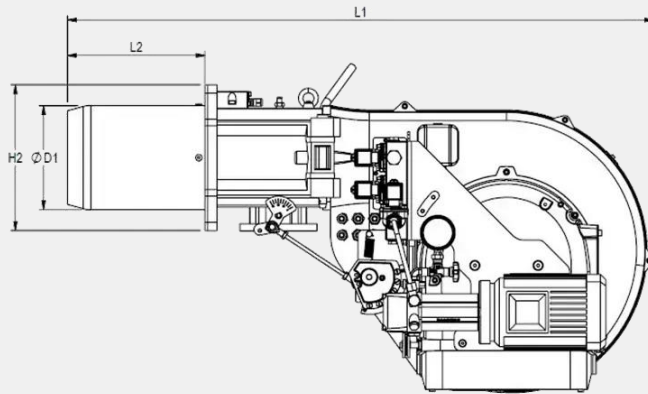

Burner Type	L <sub>1</sub>	L <sub>2</sub>	L <sub>3</sub>	H <sub>1</sub>	H <sub>2</sub>	D <sub>1</sub>	D <sub>2</sub>	N	B.C. D1	B.C. D2
RLGB-MC-110	1068	255	830	598	265	184	15	4	270	320
RLGB-MC-145	1068	255	830	598	265	194	15	4	270	320

## RLGB-MC-175/LN, RLGB-MC-205/LN

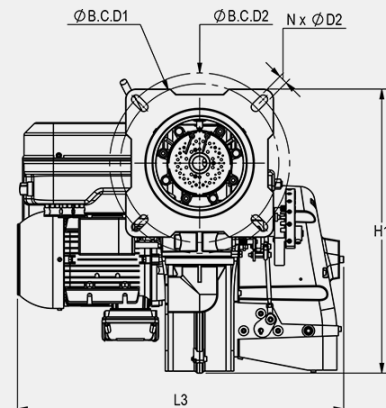
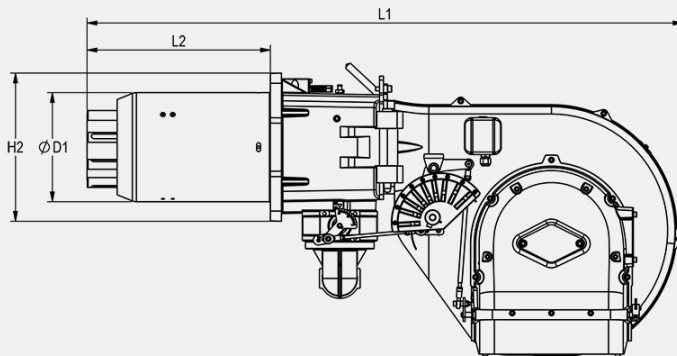

Burner Type	L <sub>1</sub>	L <sub>2</sub>	L <sub>3</sub>	H <sub>1</sub>	H <sub>2</sub>	D <sub>1</sub>	D <sub>2</sub>	N	B.C. D1	B.C. D2
RLGB-MC-175/LN	1213	373	875	598	300	226	18	4	323	367
RLGB-MC-205/LN	1213	373	875	598	300	226	18	4	323	367

### RLGB-MC-255

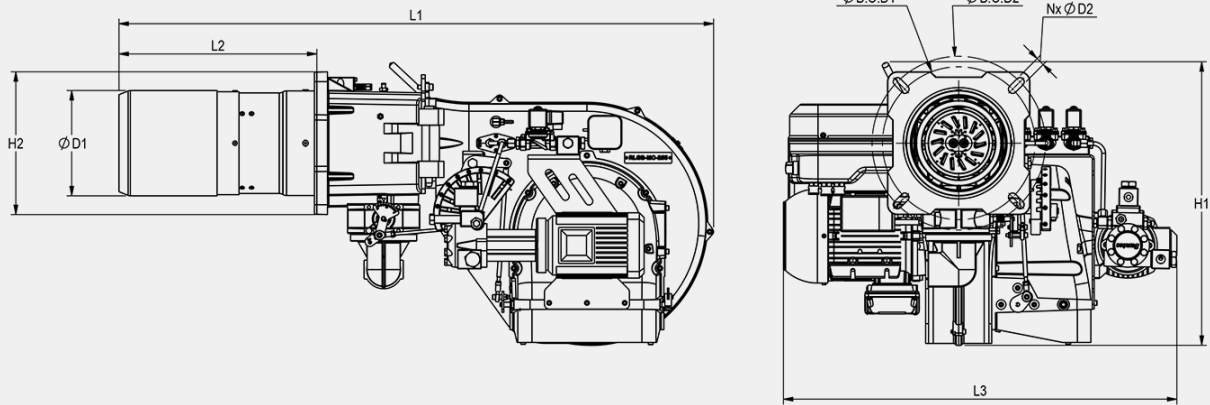

Burner Type	L <sub>1</sub>	L <sub>2</sub>	L <sub>3</sub>	H <sub>1</sub>	H <sub>2</sub>	D <sub>1</sub>	D <sub>2</sub>	N	B.C. D1	B.C. D2
RLGB-MC-255	1260	419	833	598	300	223	18	4	323	367

### RLGB-MC-305/LN, RLGB-MC-385/LN, RLGB-MC-405/LN, RLGB-MC-505/LN, RLGB-MC-605/LN

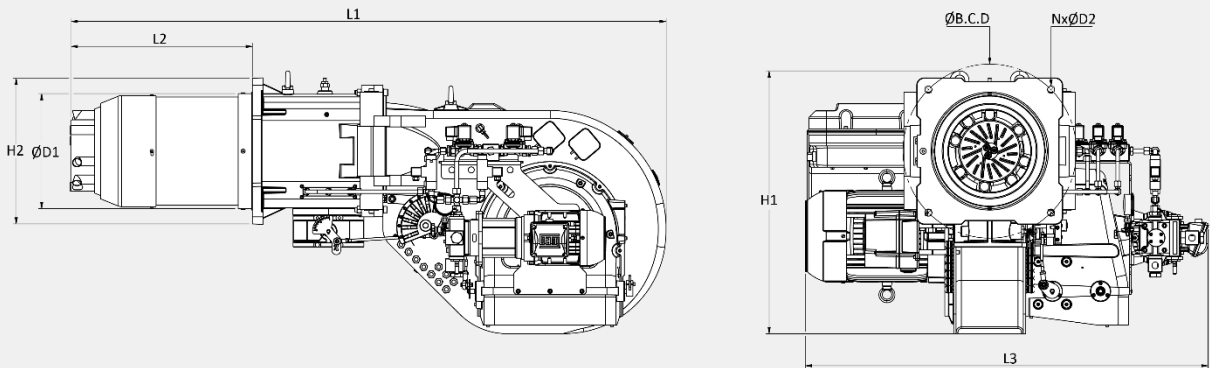

Burner Type	L <sub>1</sub>	L <sub>2</sub>	L <sub>3</sub>	H <sub>1</sub>	H <sub>2</sub>	D <sub>1</sub>	D <sub>2</sub>	N	B.C. D
RLGB-MC-305/LN	1683	514	1137	741	410	328	20	4	490
RLGB-MC-385/LN	1683	514	1137	741	410	328	20	4	490
RLGB-MC-405/LN	1683	514	1249	741	410	328	20	4	490
RLGB-MC-505/LN	1683	514	1249	741	410	328	20	4	490
RLGB-MC-605/LN	1680	512	1245	741	410	340	20	4	490

## Technical data: RLGB-MC series

- N.G operation: Mechanical Modular
- LFO operation: II or III Stages

Burner	Power system		Power management system	
	Motor(kW/PH/V/HZ/rpm)		Controller	Actuator (N.M)
RLGB-MC-110	1.5 /3 /380-400 /50 /2840		Siemens	3
RLGB-MC-145	2.2 /3 /380-400 /50 /2840		Siemens	3
RLGB-MC-175/LN	4 /3 /380-400 /50 /2840		Siemens	3
RLGB-MC-205/LN	5.5 /3 /380-400 /50 /2840		Siemens	3
RLGB-MC-255	5.5 /3 /380-400 /50 /2840		Siemens	3
RLGB-MC-305/LN	7.5 /3 /380-400 /50 /2940		Siemens	10
RLGB-MC-385/LN	7.5 /3 /380-400 /50 /2940		Siemens	10
RLGB-MC-405/LN	11 /3 /380-400 /50 /2940		Siemens	10
RLGB-MC-505/LN	11 /3 /380-400 /50 /2940		Siemens	10
RLGB-MC-605/LN	15 /3 /380-400 /50 /2940		Siemens	10

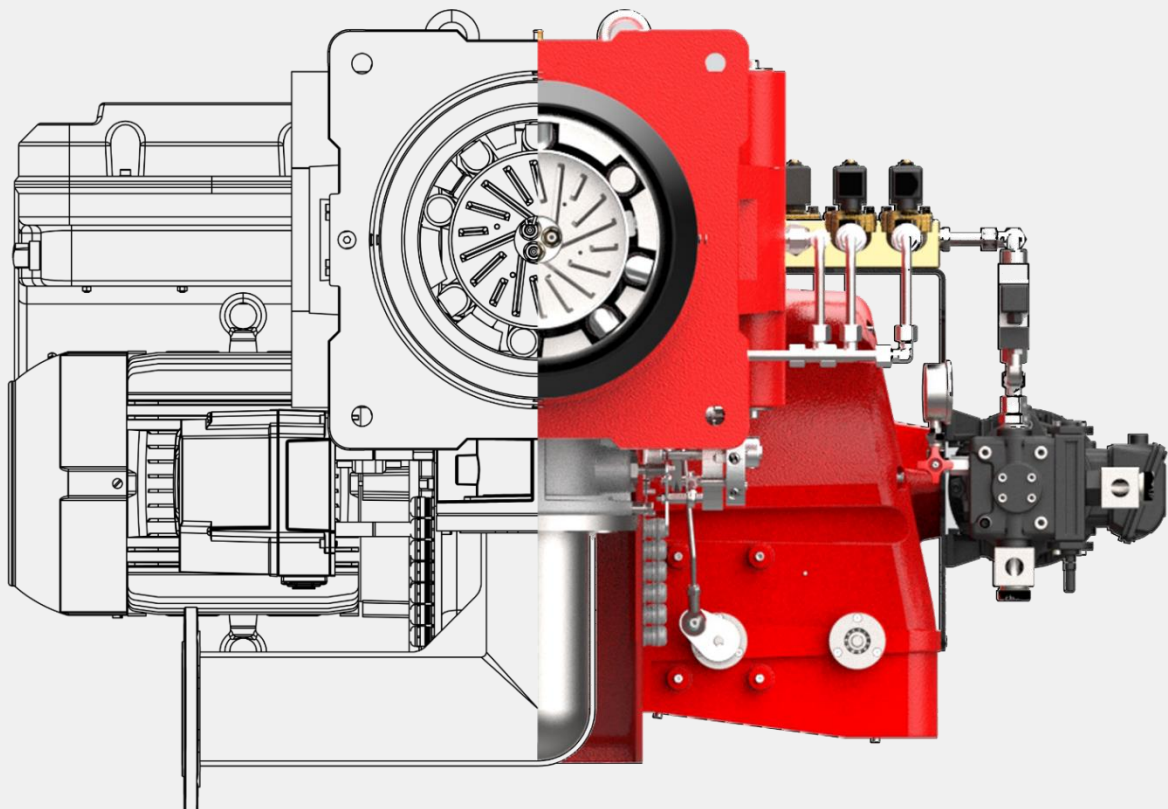





# Gas train diagram

**GT1** (Pressure input < 360 mbar, separated items)

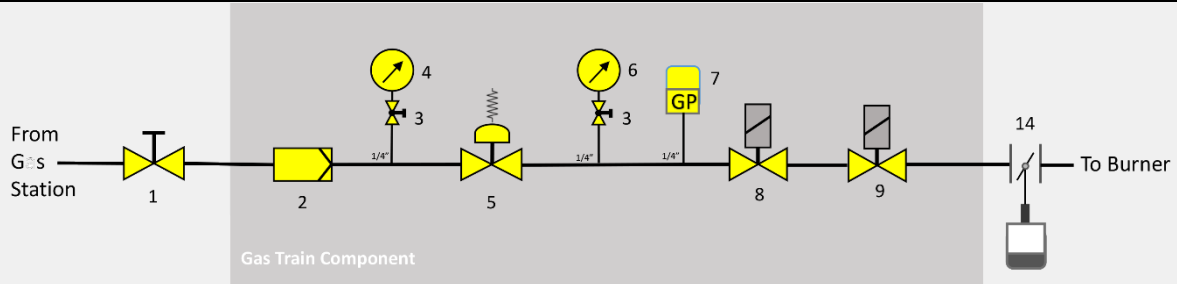

**GT2** (Pressure input < 360 mbar, multi bloc gas train)

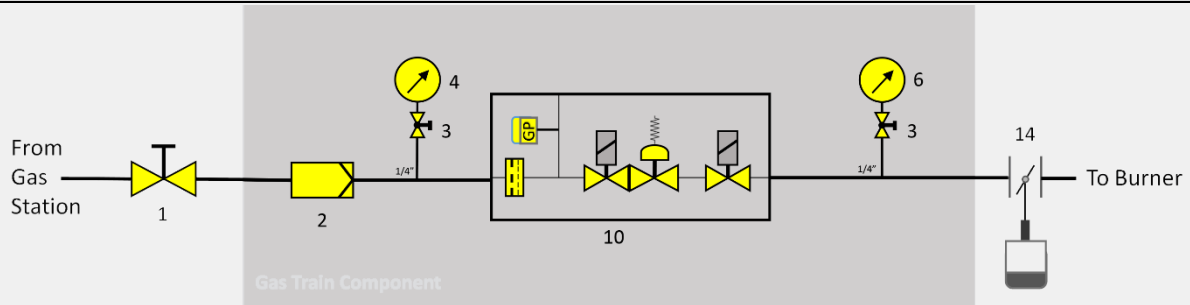

**GT3** (Pressure input < 360 mbar, separated items, with valve proving system)

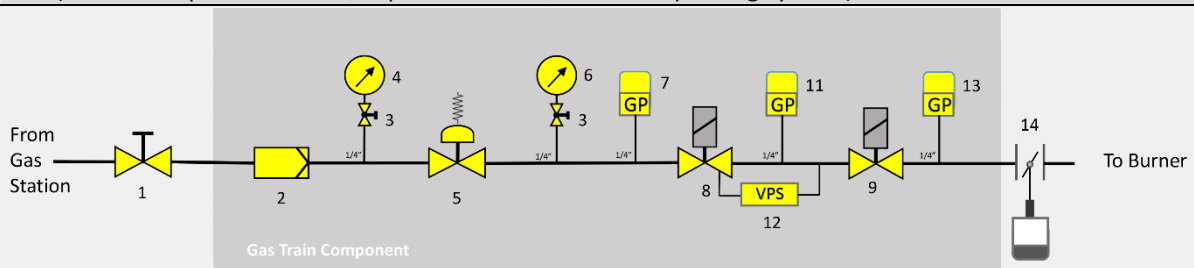

**GT4** (Pressure input < 360 mbar, multi bloc gas train, with valve proving system)

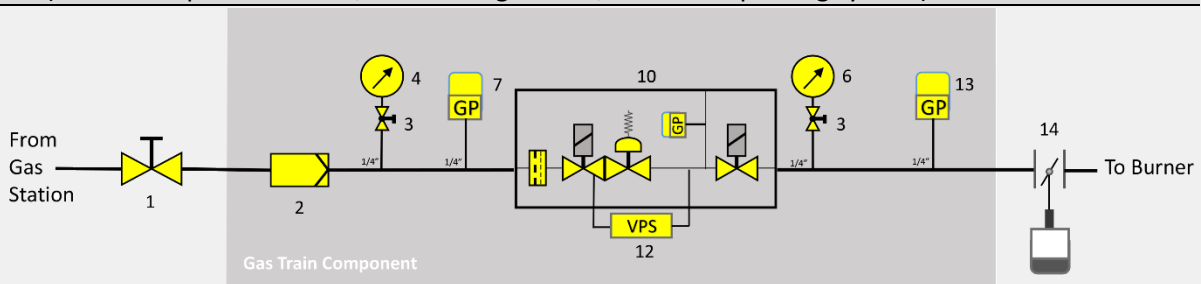

- |                                      |                                |                                   |
|--------------------------------------|--------------------------------|-----------------------------------|
| 1: Ball valve                        | 6: Pressure Gauge              | 11: Leak Test gas pressure switch |
| 2: Gas filter                        | 7: Min. gas pressure switch    | 12: Valve proving system          |
| 3: Ball valve                        | 8: Safety gas valve            | 13: Max. gas pressure switch      |
| 4: Pressure Gauge                    | 9: Main gas valve              | 14: Butterfly valve               |
| 5: Pressure regulator (Low pressure) | 10: Multi-Block Solenoid Valve |                                   |

## Gas train sizing

RGB-MC-Series...				
Burner	Gas Model	Gas Train Size	$\Delta P$ B.V (mbar)	$\Delta P$ C.H** (mbar)
RGB-MC-85/LN	GT1/GT2	Rp 1 ½	2	11.7
RGB-MC-110	GT1/GT2	Rp 1 ½	2	9
RGB-MC-130/LN*	GT3/GT4	Rp 1 ½	2	22.5
RGB-MC-145*	GT3/GT4	Rp 2	2	8.6
RGB-MC-175/LN	GT3/GT4	Rp 2	3	17
RGB-MC-185	GT3/GT4	Rp 2	3	14.5
RGB-MC-205	GT3/GT4	Rp 2	3	14.5
RGB-MC-255/LN	GT3/GT4	Rp 2	3	24.9
RGB-MC-305	GT3/GT4	DN 65	4	20.6
RGB-MC-385	GT3/GT4	DN 65	4	31.7
RGB-MC-405/LN	GT3/GT4	DN 65	4	47
RGB-MC-505/LN	GT3/GT4	DN 65	4	56
RGB-MC-605	GT3/GT4	DN 65	4	62.8

RLGB-MC-Series				
Burner	Gas Model	Gas Train Size	$\Delta P$ B.V (mbar)	$\Delta P$ C.H** (mbar)
RLGB-MC-110	GT1/GT2	Rp 1 ½	2	10
RLGB-MC-145*	GT3/GT4	Rp 2	2	13
RLGB-MC-175/LN*	GT3/GT4	Rp 2	3	17
RLGB-MC-205/LN	GT3/GT4	Rp 2	3	21.5
RLGB-MC-255	GT3/GT4	Rp 2	4	27.8
RLGB-MC-305/LN	GT3/GT4	DN 65	4	23
RLGB-MC-385/LN	GT3/GT4	DN 65	4	27.3
RLGB-MC-405/LN	GT3/GT4	DN 65	4	44
RLGB-MC-505/LN	GT3/GT4	DN 65	4	47
RLGB-MC-605/LN	GT3/GT4	DN 65	4	68

\*Max. gas pressure switch is optional

\*\*Combustion Head



# Emission

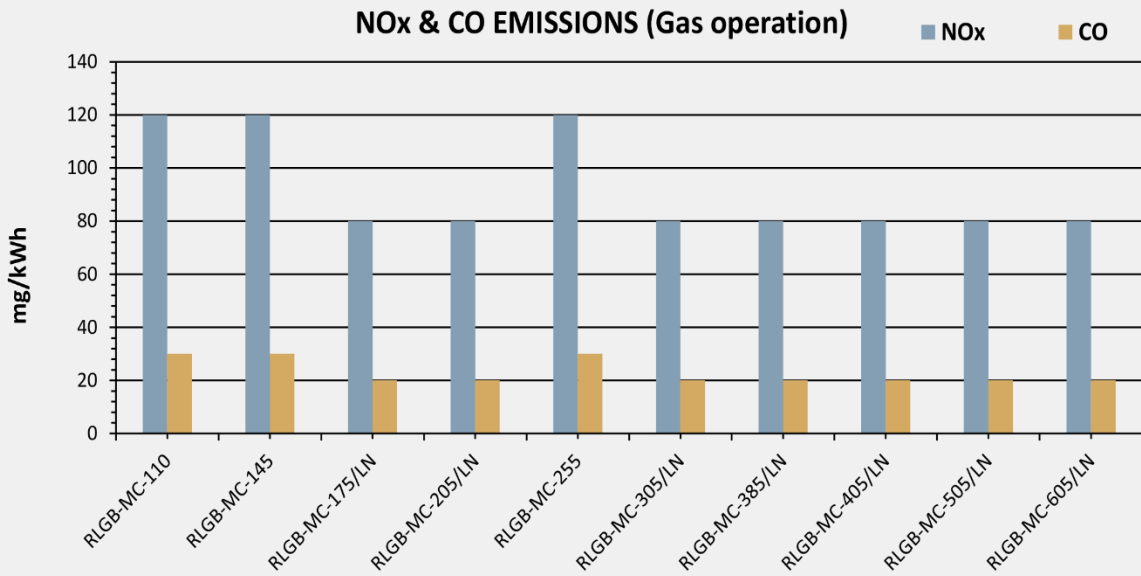
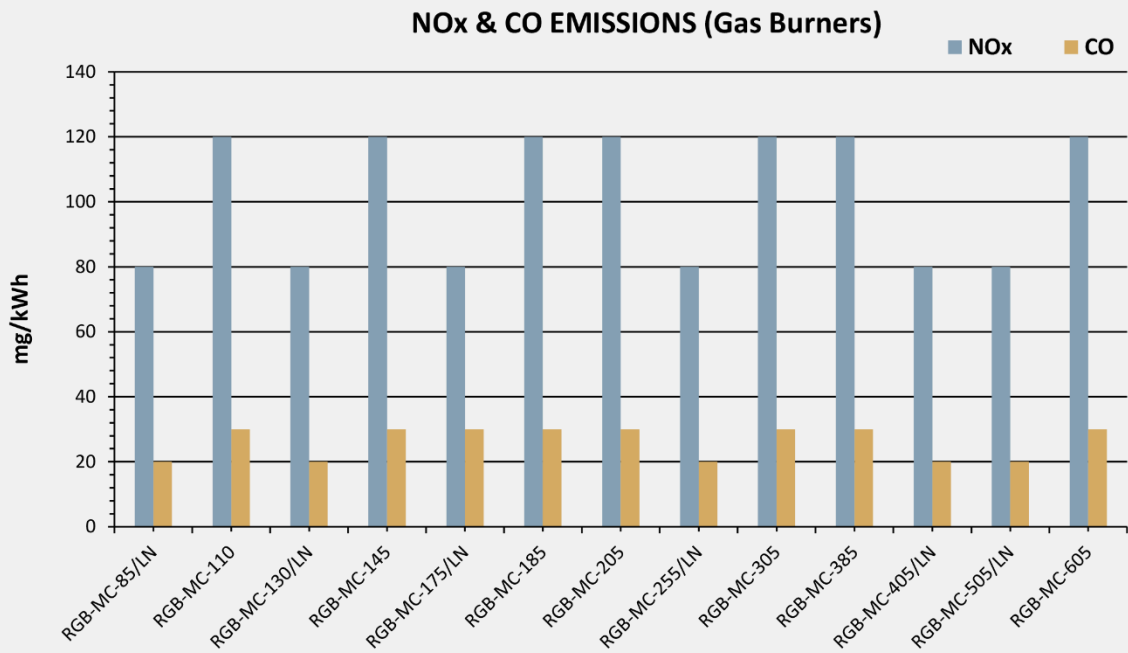

### NOx & CO EMISSIONS (Oil operation)

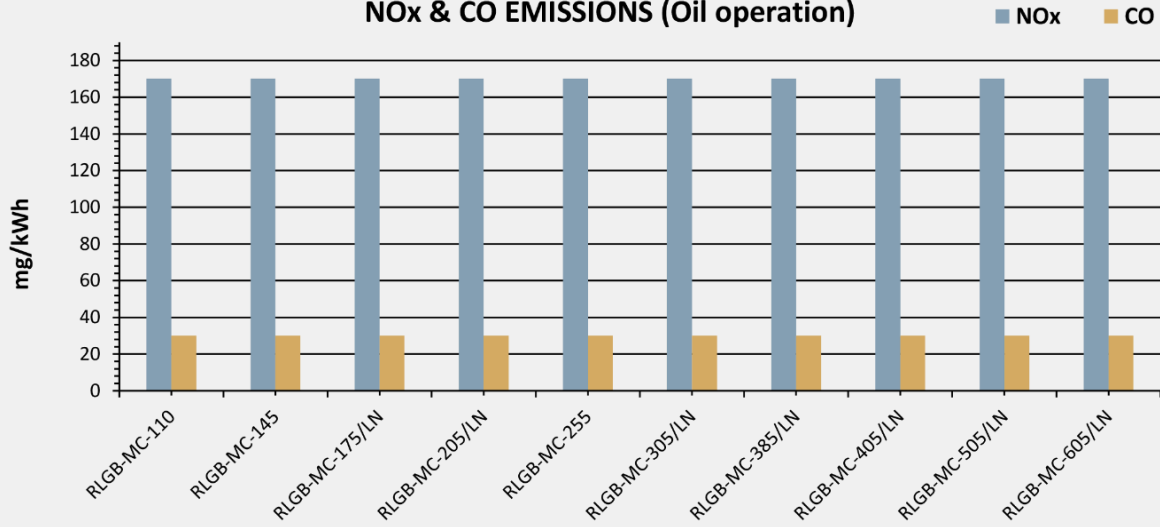

### Noise Level (RGB-MC Series)

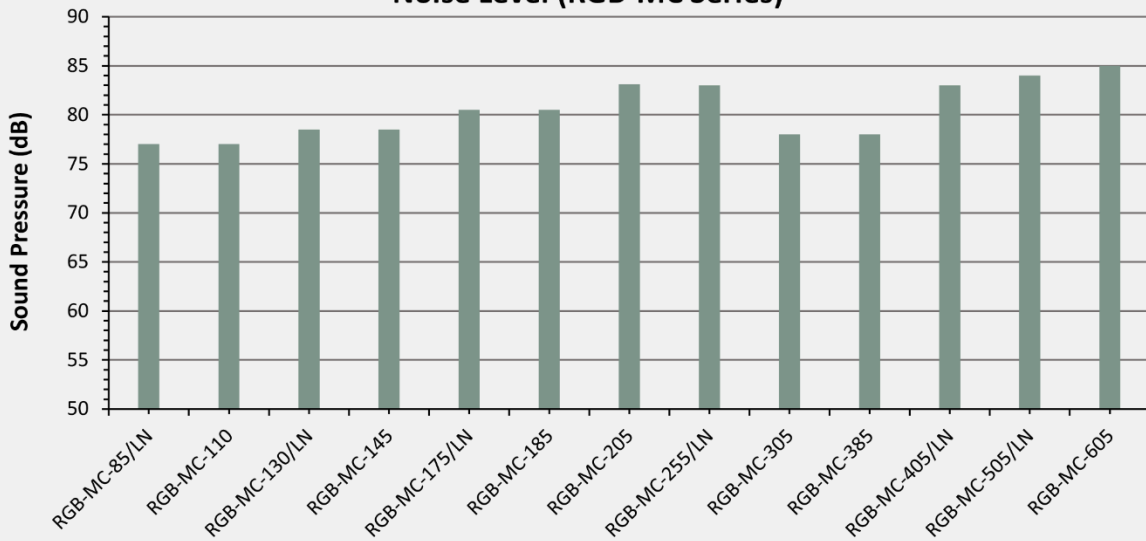

### Noise level (RLGB-MC Series)

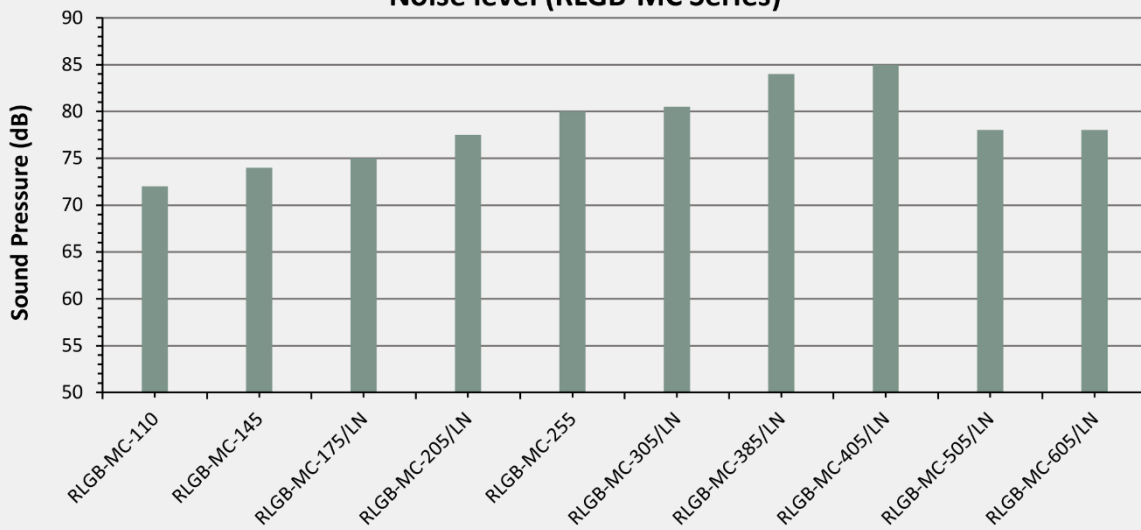

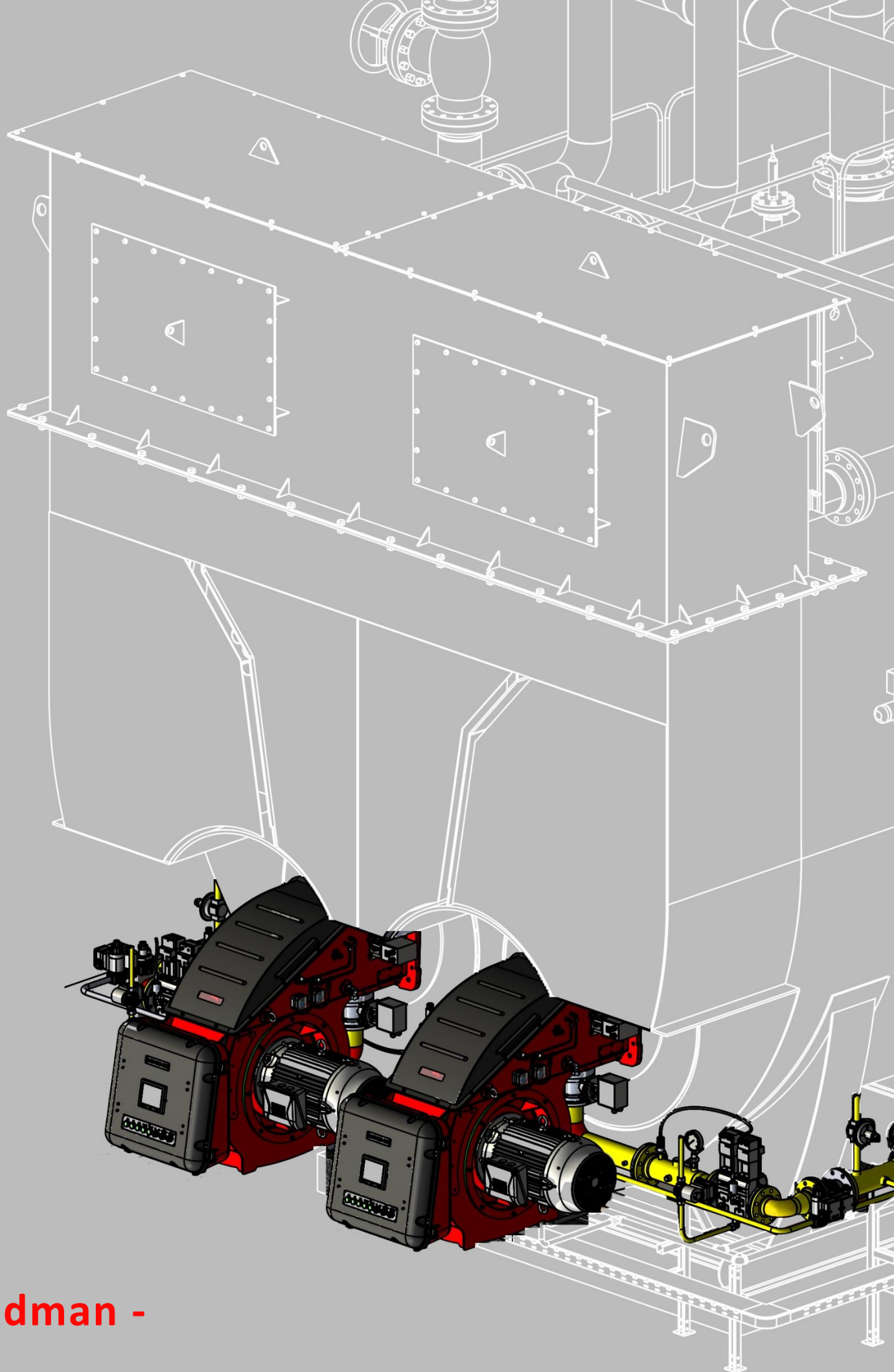

- raadman -



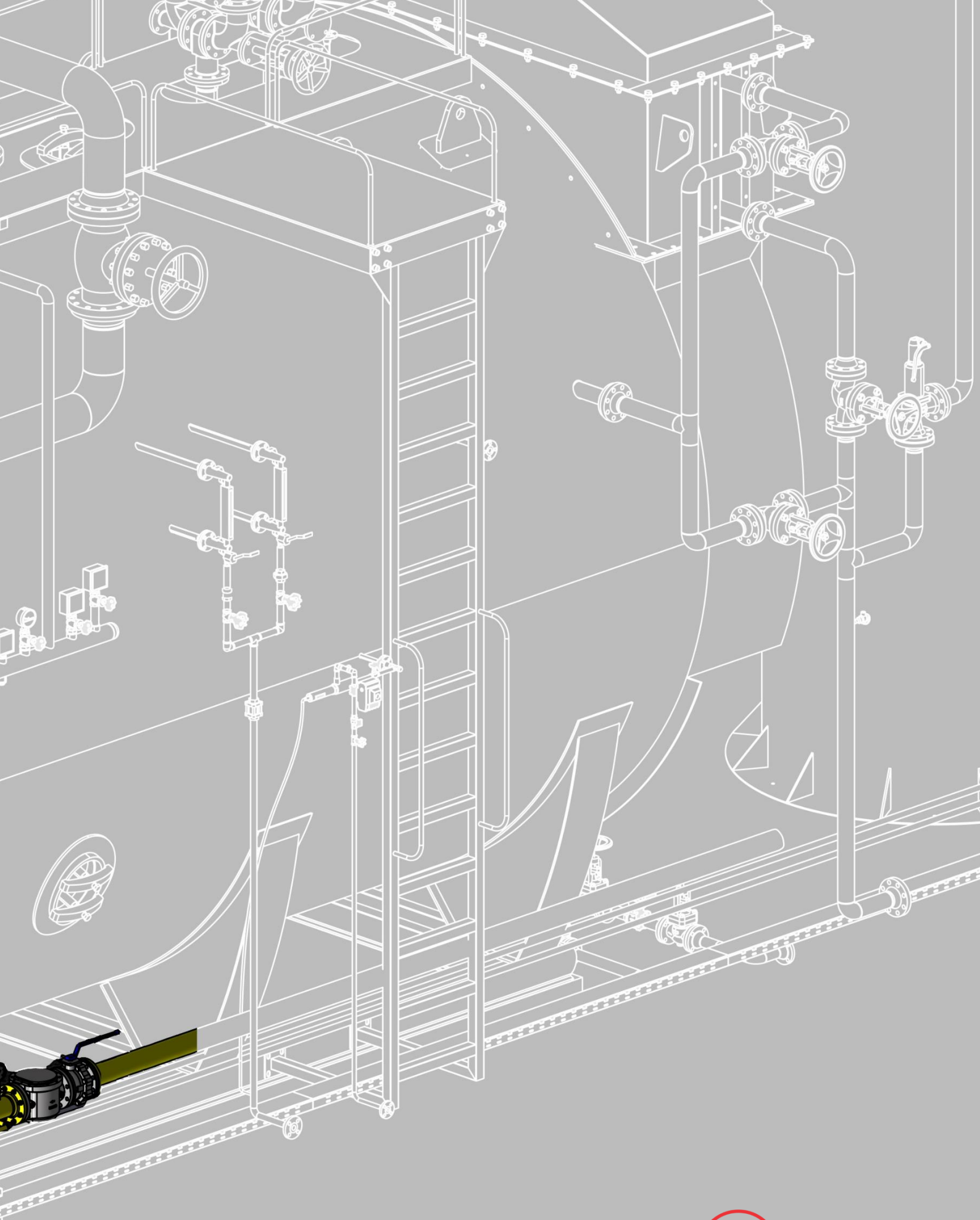



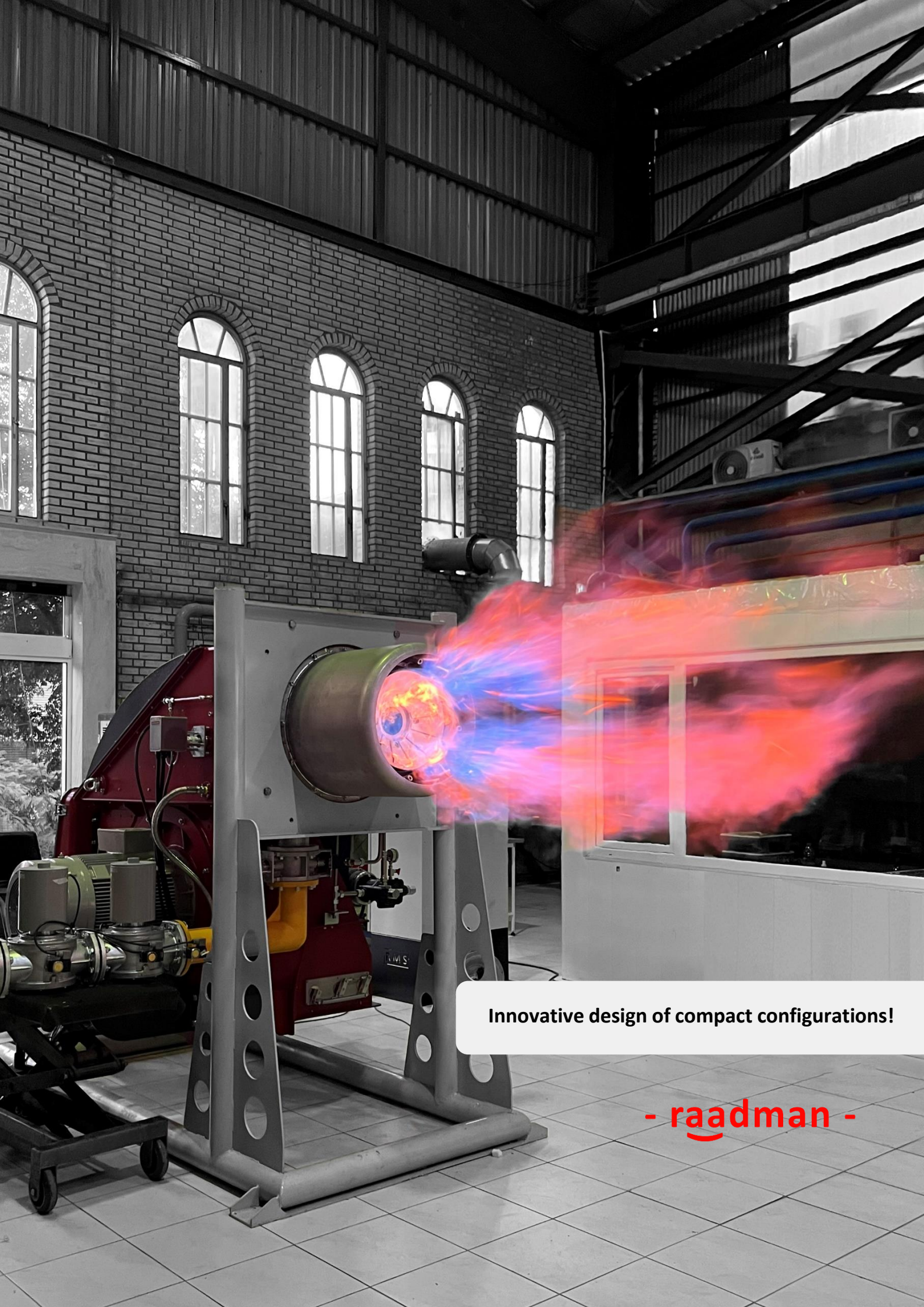

**Innovative design of compact configurations!**

**- raadman -**

# Electrical Modular Mono Block Burners

Heat Rated Output: 160-25000 kW



- SMILE INTO THE FUTURE -

[www.raadmanburner.com](http://www.raadmanburner.com)



## Electronic modular operation

Fossil fuel burners are often used as the principal means for delivering energy to industrial furnaces and boilers. Increasing emphasis on reducing energy costs has led manufacturers to concentrate on new burner design techniques. As a result, significant improvements in efficiency gains have been made over the years. The most effective strategies are burner management and control systems.

Fully modulating burners are designed to operate safely throughout its firing range from high fire to low fire. The most common turndown ratings in commercial boilers range from 1-3 up to 1-10. Turndown is how far the burner firing rate can be lowered and still effectively fire. High turndown is used to reduce the burner cycling and maintain a consistent temperature or pressure in the boiler. This is crucial if the boiler is used in an industrial process that requires a consistent temperature or pressure.

Each raadman burners with identification of –M- or –M/M- are equipped with an electronic microprocessor management panel which controls the air damper servomotor as well as the fuel servomotors. Using electronic modulation, hysteresis is prevented by the precise control of the separated and independent servomotors and the software linked by can-BUS.

The high precision regulation is due to the absence of mechanical clearance normally found in mechanical regulation cams on traditional modulating burners. The LAMTEC Burner Tronic BT300 or AUTOFLAME MINI MK8 or ETAMATIC OEM as well as Siemens LMV2/3, LM51/52 as the most popular brands, are frequently used in raadman Modular burners. The burner Control Systems combine the benefits of an electronic fuel/air ratio controller with an electronic burner control unit. Up to five motorized actuators can be assigned to modulate air and fuel drives with the option of an additional module to add variable speed drive control for the combustion air fan.

Additional modules are available for field bus interfacing, load control and dual fuel operation.

These modular systems include many standard burner functions as standard; these include: integrated valve proving, ambient temperature compensation, flame monitoring and operating hours and system start-up counters. Oxygen trim, CO control, load control and dual fuel functionality are all available options that are used to enhance system benefits, flexibility and efficiency. These controllers are particularly suited for using on mono-block burners.

The fuel/air ratio curves and operating parameters are set and adjusted using either UI300 HMI or AZL50 for LAMTEC and Siemens respectively or using their LSB Remote Software's. The fuel/air ratio can be optimized to compensate combustion variables by implementing oxygen trim or CO control to ensure that the burner operates to its maximum possible efficiency.

The burner and fuel/air ratio controller can be adjusted for a wide range of combustion tasks by setting parameters. In case of BT300, ETAMATIC OEM or LMV2/3/5, oil and gas can be set to start with and without a pilot burner. The integrated valve proving system can be run before ignition or after burner shutdown. In case of operation with gas, starting without pre-purge is possible in accordance with BS-EN676 and BS-EN 267.



**Key features and benefits include:**

- Integrated linkage-less control, burner flame safeguard and modulation PID control
- Single or dual fuel (or multi fuel) application
- Controls up to 5 independent actuators for optimal efficiency in low NOx burner application.
- Integrated PID temperature/ pressure controller with auto tune for extremely accurate process control
- Variable Speed Drive control with actual RPM speed sensor provides reliable, efficient and safe control of the combustion air blower
- Optional O<sub>2</sub>-CO trim
- Integrated gas valve proving system that checks for leak on every burner cycle for increasing safety.
- Up to 10 programmable points per fuel-air ratio curve for greater flexibility and tighter control
- 999 highly repeatable actuator position for precise control
- Digital positioning feedback from actuators ensure unmatched repeatability
- Independent ignition position
- Ability of being connected to building management system using different type of protocols
- World-wide approvals and technical supports

# raadman electronic modular burners

raadman electronic modular gas burners, covering a firing range from 160 to 25000 kW, are designed for a wide range of domestic and industrial applications. All raadman electronic modular burners are equipped with LAMTEC or SIEMENS electronic control system with capability of full air/gas ratio control throughout entire burner operating range. These burners have been tested and evaluated based on Iran national standard ISIRI-7595 (BS-EN 676). According to the conducted

experiments, the value of CO even in low excess air operation is lower than 30 mg/kWh (In some cases, values close to zero have also been reported). The precise design of combustion head results in a full gas-air mixture that guarantees high efficiency levels in all various applications. Burner superior design accompanied by high quality electronic devices have also resulted in a further improvement in boiler's performance in order to decrease the fuel cost and emissions.

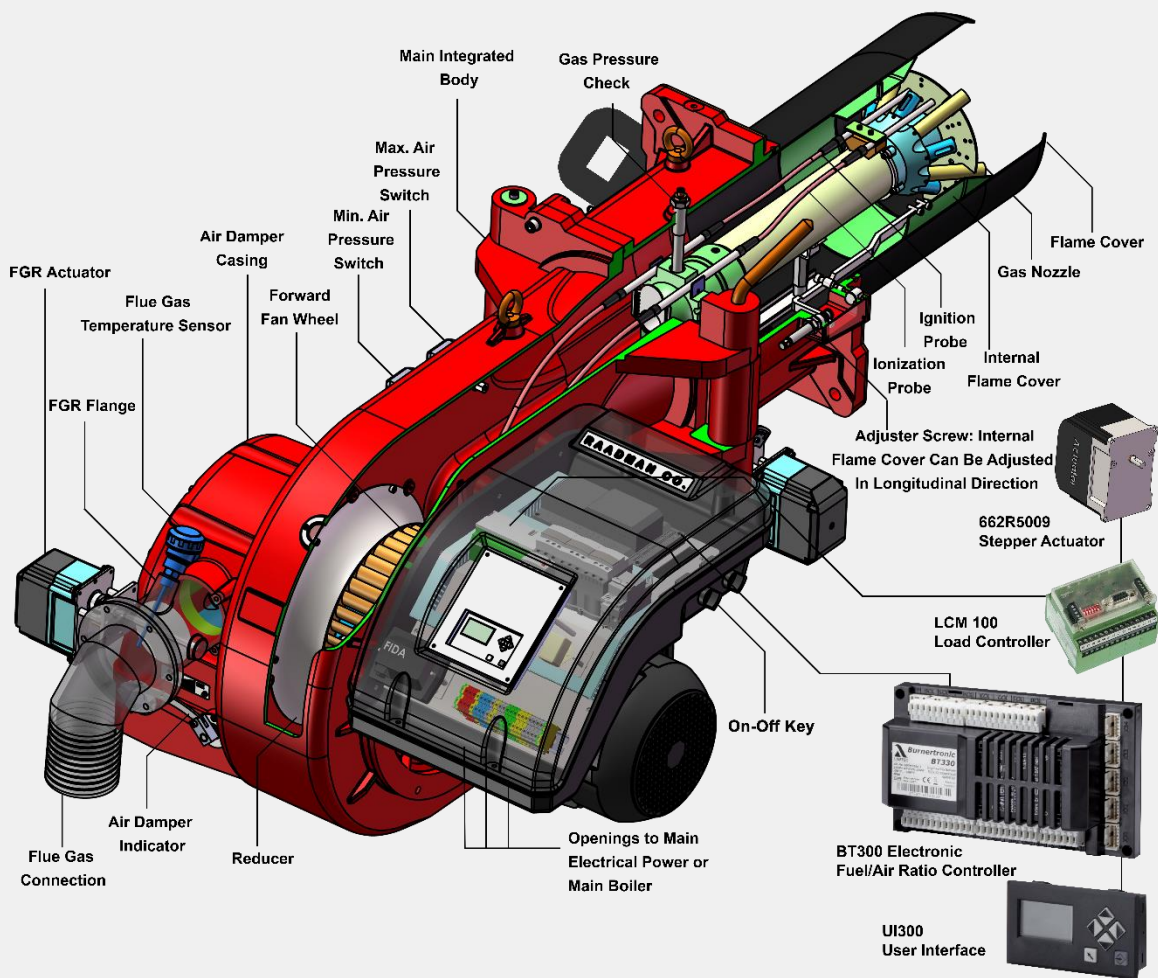





# Burner management system overview

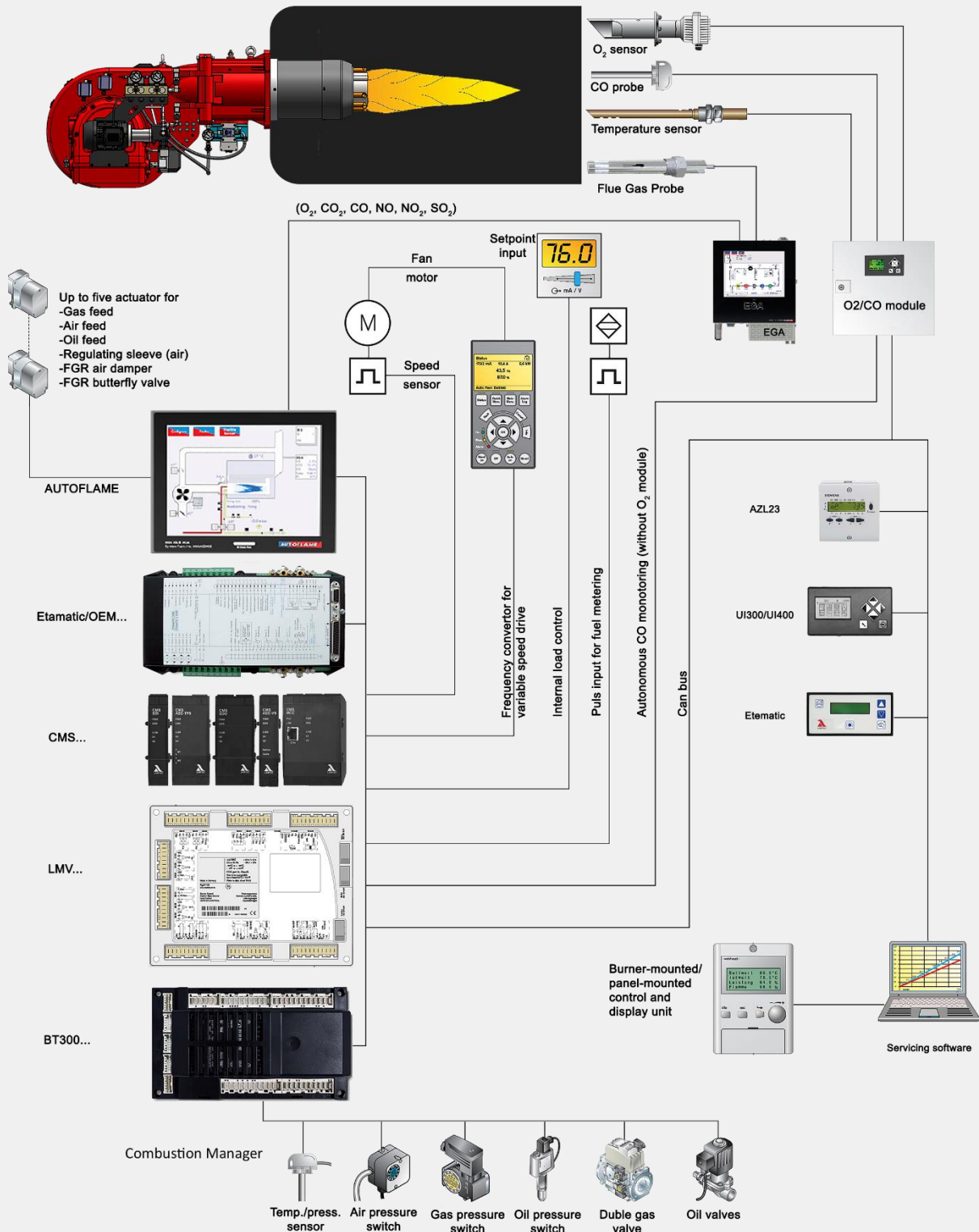

## raadman RGB-M series burner

RGB-M Series or raadman Modular gas burners, covering a firing range from 160 to 25000 kW, are designed for a wide range of domestic and industrial applications. All raadman modular burners are equipped with LAMTEC or SIEMENS or AUTOFLAME electronic control system with capability of full air/gas ratio control throughout entire burner operating range. These burners have been tested and evaluated based on Iran national standard ISIRI-7595 (BS-EN 676). According to performed experiments, the values of CO even in low excess air operation is lower than 30 mg/kWh (In some cases, values close to zero have also been reported). The precise design of combustion head results a full gas-air mixture that guarantees high efficiency levels in all various applications. Burner superior design accompanied by high quality electronic devices have also resulted a further improvement in boiler's performance in order to decrease the fuel cost and emissions.

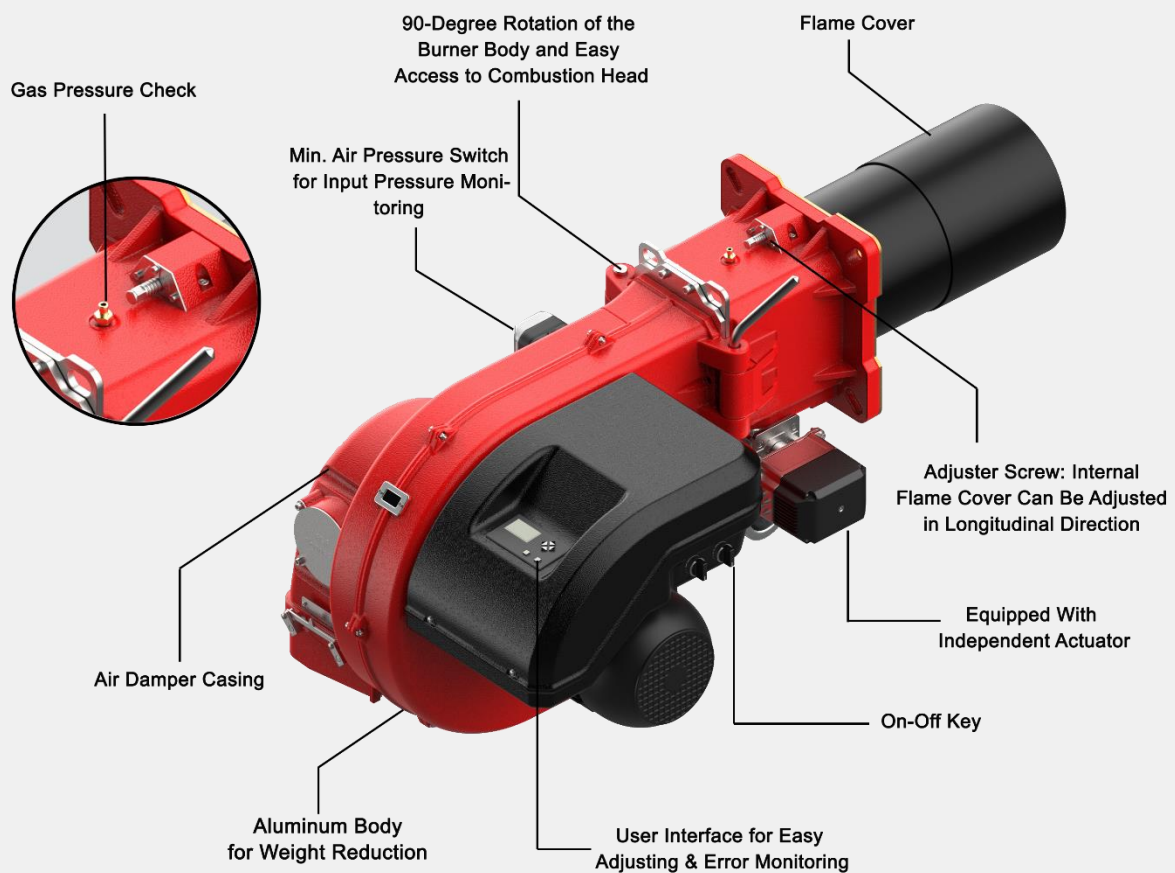



## Burner selection: capacity and working diagram

### Modulating Gas Burner

Burner	Capacity (kW)	Turn down	Burner	Capacity (kW)	Turn down
RGB-M-55	NG: 160-580	1:3	RGB-M-80	NG: 297-810	1:3

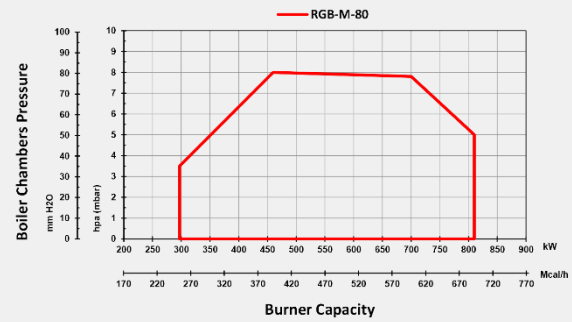
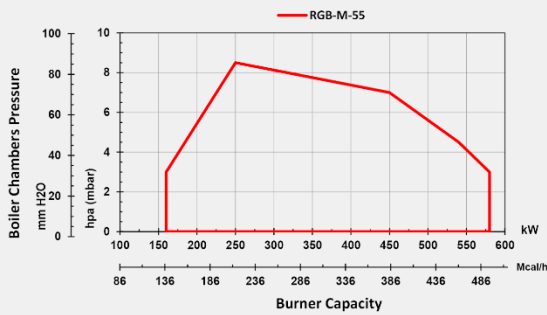

Burner	Capacity (kW)	Turn down
RGB-M-85/LN	NG: 250-900	1:3
RGB-M-130/LN	NG: 350-1280	1:3

Burner	Capacity (kW)	Turn down
RGB-M-110	NG: 350-1150	1:3
RGB-M-145	NG: 400-1480	1:4

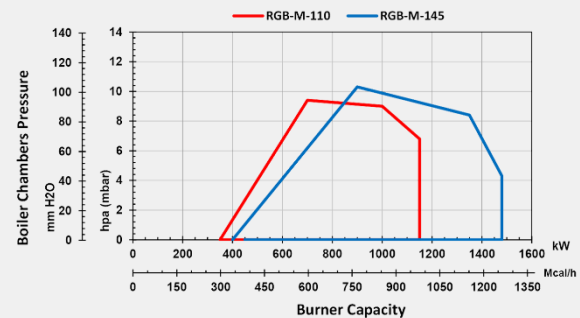
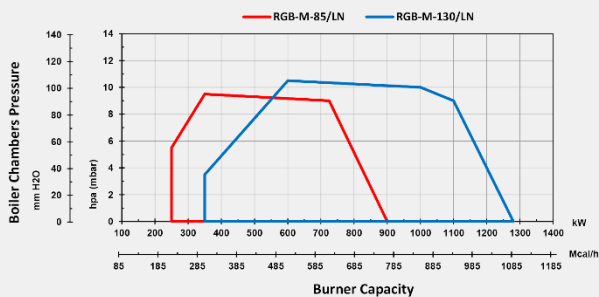



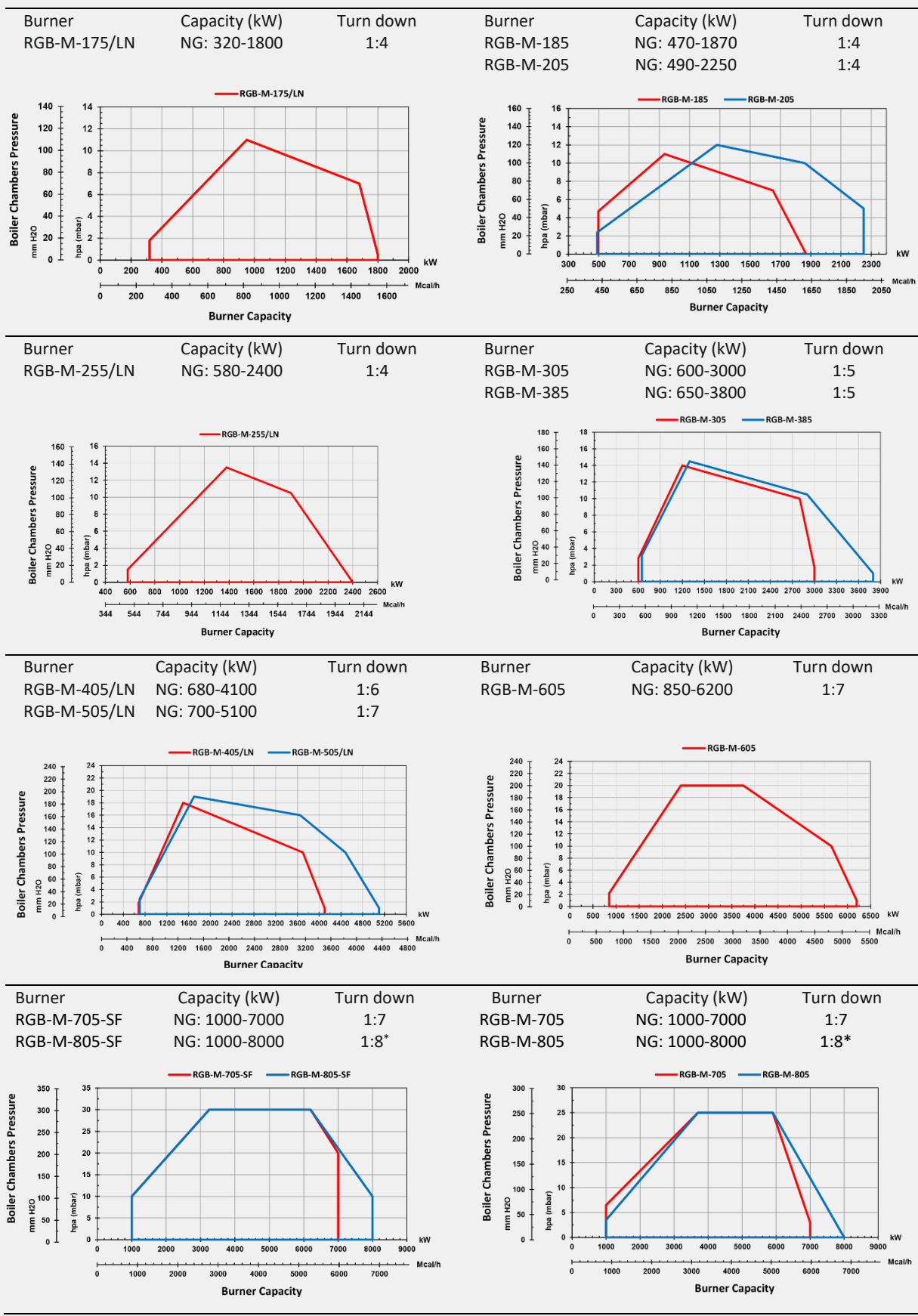



Burner	Capacity (kW)	Turn down
RGB-M-950	NG: 1000-9000	1:9*
RGB-M-1050	NG: 1000-10500	1:10*
RGB-M-1250	NG: 1200-12000	1:10*

Burner	Capacity (kW)	Turn down
RGB-M-1350	NG: 1350-13500	1:10*

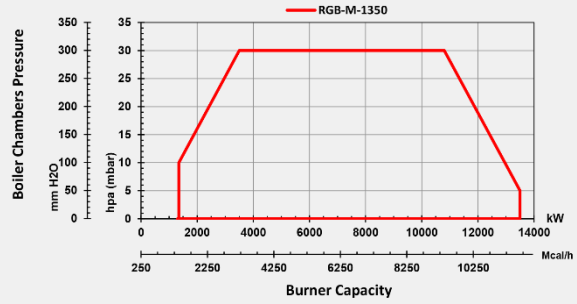
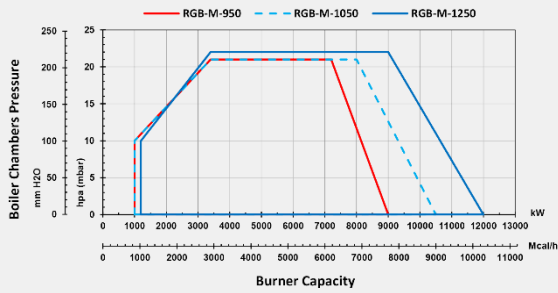

Burner	Capacity (kW)	Turn down
RGB-M-1550	NG:1900-15000	1:8*

Burner	Capacity (kW)	Turn down
RGB-M-1750	NG: 2200-17000	1:8*

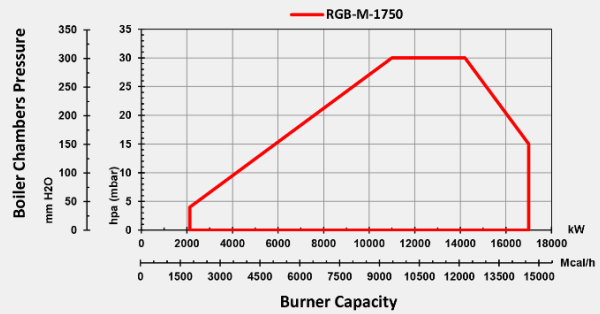
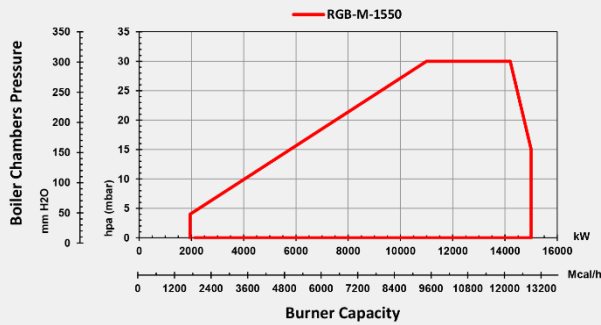

Burner	Capacity (kW)	Turn down
RGB-M-2250	NG:2750-22000	1:8*

Burner	Capacity (kW)	Turn down
RGB-M-2550	NG: 3150-25000	1:8*

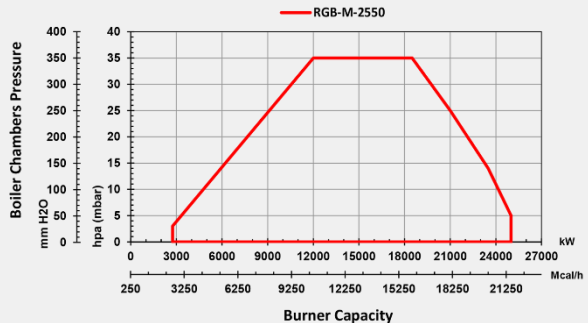
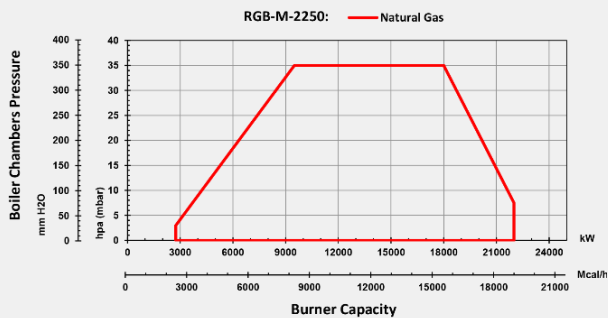

About the working diagram: Working diagrams for gaseous fuel burners are certified in accordance with BS-EN 676. The firing rate diagram has been obtained considering the ambient temperature of 20°C and atmospheric pressure of 1013 mbar (Sea level condition).

\* Special note: Turn-down ratio higher than (1:8, 1:9, 1:10, etc.) are accessible for the burner with the head actuator. Otherwise, without a head actuator, the max. turn-down ratio is 1:6.



- raadman -

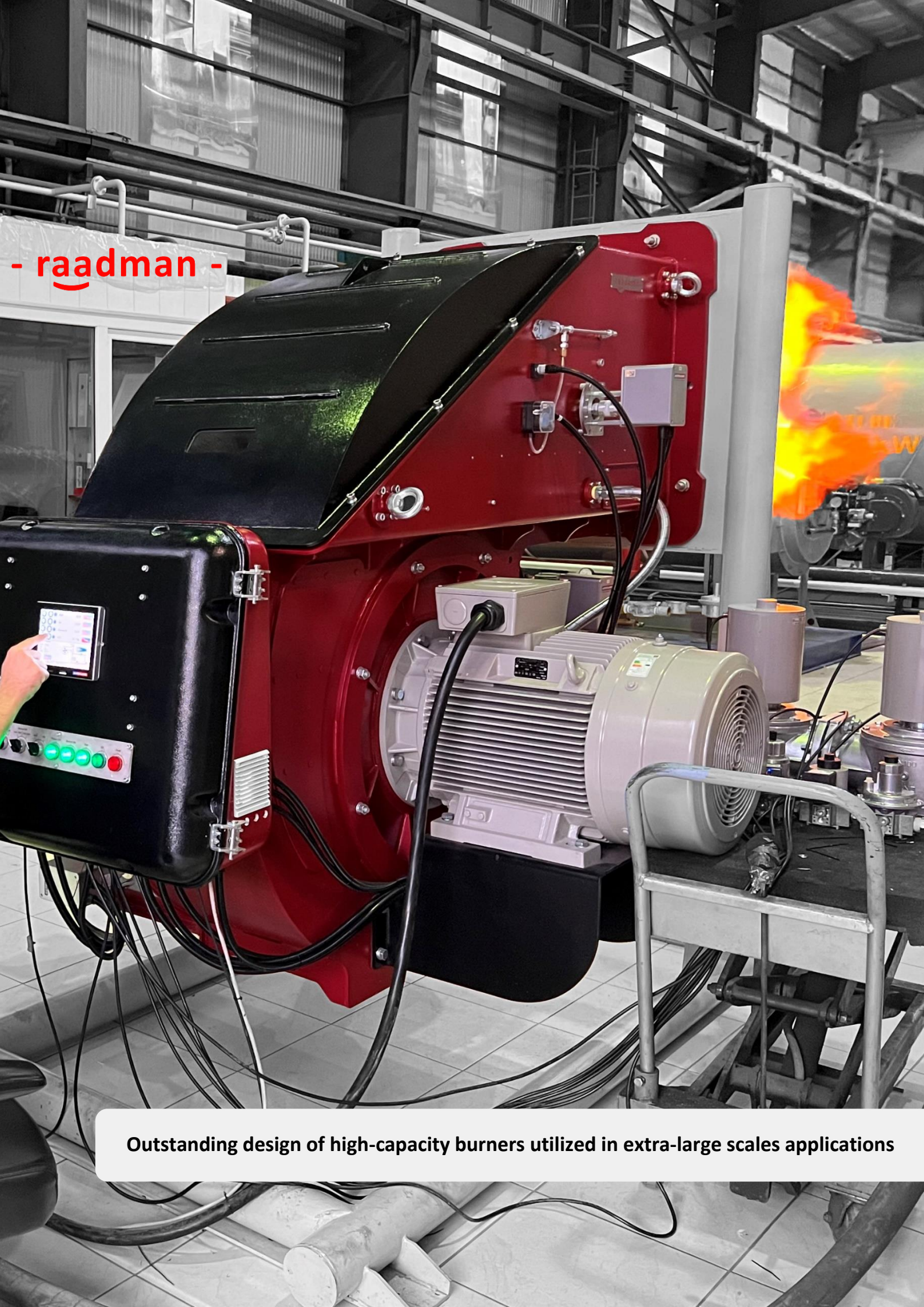

Outstanding design of high-capacity burners utilized in extra-large scales applications



# General dimension: RGB-M series

## RGB-M-55

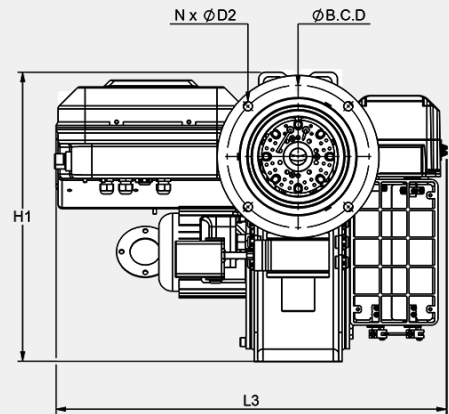
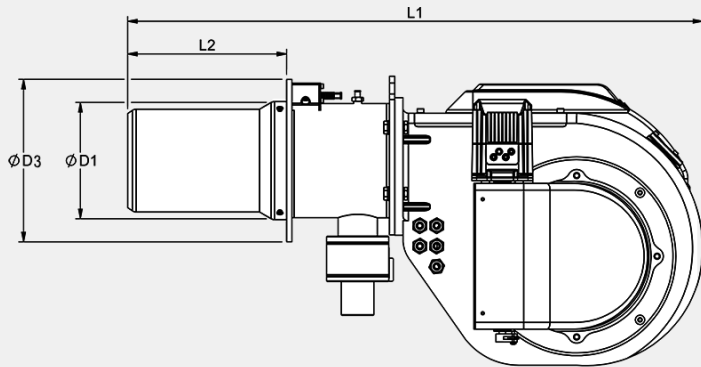

With AL-Casing

Burner Type	L <sub>1</sub>	L <sub>2</sub>	L <sub>3</sub>	H	D <sub>1</sub>	D <sub>2</sub>	D <sub>3</sub>	N	B.C. D
RGB-M-55	850	235	576	427	179	13.5	240	4	210

## RGB-M-80

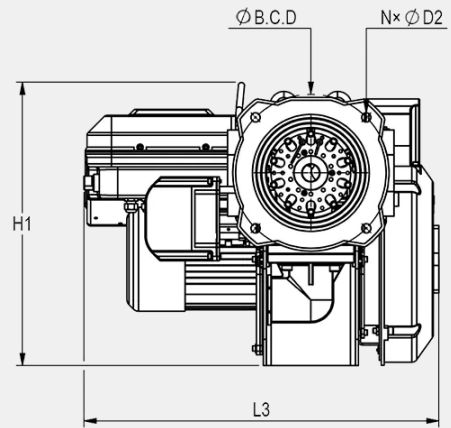
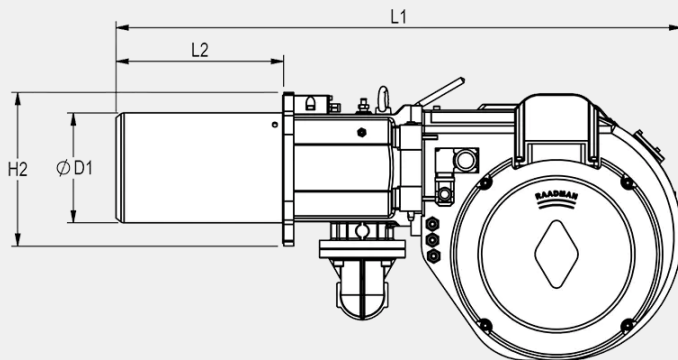

With AL-Casing

Burner Type	L <sub>1</sub>	L <sub>2</sub>	L <sub>3</sub>	H <sub>1</sub>	H <sub>2</sub>	D <sub>1</sub>	D <sub>2</sub>	N	B.C. D
RGB-M-80	921	273	578	461	254	183	15	4	255

### RGB-M-85/LN, RGB-M-130/LN

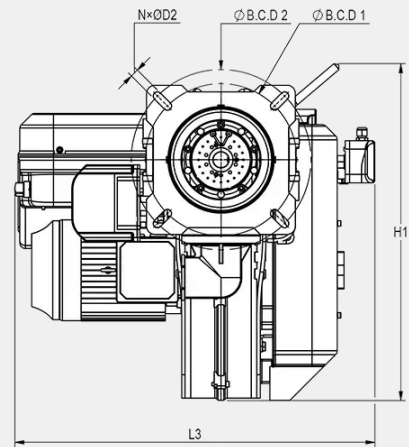
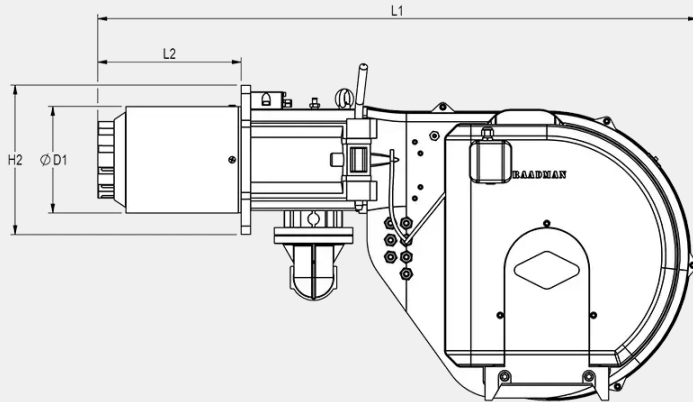

With AL-Casing

Burner Type	L <sub>1</sub>	L <sub>2</sub>	L <sub>3</sub>	H <sub>1</sub>	H <sub>2</sub>	D <sub>1</sub>	D <sub>2</sub>	N	B.C.D.1	B.C.D.2
RGB-M-85/LN	1068	255	641	598	265	194	15	4	270	320
RGB-M-130/LN	1072	260	641	598	265	194	15	4	270	320

### RGB-M-110, RGB-M-145

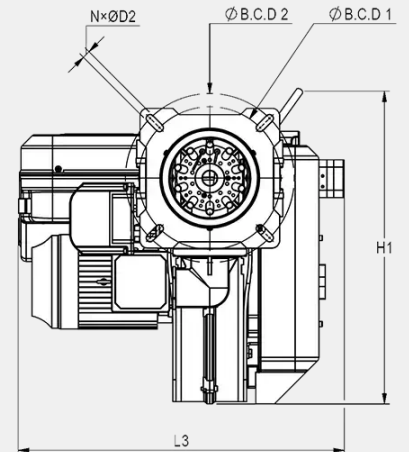
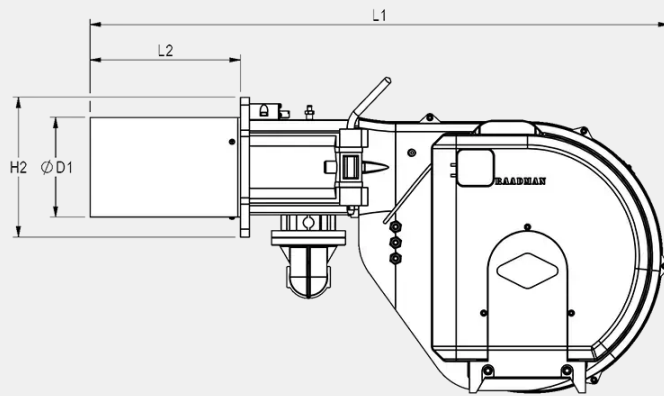

With AL-Casing

Burner Type	L <sub>1</sub>	L <sub>2</sub>	L <sub>3</sub>	H <sub>1</sub>	H <sub>2</sub>	D <sub>1</sub>	D <sub>2</sub>	N	B.C.D.1	B.C.D.2
RGB-M-110	1066	254	638	598	265	184	15	4	270	320
RGB-M-145	1097	285	638	598	265	194	15	4	270	320

### RGB-M-175/LN

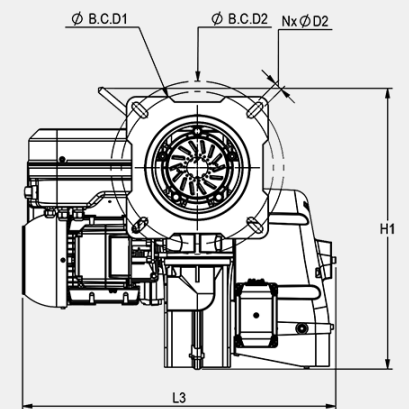
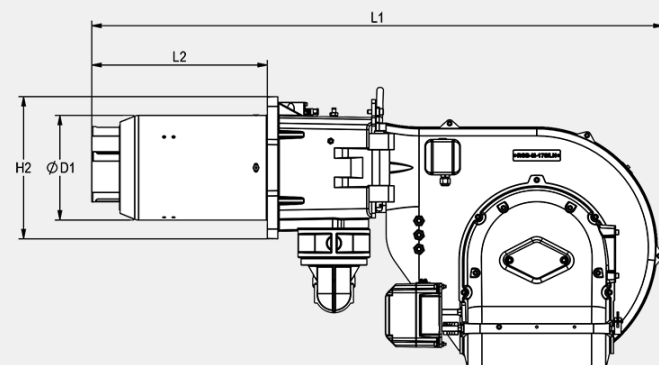

With AL-Casing

Burner Type	L <sub>1</sub>	L <sub>2</sub>	L <sub>3</sub>	H <sub>1</sub>	H <sub>2</sub>	D <sub>1</sub>	D <sub>2</sub>	N	B.C.D.1	B.C.D.2
RGB-M-175/LN	1213	373	665	598	302	226	18	4	323	367

### RGB-M-185, RGB-M-205

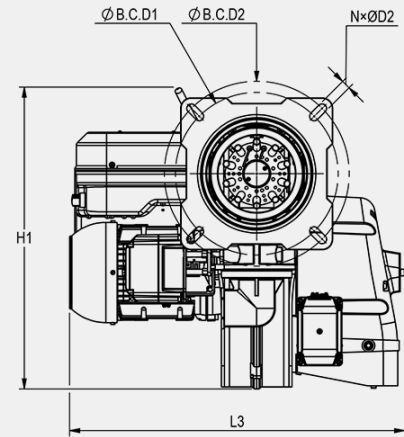
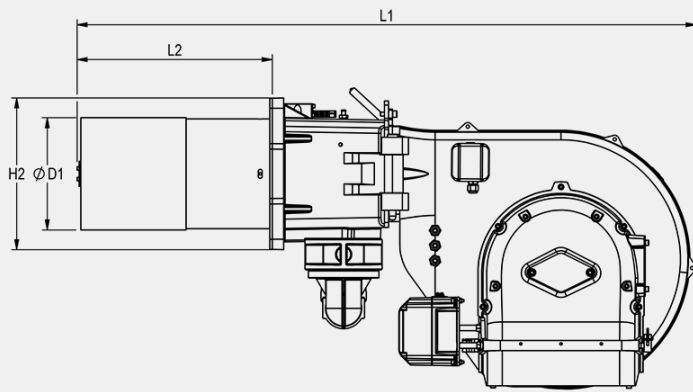

With AL-Casing

Burner Type	L <sub>1</sub>	L <sub>2</sub>	L <sub>3</sub>	H <sub>1</sub>	H <sub>2</sub>	D <sub>1</sub>	D <sub>2</sub>	N	B.C.D.1	B.C.D.2
RGB-M-185	1229	387.5	665	598	301	223	18	4	323	367
RGB-M-205	1229	387.5	665	598	301	223	18	4	323	367

### RGB-M-255/LN

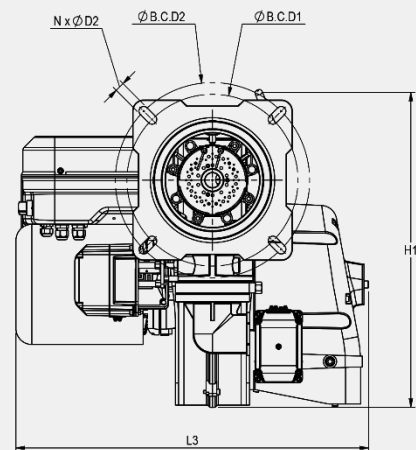
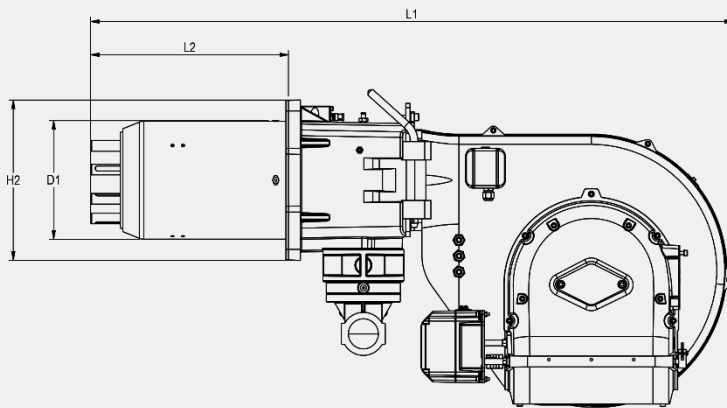

With AL-Casing

Burner Type	L <sub>1</sub>	L <sub>2</sub>	L <sub>3</sub>	H <sub>1</sub>	H <sub>2</sub>	D <sub>1</sub>	D <sub>2</sub>	N	B.C.D.1	B.C.D.2
RGB-M-255/LN	1214	374	762	598	300	226	18	4	323	368



### RGB-M-305, RGB-M-385

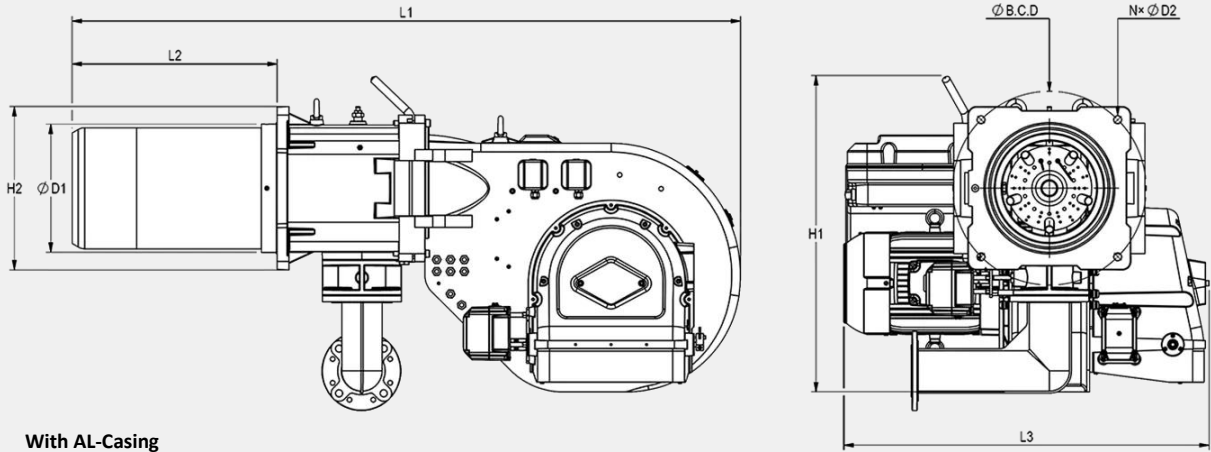

With AL-Casing

Burner Type	L <sub>1</sub>	L <sub>2</sub>	L <sub>3</sub>	H <sub>1</sub>	H <sub>2</sub>	D <sub>1</sub>	D <sub>2</sub>	N	B.C. D
RGB-M-305	1689	520	927	741	413	328	20	4	490
RGB-M-385	1689	520	927	741	413	328	20	4	490

### RGB-M-405/LN, RGB-M-505/LN

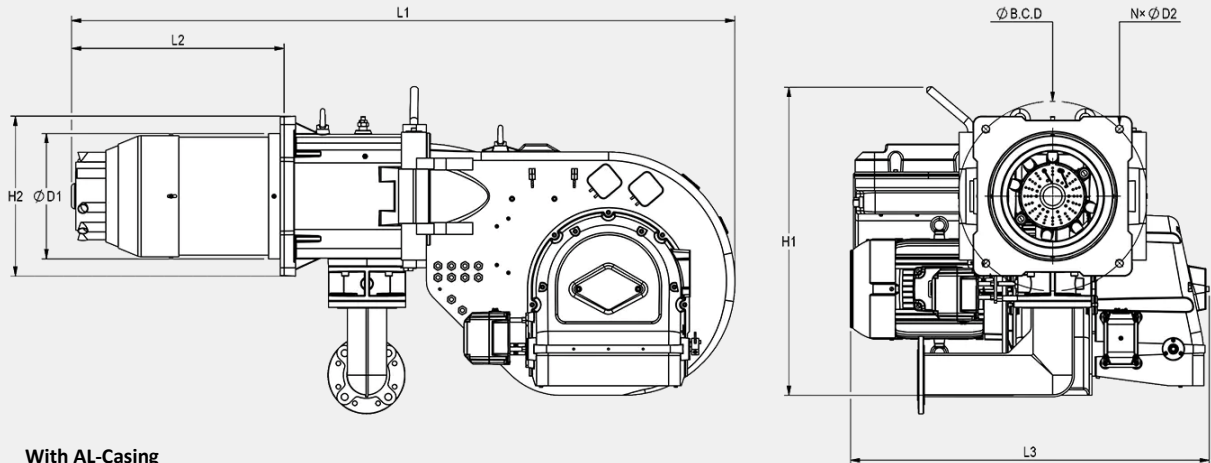

With AL-Casing

Burner Type	L <sub>1</sub>	L <sub>2</sub>	L <sub>3</sub>	H <sub>1</sub>	H <sub>2</sub>	D <sub>1</sub>	D <sub>2</sub>	N	B.C. D
RGB-M-405/LN	1721	552	930	798	413	328	20	4	490
RGB-M-505/LN	1721	552	1026	798	413	328	20	4	490

### RGB-M-605

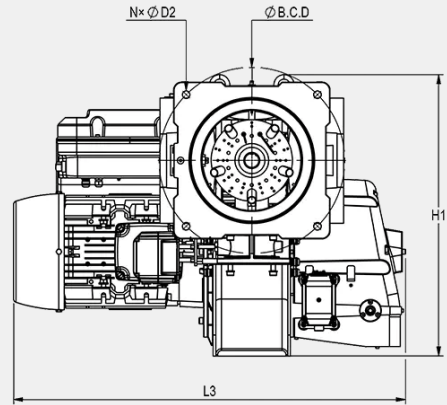
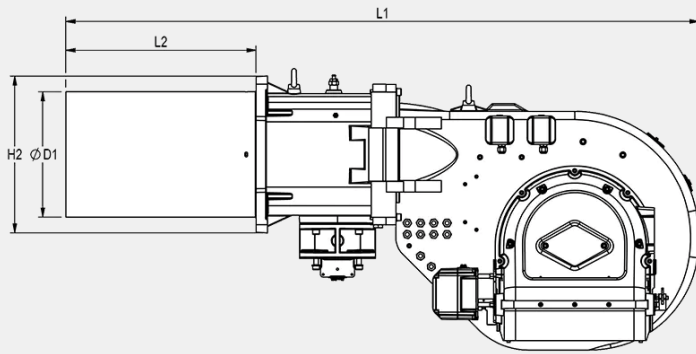

With AL-Casing

Burner Type	L <sub>1</sub>	L <sub>2</sub>	L <sub>3</sub>	H <sub>1</sub>	H <sub>2</sub>	D <sub>1</sub>	D <sub>2</sub>	N	B.C. D
RGB-M-605	1671	502	1035	741	413	334	20	4	490

### RGB-M-705-SF, RGB-M-705, RGB-M-950, RGB-M-1050

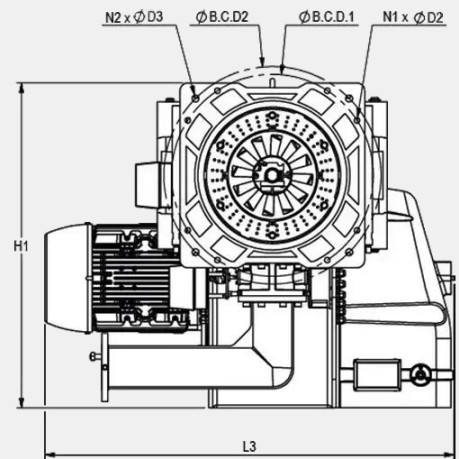
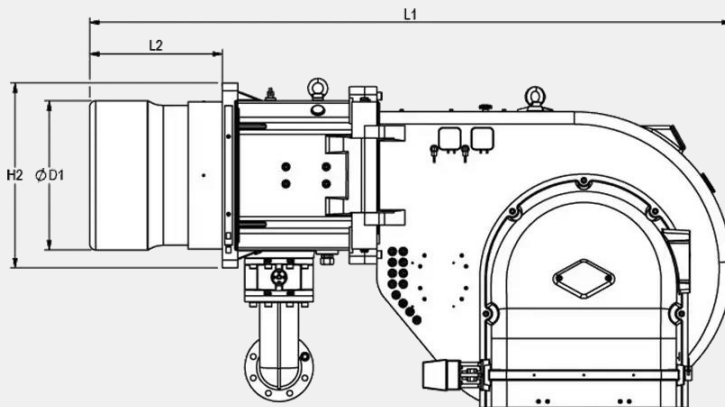

With AL-Casing

Burner Type	L <sub>1</sub>	L <sub>2</sub>	L <sub>3</sub>	H <sub>1</sub>	H <sub>2</sub>	D <sub>1</sub>	D <sub>2</sub>	D <sub>3</sub>	N <sub>1</sub>	N <sub>2</sub>	B.C.D1*	B.C.D2*
RGB-M-705-SF	1816	350	1168	950	501	405	----	22	-	4	----	590
RGB-M-705	1886	420	1168	950	501	405	----	22	-	4	----	590
RGB-M-950	2069	428	1328	1046	595	480	17.5	22	8	4	650	700
RGB-M-1050	2069	428	1328	1046	595	480	17.5	22	8	4	650	700

**RGB-M-705-SF, RGB-M-705, RGB-M-805-SF, RGB-M-805, RGB-M-950, RGB-M-1050**

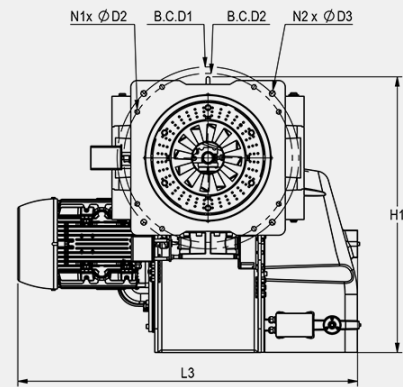
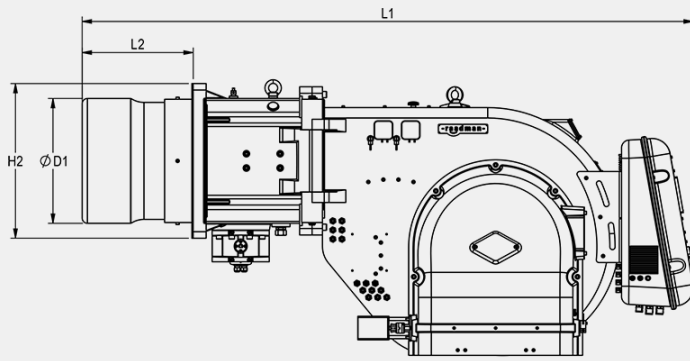

With AL-Casing

Burner Type	L <sub>1</sub>	L <sub>2</sub>	L <sub>3</sub>	H <sub>1</sub>	H <sub>2</sub>	D <sub>1</sub>	D <sub>2</sub>	D <sub>3</sub>	N <sub>1</sub>	N <sub>2</sub>	B.C.D1*	B.C.D2*
RGB-M-705-SF	2111	350	1168	950	501	400	----	22	4	-	590	
RGB-M-705	2161	420	1212	950	501	400	----	22	4	-	590	
RGB-M-805-SF	2111	350	1168	950	501	400	----	22	4	-	590	
RGB-M-805	2161	420	1212	950	501	400	----	22	4	-	590	
RGB-M-950	2375	428	1328	1046	595	480	17.5	22	8	4	650	700
RGB-M-1050	2375	428	1328	1046	595	480	17.5	22	8	4	650	700

**RGB-M-950, RGB-M-1050, RGB-M-1250, RGB-M-1350, RGB-M-1550, RGB-M-1750, RGB-M-2250, RGB-M-2550**

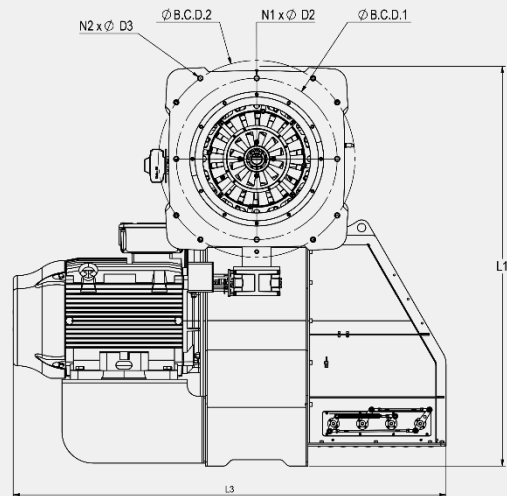
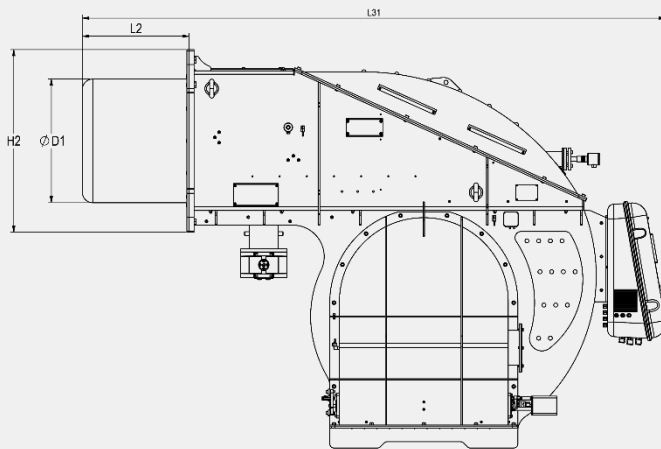

With Carbon-steel Casing

Burner Type	L <sub>1</sub>	L <sub>2</sub>	L <sub>3</sub>	H <sub>1</sub>	H <sub>2</sub>	D <sub>1</sub>	D <sub>2</sub>	D <sub>3</sub>	N <sub>1</sub>	N <sub>2</sub>	B.C.D1*	B.C.D2*
RGB-M-950	2060	428	1300	1046	613	480	17.5	22	8	4	650	700
RGB-M-1050	2060	428	1300	1046	613	480	17.5	22	8	4	650	700
RGB-M-1250	2008	367	1313	1320	613	480	17.5	22	8	4	650	700
RGB-M-1350	2258	367	1550	1546	660	480	20	20	4	4	590	790
RGB-M-1550	2585	510	1762	1822	872	590	20	20	4	8	770	940
RGB-M-1750	2585	510	1762	1822	872	590	20	20	4	8	770	940
RGB-M-2250	2790	508	2072	1906	872	590	20	20	4	8	770	940
RGB-M-2550	2790	508	2072	1906	872	590	20	20	4	8	770	940

\* **Note:** For the hole patterns of the burner flange, kindly refer to the burner technical proposals while placing an order.





#A\_LOOK\_TO\_THE\_FUTURE

RCB-M-385

PACKMAN

## Technical data: RGB-M series

- N.G operation: Electronic Modular

Power system		Power management system				
Burner	Motor(kW/PH/V/HZ/rpm)	Controller		Actuator (N.M)		
		Brand	Model	Air	Fuel	Head
RGB-M-55	0.75/3/380-400/50/2840	LAMTEC	BT320	1.2	0.8	--
RGB-M-80	1.1/3/380-400/50/2840	LAMTEC	BT320	1.2	1.2	--
RGB-M-85/LN	1.5 /3/380-400/50/2840	LAMTEC	BT320	1.2	1.2	--
		SIEMENS	LMV27/37			
RGB-M-110	1.5 /3/380-400/50/2840	LAMTEC	BT320	3	1.2	--
		SIEMENS	LMV27/37			
RGB-M-130/LN	2.2 /3/380-400/50/2840	LAMTEC	BT320	3	1.2	--
		SIEMENS	LMV3...			
RGB-M-145	2.2 /3/380-400/50/2840	LAMTEC	BT320	3	1.2	--
		SIEMENS	LMV27/37			
RGB-M-175/LN	4 /3/380-400/50/2840	LAMTEC	BT320	3	1.2	--
		SIEMENS	LMV3...			
RGB-M-185	5.5 /3/380-400/50/2840	LAMTEC	BT320	3	1.2	--
		SIEMENS	LMV27/37			
RGB-M-205	5.5 /3/380-400/50/2840	LAMTEC	BT320	3	1.2	--
		SIEMENS	LMV27/37			
RGB-M-255/LN	5.5 /3/380-400/50/2840	LAMTEC	BT320	3	1.2	--
		SIEMENS	LMV27/37			
RGB-M-305	7.5 /3/380-400/50/2900	LAMTEC	BT320	3	1.2	--
		SIEMENS	LMV27/37			
RGB-M-385	7.5 /3/380-400/50/2900	LAMTEC	BT320	3	1.2	--
		SIEMENS	LMV27/37			
RGB-M-405/LN	11 /3/380-400/50/2900	LAMTEC	BT320	9	1.2	--
		SIEMENS	LMV27/37	10	1.2	
RGB-M-505/LN	11 /3/380-400/50/2900	LAMTEC	BT320	9	1.2	--
		SIEMENS	LMV27/37	10	1.2	
RGB-M-605/LN	15 /3/380-400/50/2900	LAMTEC	BT320	9	1.2	--
		SIEMENS	LMV27/37	10	1.2	
RGB-M-705-SF RGB-M-705	18.5 /3/380-400/50/2840	LAMTEC	BT320	9	1.2	--
		AUTOFLAME	MINI MK8	25	4	
RGB-M-805-SF	18.5 /3/380-400/50/2840	AUTOFLAME	MINI MK8	25	4	--
RGB-M-805	22 /3/380-400/50/2840	AUTOFLAME	MINI MK8	25	4	--





Power syste		Power management system				
Burner	Motor(kW/PH/V/HZ/rpm)	Controller		Actuator (N.M)		
		Brand	Model	Air	Fuel	Head*
RGB-M-950	22/3/380-400/50/2840	LAMTEC	ETAMATIC-OEM	20	6	20
		SIEMENS	LMV 5...	20	3	20
		AUTOFLAME	MINI MK8	25	4	25
RGB-M-1050	22/3/380-400/50/2840	LAMTEC	ETAMATIC-OEM	20	6	20
		SIEMENS	LMV 5...	20	3	20
		AUTOFLAME	MINI MK8	25	4	25
RGB-M-1250	30/3/380-400/50/2840	LAMTEC	ETAMATIC-OEM	20	6	20
		SIEMENS	LMV 5...	20	3	20
		AUTOFLAME	MINI MK8	25	4	25
RGB-M-1350	37/3/380-400/50/2840	LAMTEC	ETAMATIC-OEM	20	6	20
		SIEMENS	LMV 5...	20	3	20
		AUTOFLAME	MINI MK8	25	4	25
RGB-M-1550	45/3/380-400/50/2900	LAMTEC	ETAMATIC-OEM	20	6	20
		SIEMENS	LMV 5...	20	3	20
		AUTOFLAME	MINI MK8	25	4	25
RGB-M-1750	45/3/380-400/50/2900	LAMTEC	ETAMATIC-OEM	20	6	20
		SIEMENS	LMV 5...	20	3	20
		AUTOFLAME	MINI MK8	25	4	25
RGB-M-2250	75/3/380-400/50/2900	LAMTEC	ETAMATIC-OEM	40	6	40
		SIEMENS	LMV 5...	35	3	35
		AUTOFLAME	MINI MK8	25	4	40
RGB-M-2550	75/3/380-400/50/2900	LAMTEC	ETAMATIC-OEM	40	6	40
		SIEMENS	LMV 5...	35	3	35
		AUTOFLAME	MINI MK8	25	4	40

Note:Using combustion head actuator is necessary in burners with capacity of 15 mW and higher.



## raadman RLGB-M series burner

RLGB-M series or raadman electronic modular dual fuel burners, covering a firing range from 160 to 25000 kW, are designed for a wide range of domestic and industrial applications. These burners have been tested and evaluated based on Iran national standards ISIRI-7595 (BS-EN 676) and ISIRI-7594 (BS-EN 267) for gas and oil operation, respectively. According to the performed experiments, the values of CO during low excess air operation is lower than 30 mg/kWh (in some cases very close to Zero). The precise design of their combustion head results in a full gas-air mixture that guarantees high efficiency levels in all various applications. These burners are equipped with LAMTEC and SIEMENS control systems with capability of full air/gas ratio control throughout entire burner operating range as well as devices of well-known European companies such as Dungs, Kromschroeder and Suntec. Burner superior design accompanied by high quality electronic devices have also resulted in a further improvement in boiler performance in order to decrease fuel cost and emissions.

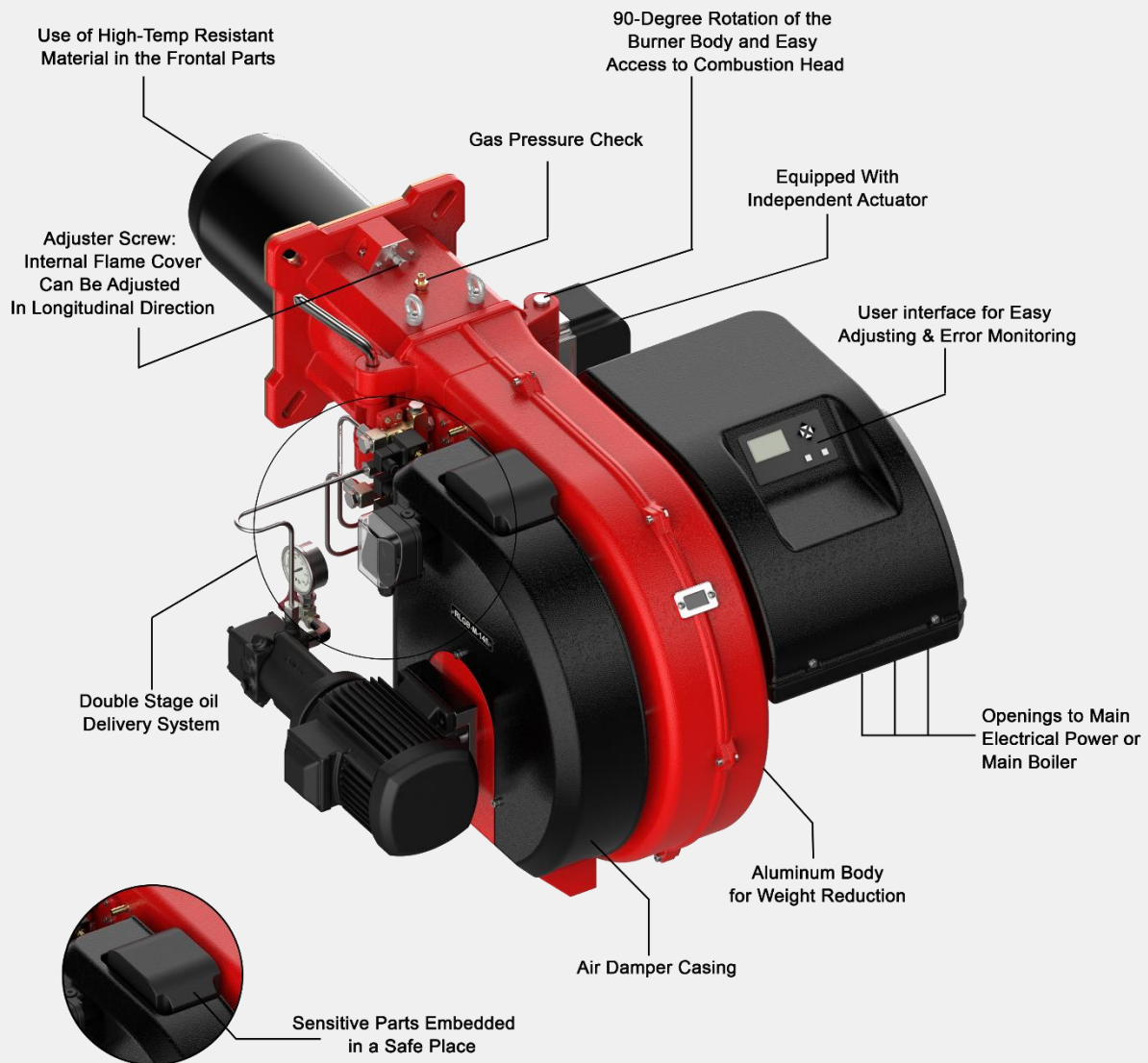



# Burner selection: capacity and working diagram

## Modulating Dual-fuel Burner

Burner	Capacity (kW)	Turn down	Burner	Capacity (kW)	Turn down
RLGB-M-55	NG: 160-580	1:3	RLGB-M-85	NG: 297-810	1:3
	LFO: 160-580	1:3		LFO: 297-810	1:3

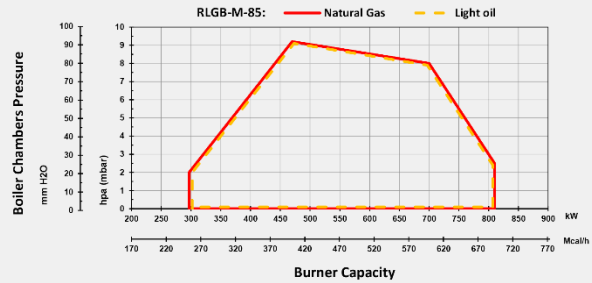
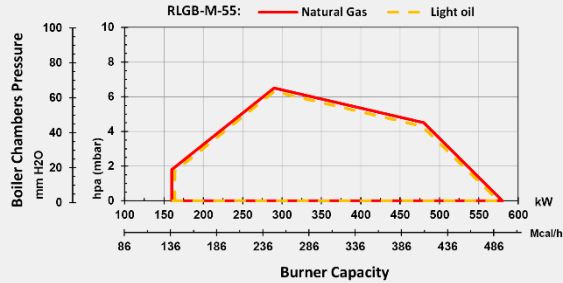

Burner	Capacity (kW)	Turn down
RLGB-M-110	NG: 350-1100	1:3
	LFO: 350-1100	1:3
RLGB-M-145	NG: 400-1380	1:4
	LFO: 400-1380	1:4

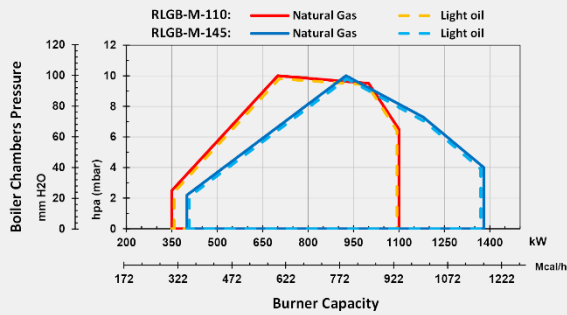

Burner	Capacity (kW)	Turn down
RLGB-M-175/LN	NG: 320-1800	1:5
	LFO: 320-1800	1:5
RLGB-M-205/LN	NG: 450-2200	1:5
	LFO: 450-2200	1:5

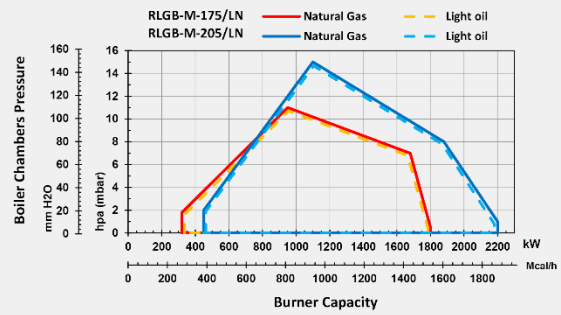

Burner	Capacity (kW)	Turn down
RLGB-M-305/LN	NG: 600-3000	1:5
	LFO: 600-3000	1:5
RLGB-M-385/LN	NG: 650-3500	1:5
	LFO: 650-3500	1:5

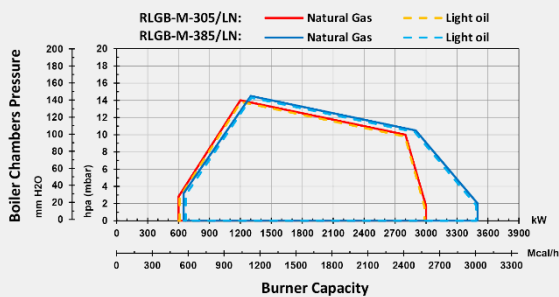

Burner	Capacity (kW)	Turn down
RLGB-M-405/LN	NG: 680-4100	1:6
	LFO: 680-4100	1:6
RLGB-M-505/LN	NG: 700-5100	1:7
	LFO: 700-5100	1:7

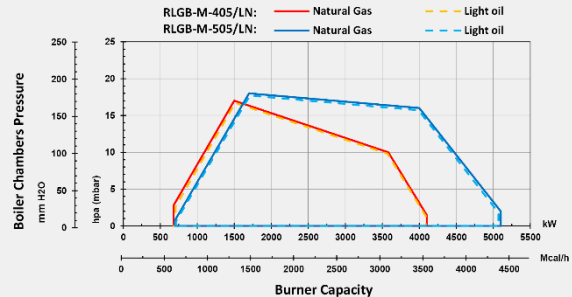

Burner	Capacity (kW)	Turn down
RLGB-M-255	NG: 580-2400 LFO: 580-2400	1:4 1:4

About the working diagram:

The working diagrams for natural gas and light oil fuel oil are certified in accordance with BS-EN 676 and BS-EN 267, respectively.

The firing rate diagram has been obtained considering the ambient temperature of 20°C and atmospheric pressure of 1013 mbar (Sea level condition).

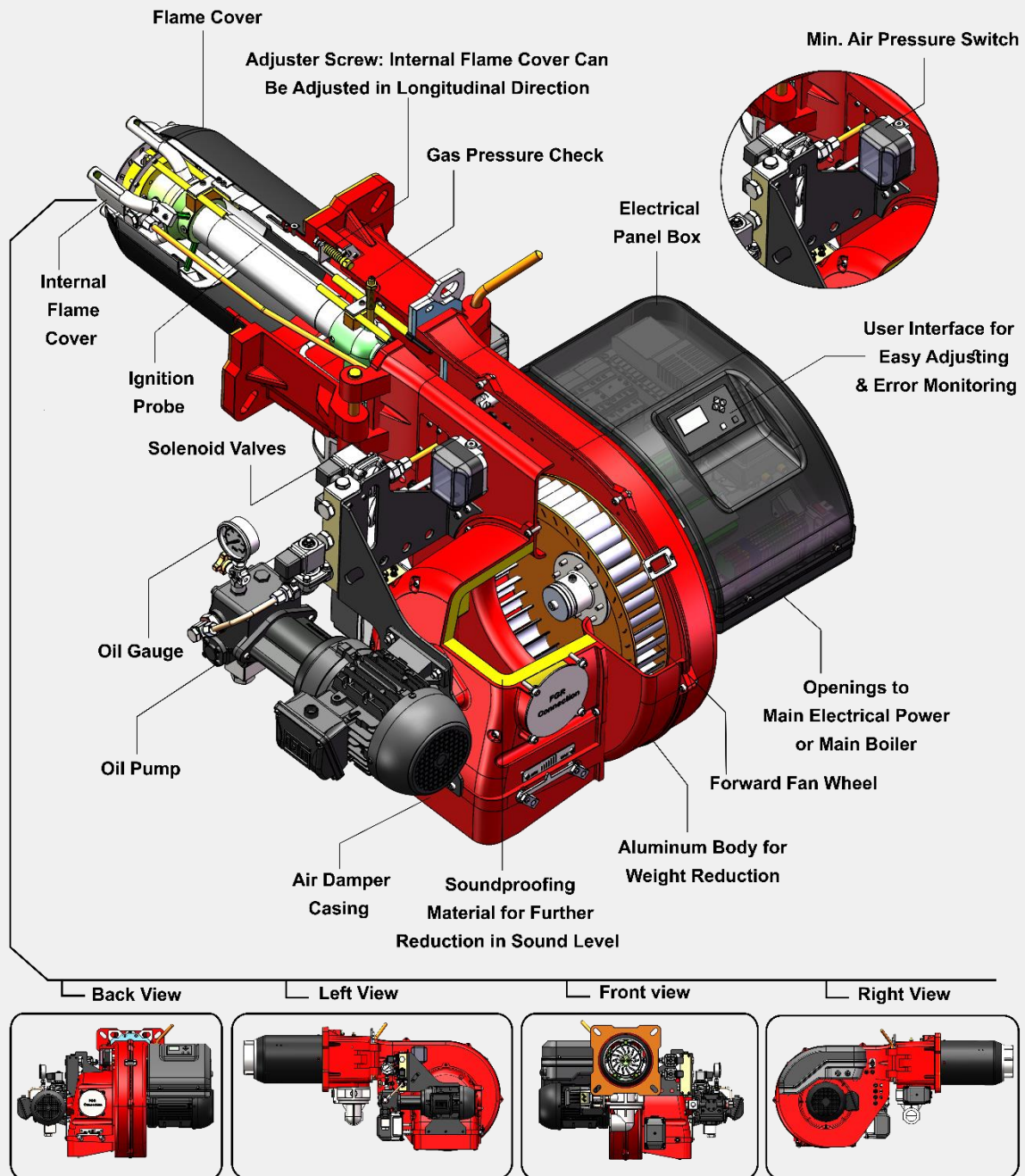
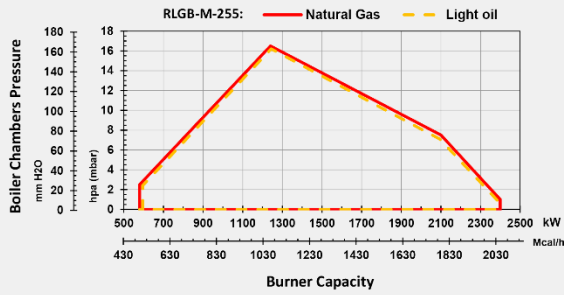





Production Hall of raadman burner Factory- 2023

# General dimension: RLGB-M series

## RLGB-M-55

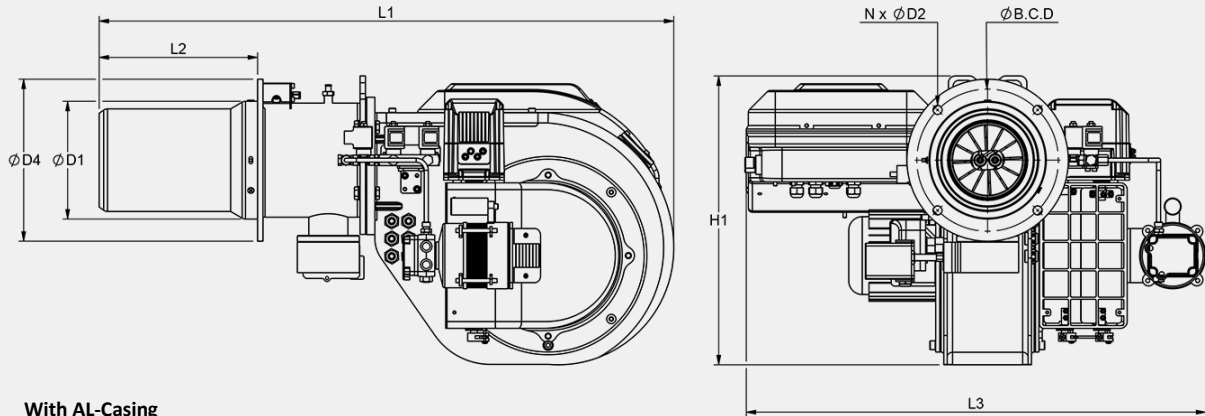

With AL-Casing

Burner Type	L <sub>1</sub>	L <sub>2</sub>	L <sub>3</sub>	H	D <sub>1</sub>	D <sub>2</sub>	D <sub>3</sub>	N	B.C. D
RLGB-M-55	853	235	685	427	179	13.5	240	4	210

## RLGB-M-85

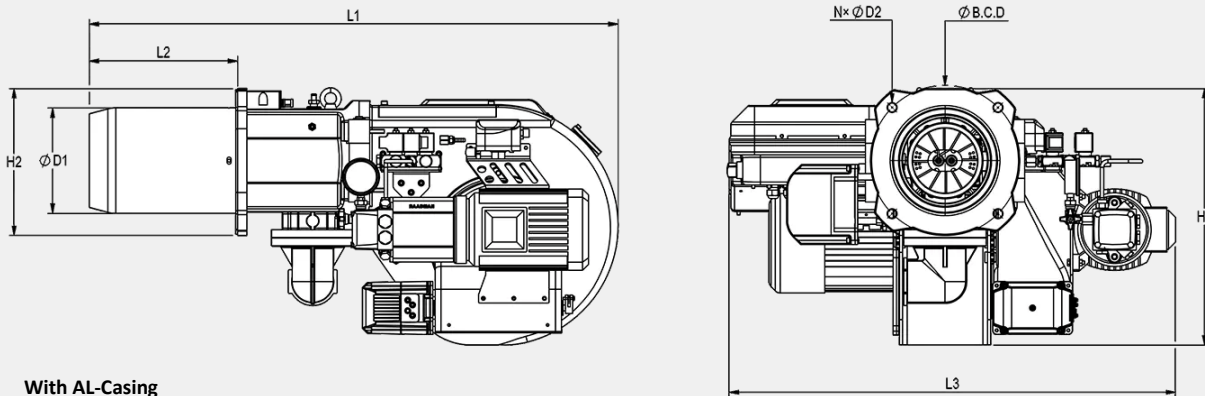

With AL-Casing

Burner Type	L <sub>1</sub>	L <sub>2</sub>	L <sub>3</sub>	H <sub>1</sub>	H <sub>2</sub>	D <sub>1</sub>	D <sub>2</sub>	N	B.C. D
RLGB-M-85	901	253	763	436	250	179	15	4	255



### RLGB-M-110, RLGB-M-145

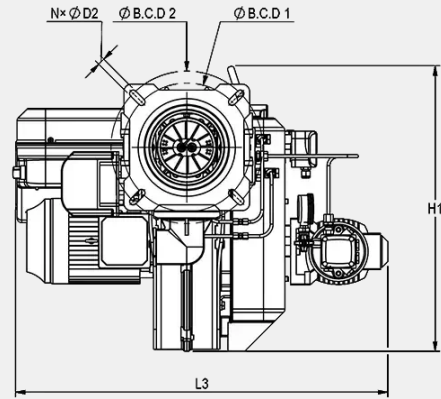
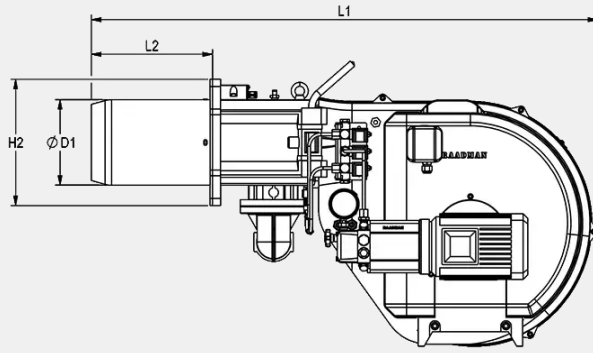

With AL-Casing

Burner Type	L <sub>1</sub>	L <sub>2</sub>	L <sub>3</sub>	H <sub>1</sub>	H <sub>2</sub>	D <sub>1</sub>	D <sub>2</sub>	N	B.C.D.1	B.C.D.2
RLGB-M-110	1068	255	791	598	265	184	15	4	270	320
RLGB-M-145	1068	255	791	598	265	194	15	4	270	320

### RLGB-M-175/LN, RLGB-M-205/LN

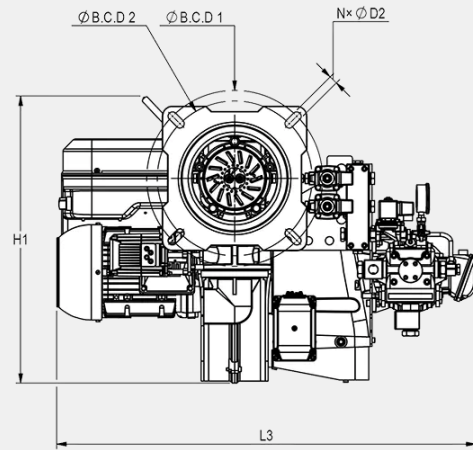
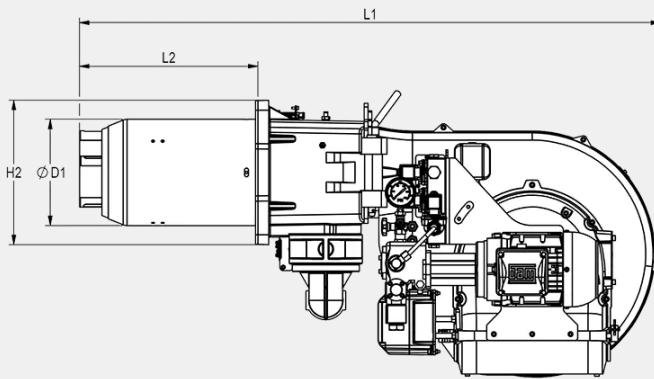

With AL-Casing

Burner Type	L <sub>1</sub>	L <sub>2</sub>	L <sub>3</sub>	H <sub>1</sub>	H <sub>2</sub>	D <sub>1</sub>	D <sub>2</sub>	N	B.C.D.1	B.C.D.2
RLGB-M-175/LN	1213	373	875	598	302	226	18	4	323	367
RLGB-M-205/LN	1213	373	875	598	302	226	18	4	323	367

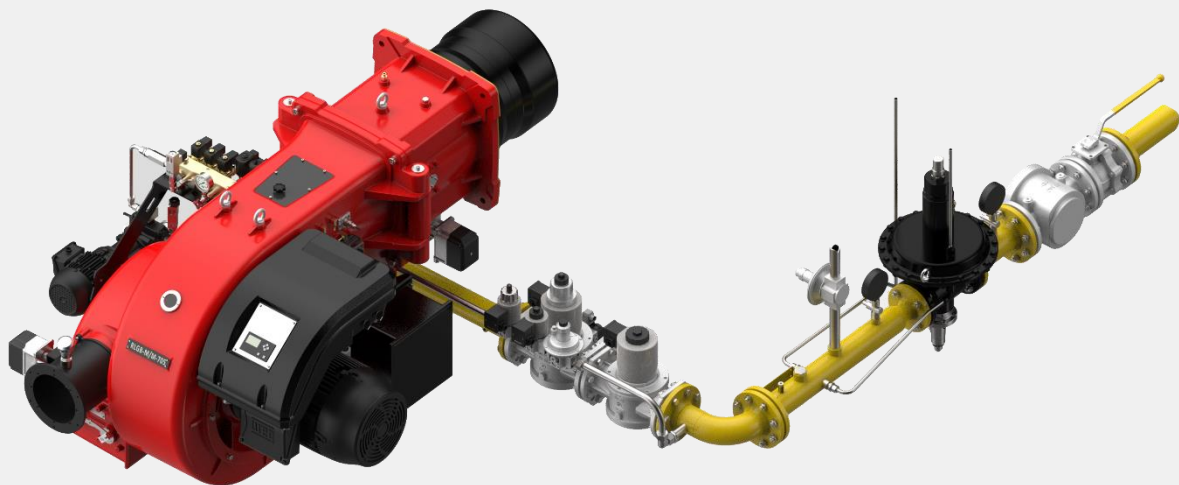



### RLGB-M-255

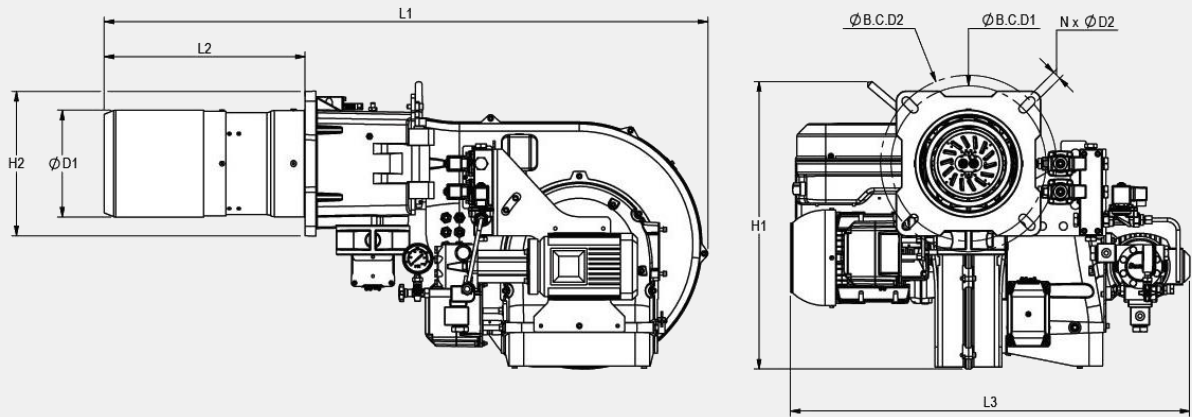

With AL-Casing

Burner Type	L <sub>1</sub>	L <sub>2</sub>	L <sub>3</sub>	H <sub>1</sub>	H <sub>2</sub>	D <sub>1</sub>	D <sub>2</sub>	N	B.C.D1	B.C.D2
RLGB-M-255	1260	419	833	598	302	223	18	4	323	367

### RLGB-M-305/LN, RLGB-M-385/LN, RLGB-M-405/LN, RLGB-M-505/LN, RLGB-M-605/LN

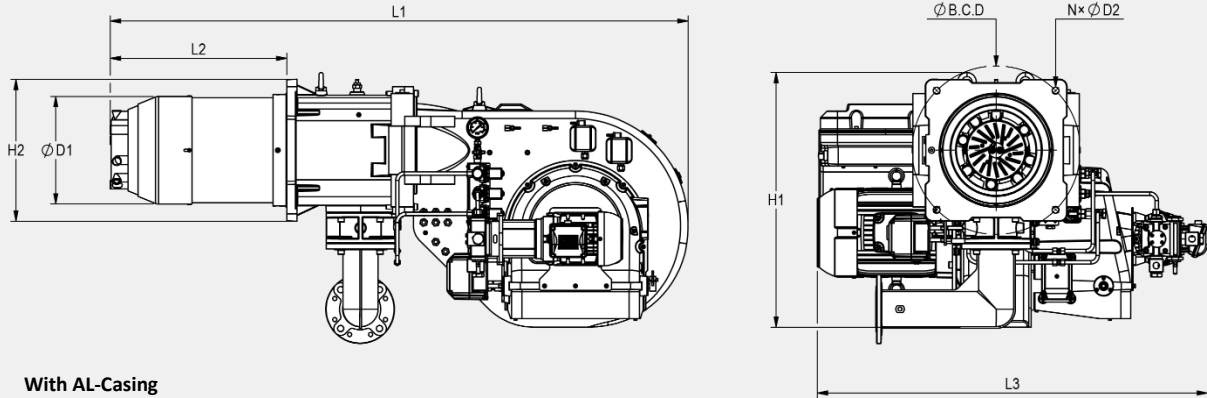

With AL-Casing

Burner Type	L <sub>1</sub>	L <sub>2</sub>	L <sub>3</sub>	H <sub>1</sub>	H <sub>2</sub>	D <sub>1</sub>	D <sub>2</sub>	N	B.C. D
RLGB-M-305/LN	1683	514	1137	741	413	328	20	4	490
RLGB-M-385/LN	1683	514	1137	741	413	328	20	4	490
RLGB-M-405/LN	1683	514	1249	741	413	328	20	4	490
RLGB-M-505/LN	1683	514	1249	741	413	328	20	4	490
RLGB-M-605/LN	1680	512	1245	741	413	340	20	4	490



## Technical data: RLGB-M series

- N.G operation: Electronic Modular
- LFO operation: II or III Stage

Burner	Power system		Power management system			
	Motor(kW/PH/V/HZ/rpm)	Controller		Actuator(N.M)		
		Brand	Mode	Air	Fuel	Head
RLGB-M-55	0.75 /3 /380-400 /50 /2840	LAMTEC	BT340	1.2	0.8	--
RLGB-M-85	1.1 /3 /380-400 /50 /2840	LAMTEC	BT340	1.2	1.2	--
RLGB-M-110	1.5 /3 /380-400 /50 /2840	LAMTEC	BT340	1.2	1.2	--
		SIEMENS	LMV2...			
RLGB-M-145	2.2 /3 /380-400 /50 /2840	LAMTEC	BT340	3	1.2	--
		SIEMENS	LMV2...			
RLGB-M-175/LN	4 /3 /380-400 /50 /2840	LAMTEC	BT340	3	1.2	--
		SIEMENS	LMV2...			
RLGB-M-205/LN	5.5 /3 /380-400 /50 /2840	LAMTEC	BT340	3	1.2	--
		SIEMENS	LMV2...			
RLGB-M-255	5.5 /3 /380-400 /50 /2840	LAMTEC	BT340	3	1.2	--
		SIEMENS	LMV2...			
RLGB-M-305/LN	7.5 /3 /380-400 /50 /2940	LAMTEC	BT340	3	1.2	--
		SIEMENS	LMV2...			
RLGB-M-385/LN	7.5 /3 /380-400 /50 /2940	LAMTEC	BT340	3	1.2	--
		SIEMENS	LMV2...			
RLGB-M-405/LN	11 /3 /380-400 /50 /2940	LAMTEC	BT340	9	1.2	--
		SIEMENS	LMV2...	10		
RLGB-M-505/LN	11 /3 /380-400 /50 /2940	LAMTEC	BT340	9	1.2	--
		SIEMENS	LMV2...	10		
RLGB-M-605/LN	15 /3 /380-400 /50 /2940	LAMTEC	BT340	9	1.2	--
		SIEMENS	LMV2...	10		









# raadman RLGB-M/M series burner

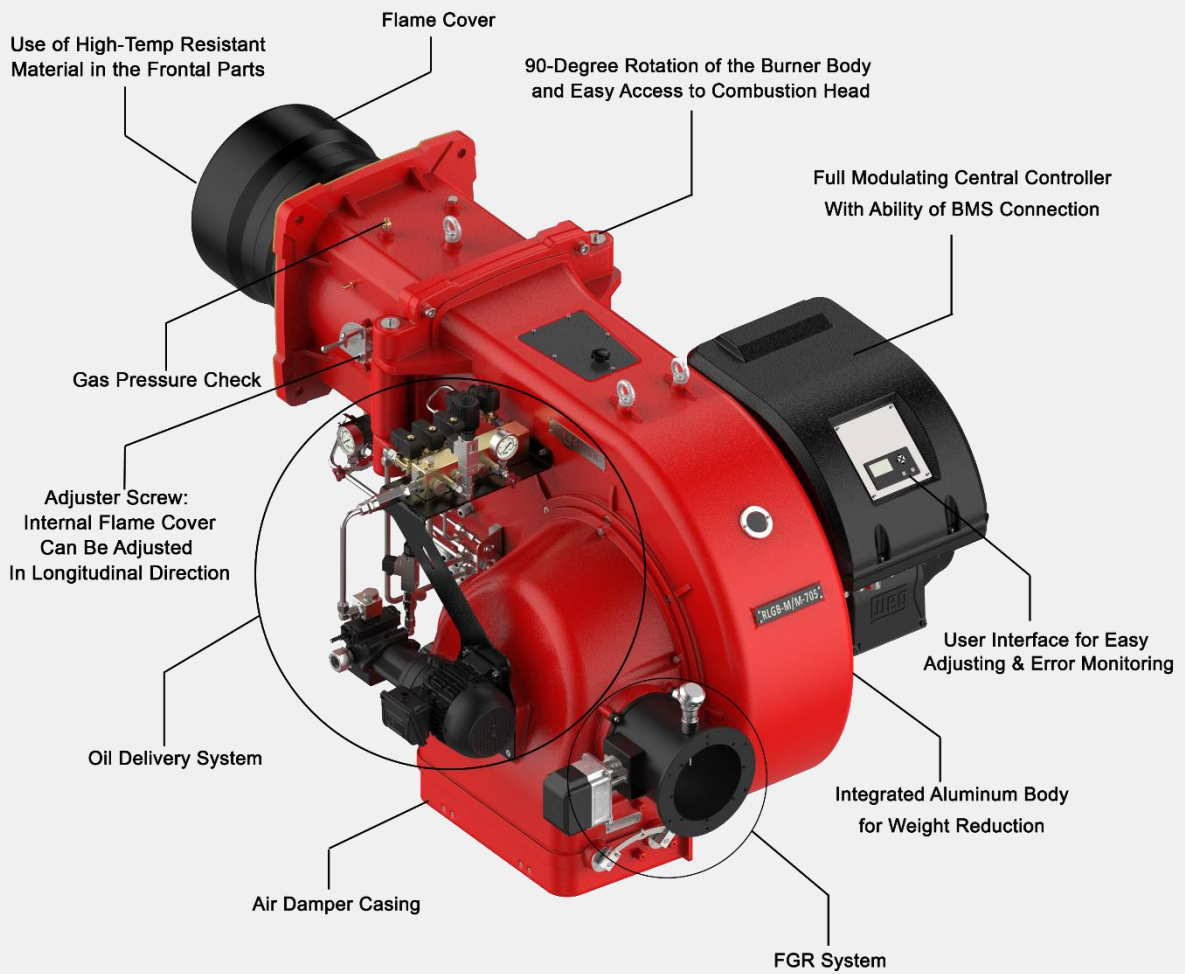

# Burner selection: capacity and working diagram

## Modulating Dual-Fuel Burner

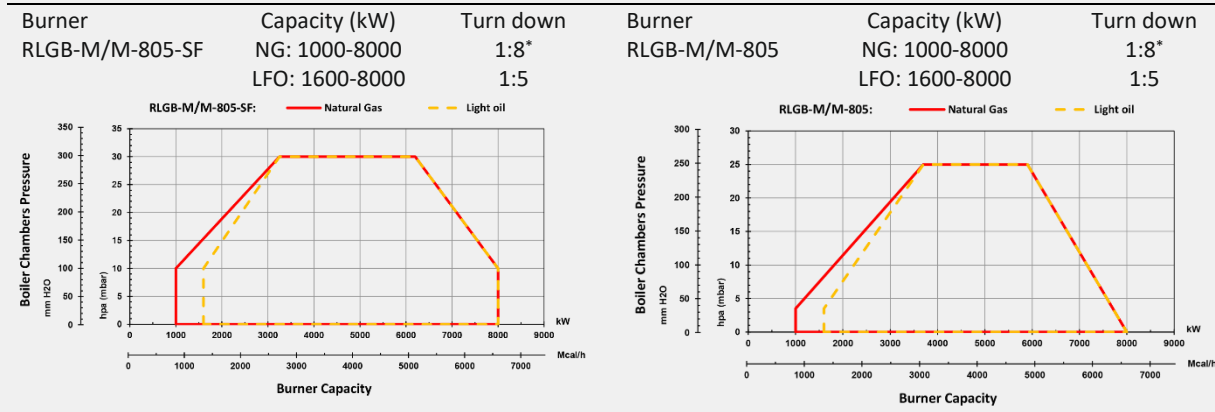
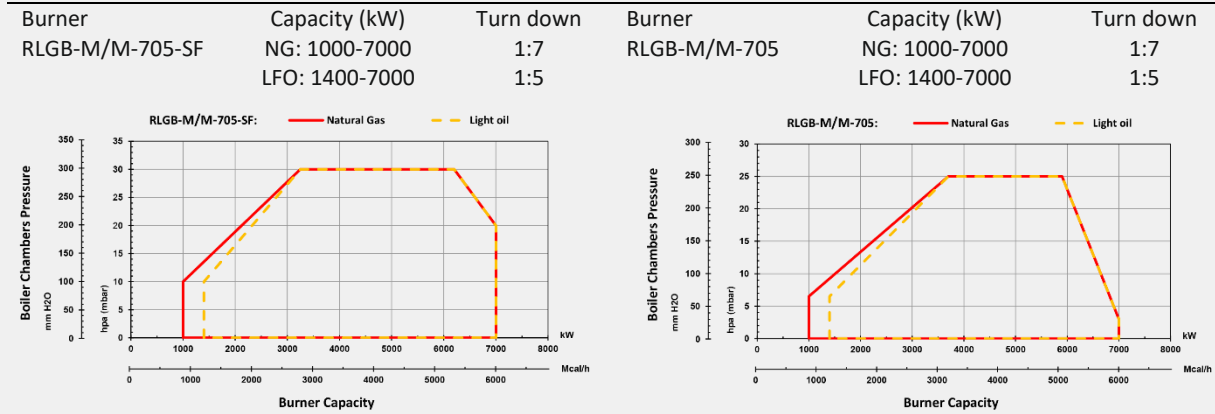
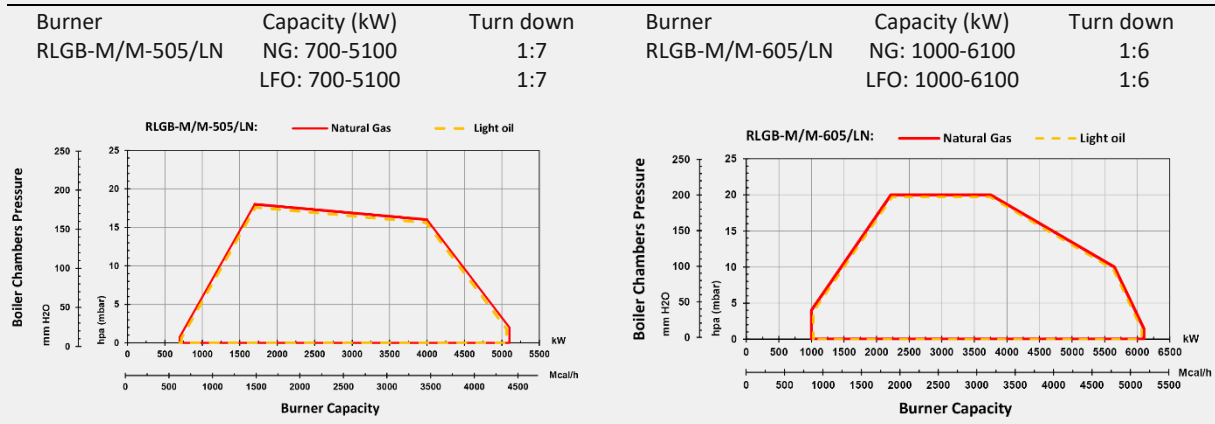
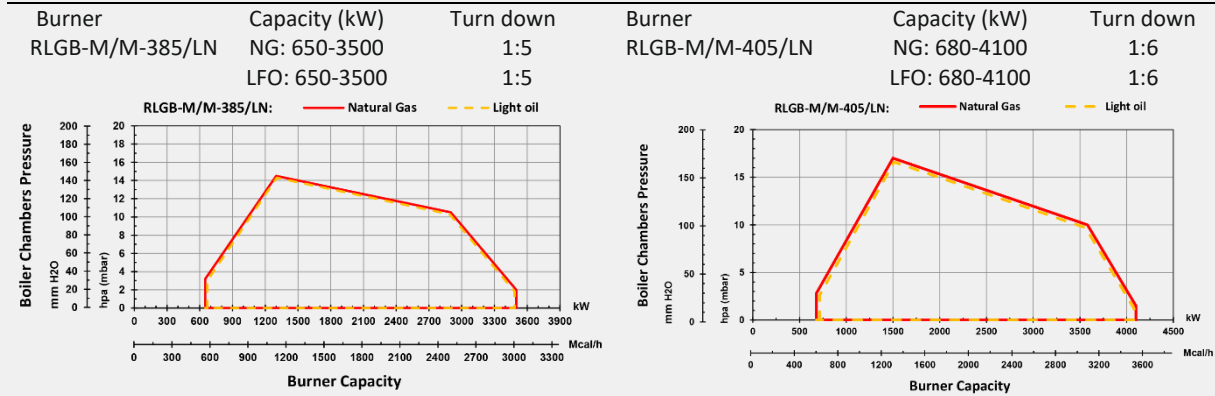



Burner	Capacity (kW)	Turn down
RLGB-M/M-950	NG: 1000-9000 LFO: 1800-9000	1:9* 1:5

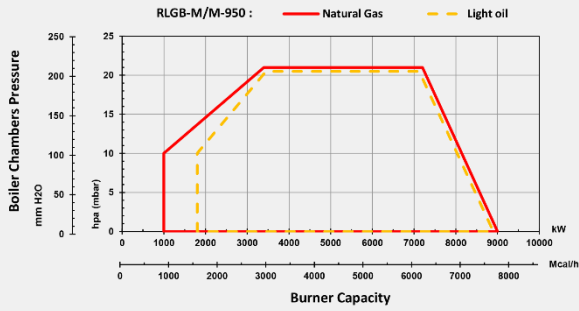

Burner	Capacity (kW)	Turn down
RLGB-M/M-1050	NG: 1000-10500 LFO: 2000-10500	1:10* 1:5

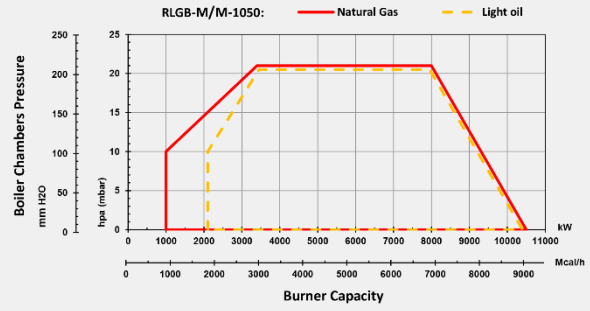

Burner	Capacity (kW)	Turn down
RLGB-M/M-1250	NG: 1200-12000 LFO: 2400-12000	1:10* 1:5

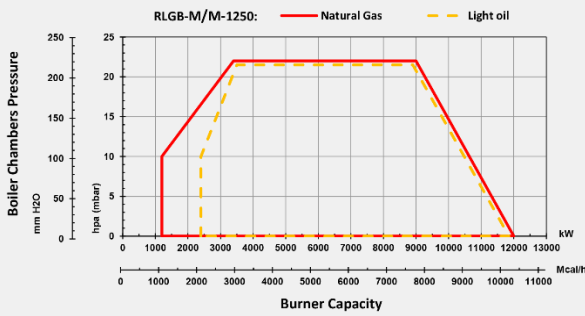

Burner	Capacity (kW)	Turn down
RLGB-M/M-1350	NG: 1350-13500 LFO: 2600-13000	1:10 1:5

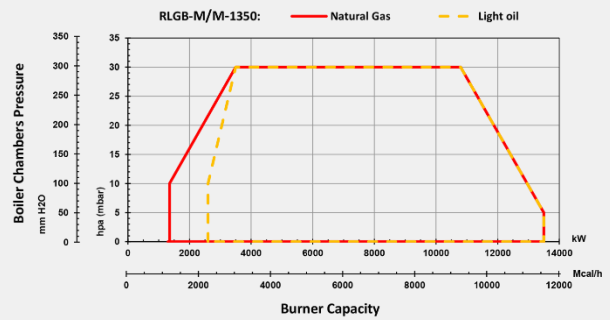

Burner	Capacity (kW)	Turn down
RLGB-M/M-1550	NG: 1900-15000 LFO: 3100-15000	1:8* 1:5

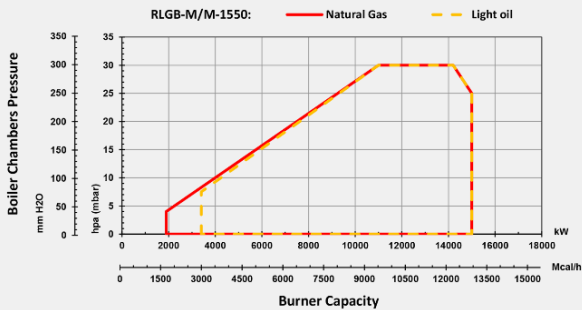

Burner	Capacity (kW)	Turn down
RLGB-M/M-1750	NG: 2200-17500 LFO: 3500-17000	1:8* 1:5

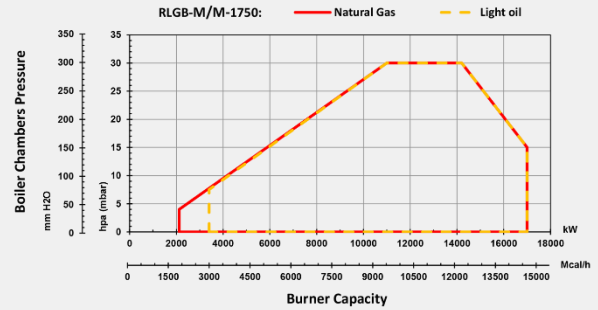

Burner	Capacity (kW)	Turn down
RLGB-M/M-2250	NG: 2750-22000 LFO: 4400-22000	1:8* 1:5

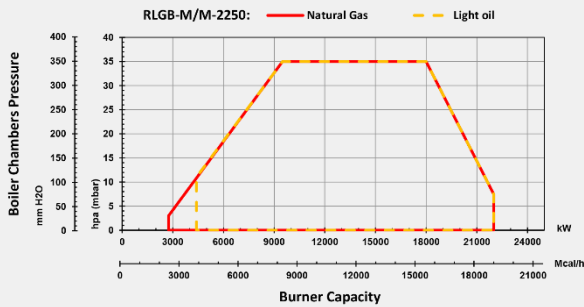

Burner	Capacity (kW)	Turn down
RLGB-M/M-2550	NG: 3125-25000 LFO: 5000-23700	1:8* 1:5

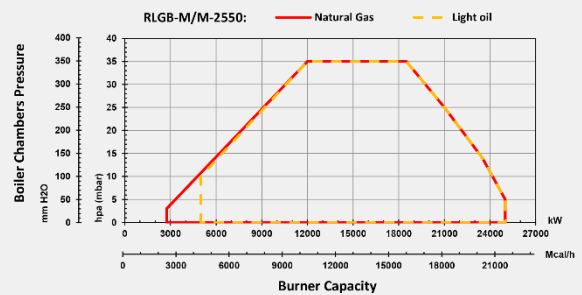

\*Special note: Turn-down ratio higher than (1:8, 1:9, 1:10, etc.) are accessible for the burner with the head actuator. Otherwise, without a head actuator, the maximum turn-down ratio is 1:6.



# General dimension: RLGB-M/M series

RLGB-M/M-385/LN, RLGB-M/M-405/LN, RLGB-M/M-505/LN, RLGB-M/M-605/LN

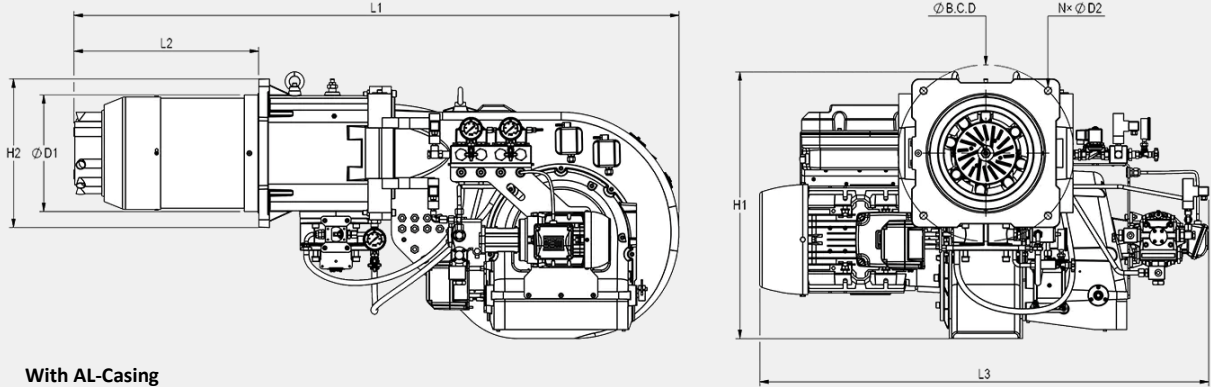

With AL-Casing

Burner Type	L <sub>1</sub>	L <sub>2</sub>	L <sub>3</sub>	H <sub>1</sub>	H <sub>2</sub>	D <sub>1</sub>	D <sub>2</sub>	N	B.C. D
RLGB-M/M-385/LN	1683	514	1140	741	413	328	20	4	490
RLGB-M/M-405/LN	1683	514	1141	741	413	328	20	4	490
RLGB-M/M-505/LN	1683	514	1141	741	413	328	20	4	490
RLGB-M/M-605/LN	1680	512	1246	741	413	340	20	4	490

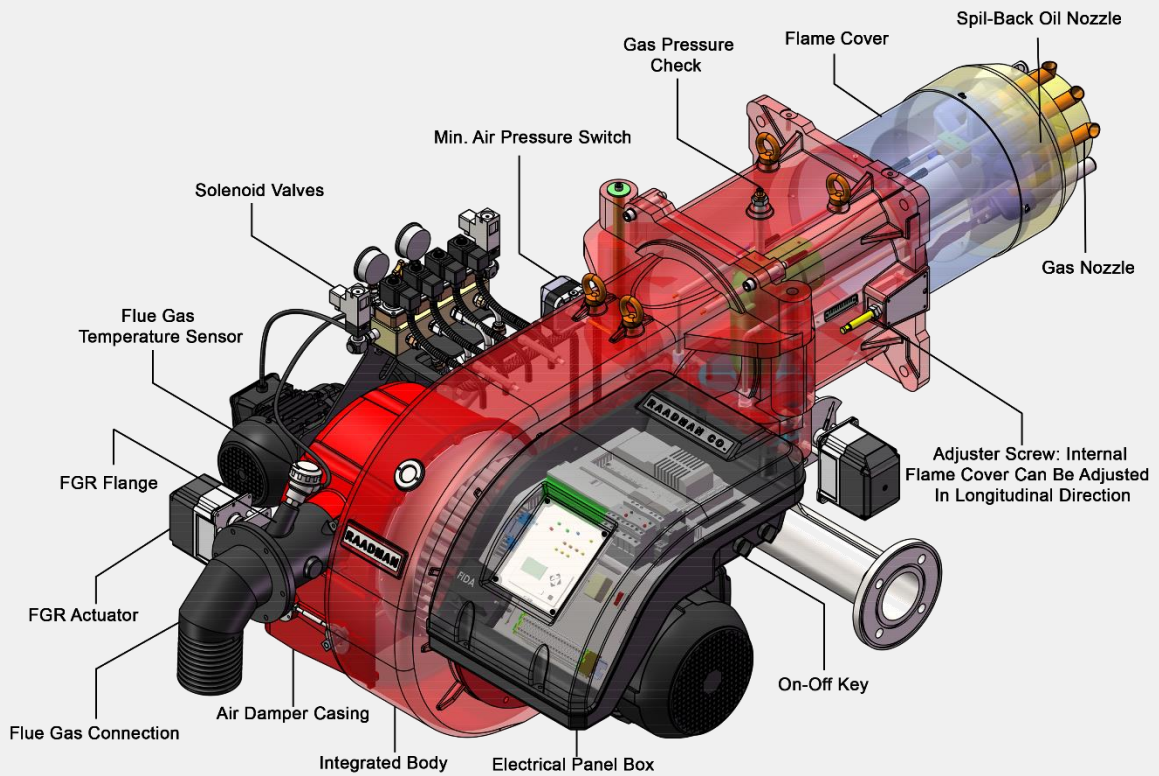

**RLGB-M/M-705-SF, RLGB-M/M-705, RLGB-M/M-950, RLGB-M/M-1050**

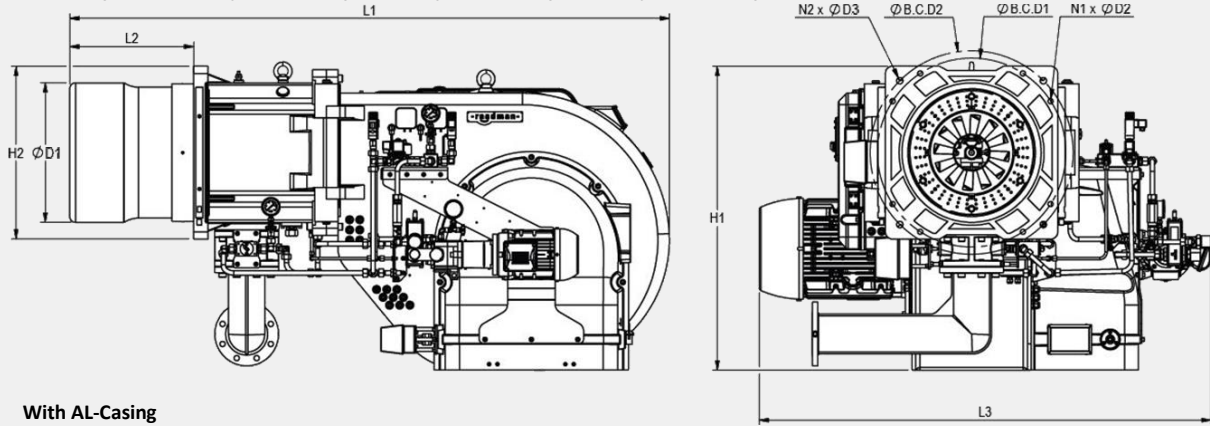

With AL-Casing

Burner Type	L <sub>1</sub>	L <sub>2</sub>	L <sub>3</sub>	H <sub>1</sub>	H <sub>2</sub>	D <sub>1</sub>	D <sub>2</sub>	D <sub>3</sub>	N <sub>1</sub>	N <sub>2</sub>	B.C.D1 <sup>*</sup>	B.C.D2 <sup>*</sup>
RLGB-M/M-705-SF	1816	350	1415	955	502	400	----	22	--	4	----	590
RLGB-M/M-705	1886	420	1415	955	502	400	----	22	--	4	----	590
RLGB-M/M-950	2069	428	1559	1046	595	480	17.5	22	8	4	650	700
RLGB-M/M-1050	2069	428	1559	1046	595	480	17.5	22	8	4	650	700

**RLGB-M/M-705-SF, RLGB-M/M-705, RLGB-M/M-805-SF, RLGB-M/M-805, RLGB-M/M-950, RLGB-M/M-1050**

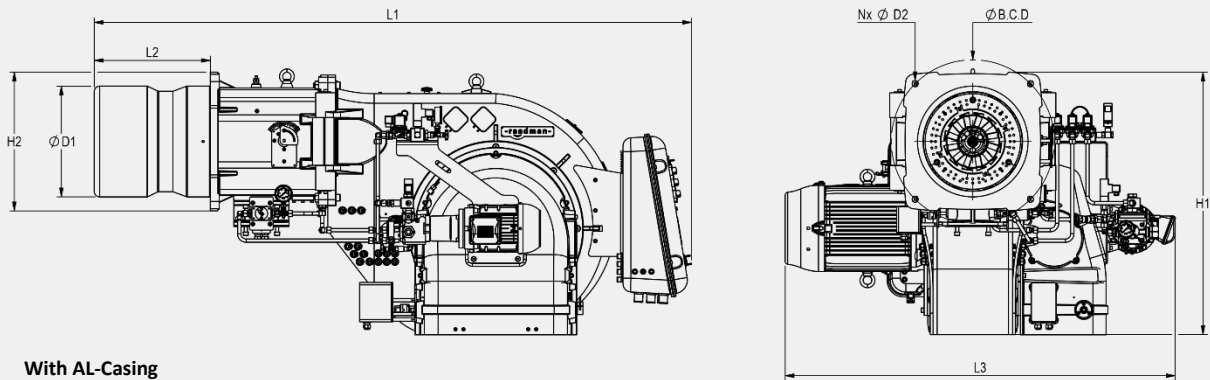

With AL-Casing

Burner Type	L <sub>1</sub>	L <sub>2</sub>	L <sub>3</sub>	H <sub>1</sub>	H <sub>2</sub>	D <sub>1</sub>	D <sub>2</sub>	D <sub>3</sub>	N <sub>1</sub>	N <sub>2</sub>	B.C.D1 <sup>*</sup>	B.C.D2 <sup>*</sup>
RLGB-M/M-705-SF	2075	350	1415	955	502	400	----	22	--	4	----	590
RLGB-M/M-705	2195	420	1457	955	502	400	----	22	--	4	----	590
RLGB-M/M-805-SF	2075	350	1415	955	502	400	----	22	--	4	----	590
RLGB-M/M-805	2195	420	1457	955	502	400	----	22	--	4	----	590
RLGB-M/M-950	2375	428	1559	1046	595	480	17.5	22	8	4	650	700
RLGB-M/M-1050	2375	428	1559	1046	595	480	17.5	22	8	4	650	700

**RLGB-M/M-950, RLGB-M/M-1050, RLGB-M/M-1250, RLGB-M/M-1350 RLGB-M/M-1550, RLGB-M/M-1750, RLGB-M/M-2250, RLGB-M/M-2550**

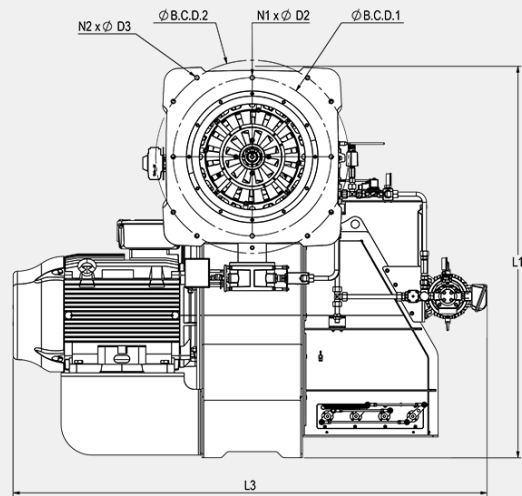
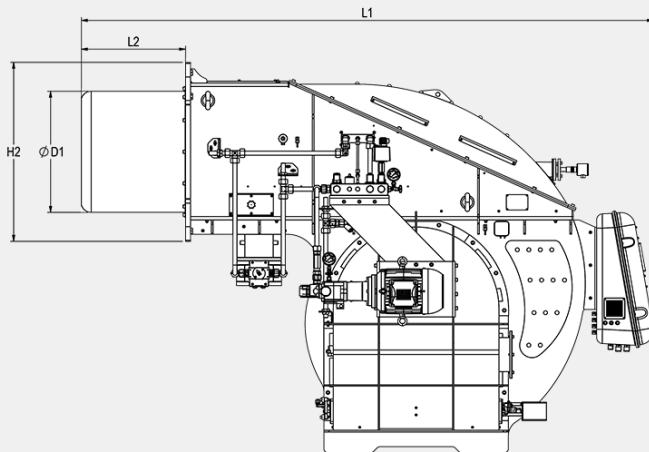

With Carbon-Steel Casing

Burner Type	L <sub>1</sub>	L <sub>2</sub>	L <sub>3</sub>	H <sub>1</sub>	H <sub>2</sub>	D <sub>1</sub>	D <sub>2</sub>	D <sub>3</sub>	N <sub>1</sub>	N <sub>2</sub>	B.C.D1*	B.C.D2*
RLGB-M/M-950	2069	428	1545	1326	613	480	17.5	22	8	4	650	700
RLGB-M/M-1050	2069	428	1545	1326	613	480	17.5	22	8	4	650	700
RLGB-M/M-1250	2008	367	1625	1324	613	480	17.5	22	8	4	650	700
RLGB-M/M-1350	2258	367	1625	1700	660	480	20	20	4	4	590	790
RLGB-M/M-1550	2585	510	1918	1822	872	590	20	20	4	8	770	940
RLGB-M/M-1750	2585	510	1918	1822	872	590	20	20	4	8	770	940
RLGB-M/M-2250	2790	508	2212	1906	872	590	20	20	4	8	770	940
RLGB-M/M-2550	2790	508	2212	1906	872	590	20	20	4	8	770	940

\* Note: For the hole patterns of the burner flange, kindly refer to the burner technical proposals while placing an order.



## Technical data: RLGB-M/M series

- N.G operation: Electronic Modular
- LFO operation: Electronic Modular

Power system		Power management system				
Burner	Motor(kW/PH/V/HZ/rpm)	Controller		Actuator (N.M)		
		Brand	Name	Air	Fuel	Head*
RLGB-M/M-385/LN	7.5 /3/380-400 /50 /2840	LAMTEC	BT340	3	3	--
		SIEMENS	LMV26			
RLGB-M/M-405/LN	11 /3 /380-400 /50 /2840	LAMTEC	BT340	9	3	--
		SIEMENS	LMV26	10		
RLGB-M/M-505/LN	11 /3/380-400 /50 /2840	LAMTEC	BT340	9	3	--
		SIEMENS	LMV26	10		
RLGB-M/M-605/LN	15 /3/380-400 /50 /2840	LAMTEC	BT340	9	3	--
		SIEMENS	LMV26	10		
RLGB-M/M-705-SF RLGB-M/M-705	18.5/3/380-400 /50 /2840	LAMTEC	BT340	9	3	--
		AUTOFLAME	MINI MK8	25	4	
RLGB-M/M-805-SF	18.5 /3 /380-400 /50 /2840	AUTOFLAME	MINI MK8	25	4	--
RLGB-M/M-805	22 /3 /380-400 /50 /2840	AUTOFLAME	MINI MK8	25	4	--
RLGB-M/M-950	22/3/380-400 /50 /2840	LAMTEC	ETAMATIC-OEM	20	6	20
		SIEMENS	LMV5...	20	3	20
		AUTOFLAME	MINI MK8	25	4	25
RLGB-M/M-1050	22/3/380-400 /50 /2840	LAMTEC	ETAMATIC-OEM	20	6	20
		SIEMENS	LMV5...	20	3	20
		AUTOFLAME	MINI MK8	25	4	25
RLGB-M/M-1250	30/3/380-400 /50 /2840	LAMTEC	ETAMATIC-OEM	20	6	20
		SIEMENS	LMV5...	20	20	20
		AUTOFLAME	MINI MK8	25	4	25
RLGB-M/M-1350	37/3/380-400 /50 /2840	LAMTEC	ETAMATIC-OEM	20	6	20
		SIEMENS	LMV5...	20	20	20
		AUTOFLAME	MINI MK8	25	25	25
RLGB-M/M-1550	45/3/380-400 /50 /2900	LAMTEC	ETAMATIC-OEM	20	20	20
		SIEMENS	LMV5...	20	20	20
		AUTOFLAME	MINI MK8	25	25	25
RLGB-M/M-1750	45/3/380-400 /50 /2900	LAMTEC	ETAMATIC-OEM	20	20	20
		SIEMENS	LMV5	20	20	20
		AUTOFLAME	MINI MK8	25	25	25
RLGB-M/M-2250	75/3/380-400 /50 /2900	LAMTEC	ETAMATIC-OEM	40	20	40
		SIEMENS	LMV5	35	20	35
		AUTOFLAME	MINI MK8	25	25	40
RLGB-M/M-2550	75/3/380-400 /50 /2900	LAMTEC	ETAMATIC-OEM	40	20	40
		SIEMENS	LMV5	35	20	35
		AUTOFLAME	MINI MK8	25	25	40

\*Optional, note: Using combustion head actuator is necessary in burners with capacity of 15 mW and higher.





RL63-VN-950

CAUTION  
High Voltage  
Personal Safety

Control panel with digital display and buttons

RAADMAN  
RAADMAN  
Manufacture of industrial  
pumps, tanks and heat exchangers  
Look to the future

- raadman -



# Gas train diagram

**GT1 (Pressure input < 360 mbar, separated items)**

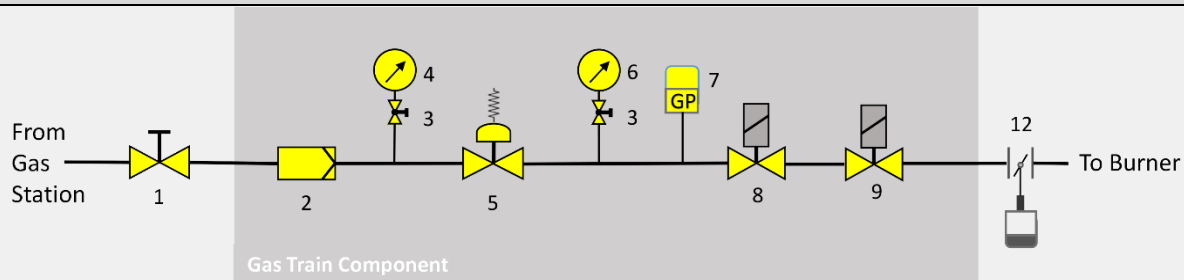

**GT2 (Pressure input < 360 mbar, multi bloc gas train)**

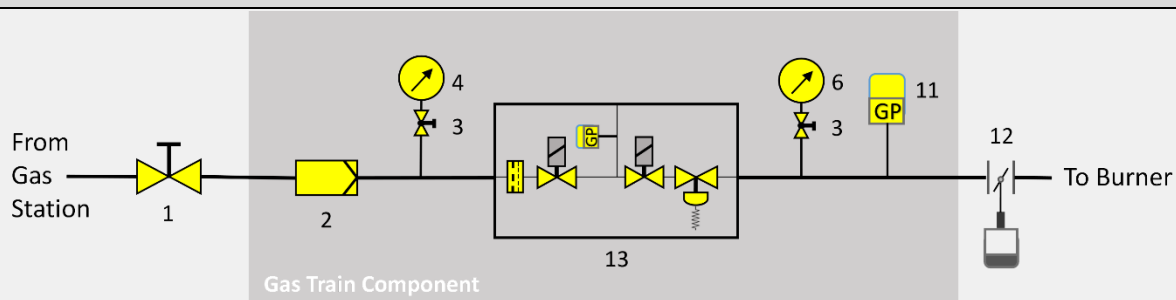

**GT3 (Pressure input < 360 mbar, separated gas train, with pilot)**

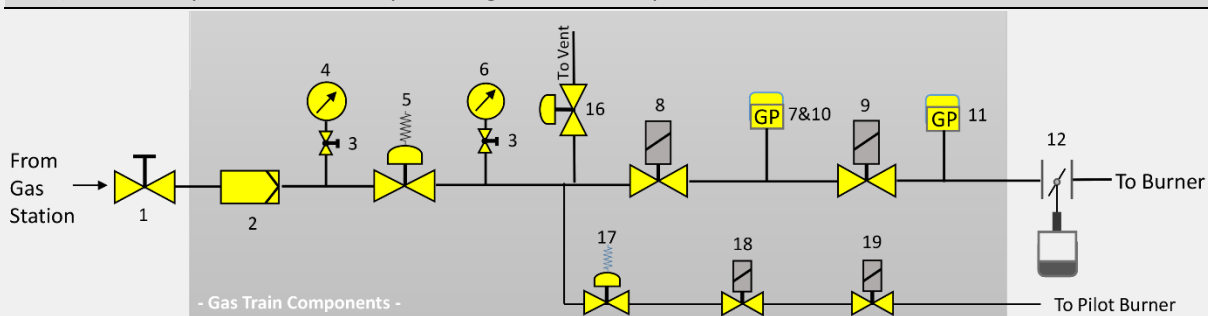

**GT4 (Pressure input < 360 mbar, multi block gas train, with pilot)**

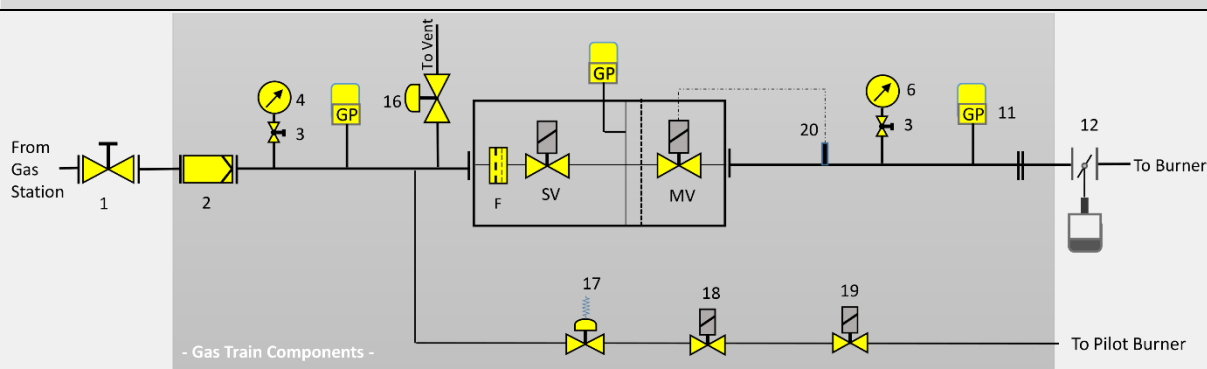



**GT5 (Pressure input > 360 mbar, separated gas train, with pilot)**

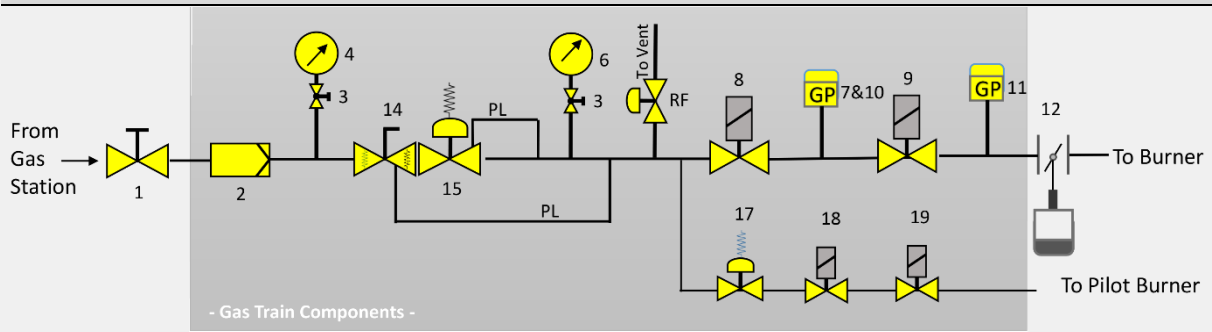

**GT6 (Pressure input > 360 mbar, multi block gas train, with pilot)**

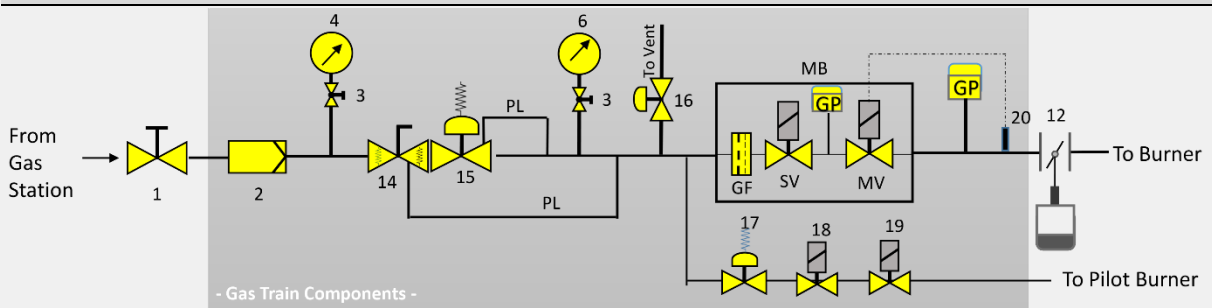

- |                                      |                                   |                             |
|--------------------------------------|-----------------------------------|-----------------------------|
| 1: Ball valve                        | 8: Safety gas valve               | 15: High pressure regulator |
| 2: Gas filter                        | 9: Main gas valve                 | 16: Relief valve            |
| 3: Push button valve                 | 10: Leak Test gas pressure switch | 17: Pilot regulator         |
| 4: Pressure Gauge                    | 11: Max. gas pressure switch      | 18: Pilot valve 1           |
| 5: Pressure regulator (Low-pressure) | 12: Butterfly valve               | 19: Pilot valve 2           |
| 6: Pressure Gauge                    | 13: Multi-Block Solenoid Valve    | 20: Pressure transmitter    |
| 7: Min. gas pressure switch          | 14: Shut-off valve                |                             |

## Gas train size

RGB-M Series				
Burner	Gas model	Gas train size	$\Delta P B. V$	$\Delta P C.H^*$ (mbar)
RGB-M-55	GT-1	Rp 1 ½	2	7.2
	GT-2	Rp 1 ½		
RGB-M-80	GT-1	Rp 1 ½	2	10.3
	GT-2	Rp 1 ½		
RGB-M-85/LN	GT-1	Rp 1 ½	2	11.7
	GT-2	Rp 1 ½		
RGB-M-110	GT-1	Rp 1 ½	2	9
	GT-2	Rp 1 ½		
RGB-M-130/LN	GT-1	Rp 1 ½	2	22.5
	GT-2	Rp 1 ½		
RGB-M-145	GT-1	Rp 2	2	8.6
	GT-2	Rp 2		
RGB-M-175/LN	GT-1	Rp 2	3	17
	GT-2	Rp 2		
RGB-M-185	GT-1	Rp 2	3	14.5
	GT-2	Rp 2		
RGB-M-205	GT-1	Rp 2	3	14.5
	GT-2	Rp 2		
RGB-M-255/LN	GT-1	DN65	3	24.9
	GT-2	Rp 2		
RGB-M-305	GT-1	DN65	4	20.6
	GT-2	Rp 2		
RGB-M-385	GT-1	DN80	4	31.7
	GT-2	DN65		
RGB-M-405/LN	GT-1	DN80	4	47
	GT-2	DN65		
RGB-M-505/LN	GT-1	DN80	4	56
	GT-2	DN65		
RGB-M-605	GT-1	DN80	4	62.8
	GT-2	DN65		
RGB-M-705-SF	GT-3	DN100	4	78
	GT-4	DN80		
RGB-M-705	GT-3	DN100	4	85
	GT-4	DN80		
RGB-M-805-SF	GT-3	DN100	5	90
	GT-4	DN80		
RGB-M-805	GT-3	DN100	5	95
	GT-4	DN80		
RGB-M-950	GT-3	DN100	5	85
	GT-4	DN80		
	GT-5	DN80		
RGB-M-1050	GT-3	DN100	5	110
	GT-4	DN100		
	GT-5	DN100		
RGB-M-1250	GT-5	DN100	5	85
	GT-6	DN100		
RGB-M-1350	GT-4	DN100	6	100
	GT-5	DN100		
	GT-6	DN100		

\*Combustion head,

<b>RGB-M Series</b>				
<b>Burner</b>	<b>Gas model</b>	<b>Gas train size</b>	<b>ΔP B. V</b>	<b>ΔP C.H* (mbar)</b>
RGB-M-1550	GT-4	DN100	7	110
	GT-5	DN100		
	GT-6	DN100		
RGB-M-1750	GT-4	DN100	7	125
	GT-5	DN100		
	GT-6	DN100		
RGB-M-2250	GT-5	DN125	15	165
	GT-5	DN125		
	GT-6	DN100		
RGB-M-2550	GT-4	DN125	17	160
	GT-5	DN125		
	GT-6	DN100		

<b>RLGB-M Series</b>				
<b>Burner</b>	<b>Gas model</b>	<b>Gas train size</b>	<b>ΔP B. V</b>	<b>ΔP C.H* (mbar)</b>
RLGB-M-55	GT-1	Rp 1 ½	2	14
	GT-2	Rp 1 ½		
RLGB-M-85	GT-1	Rp 1 ½	2	6.2
	GT-2	Rp 1 ½		
RLGB-M-110	GT-1	Rp 2	2	9
	GT-2	Rp 2		
RLGB-M-145	GT-1	Rp 2	2	13
	GT-2	Rp 2		
RLGB-M-175/LN	GT-1	Rp 2	3	17
	GT-2	Rp 2		
RLGB-M-205/LN	GT-1	DN65	3	21.5
	GT-2	Rp 2		
RLGB-M-255/LN	GT-1	DN65	3	27.8
	GT-2	Rp 2		
RLGB-M-305/LN	GT-1	DN65	4	23
	GT-2	Rp 2		
RLGB-M-385/LN	GT-1	DN80	4	27.3
	GT-2	DN65		
RLGB-M-405/LN	GT-1	DN80	4	44
	GT-2	DN65		





RLGB-M/M Series				
Burner	Gas model	Gas train size	$\Delta P B. V$	$\Delta P C.H^*$ (mbar)
RLGB-M/M-385/LN	GT-1	DN65	4	31.4
	GT-2	DN65		
RLGB-M/M-405/LN	GT-1	DN80	4	47
	GT-2	DN65		
RLGB-M/M-505/LN	GT-1	DN80	4	56
	GT-2	DN65		
RLGB-M/M-605/LN	GT-1	DN80	4	62.8
	GT-2	DN65		
RLGB-M/M-705-SF	GT-3	DN100	4	78
	GT-5	DN80		
RLGB-M/M-705	GT-3	DN100	5	85
	GT-5	DN80		
RLGB-M/M-805-SF	GT-3	DN100	5	90
	GT-5	DN80		
RLGB-M/M-805	GT-3	DN100	5	95
	GT-5	DN80		
RLGB-M/M-950	GT-3	DN100	5	85
	GT-5	DN80		
RLGB-M/M-1050	GT-3	DN100	5	110
	GT-4	DN80		
RLGB-M/M-1250	GT-5	DN100	5	85
	GT-6	DN100		
RLGB-M/M-1350	GT-4	DN100	6	100
	GT-6	DN100		
RLGB-M/M-1550	GT-4	DN100	7	110
	GT-6	DN100		
RLGB-M/M-1750	GT-4	DN100	7	125
	GT-6	DN100		
RLGB-M/M-2250	GT-4	DN125	15	165
	GT-6	DN100		
RLGB-M/M-2550	GT-4	DN125	17	155
	GT-6	DN100		

\*Combustion head

**Special Note:** The above gas train sizes are proposed based on customer's requests and limits of the projects while placing an order. Therefore, we kindly ask the readers that assume this information as an initial and most likely offers.





Wind Tunnel- raadman Burner Factory

- raadman -





# Emission

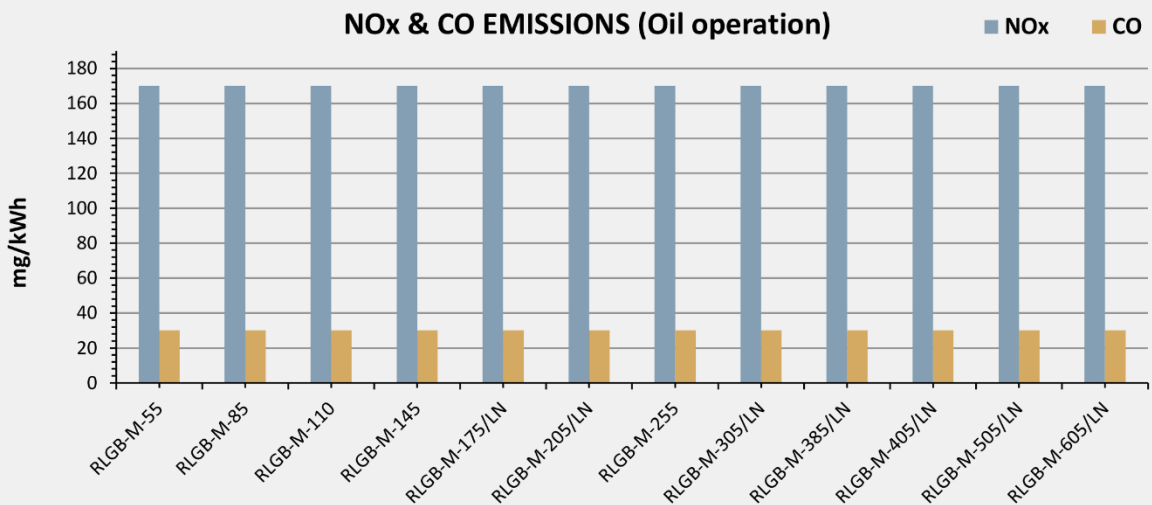
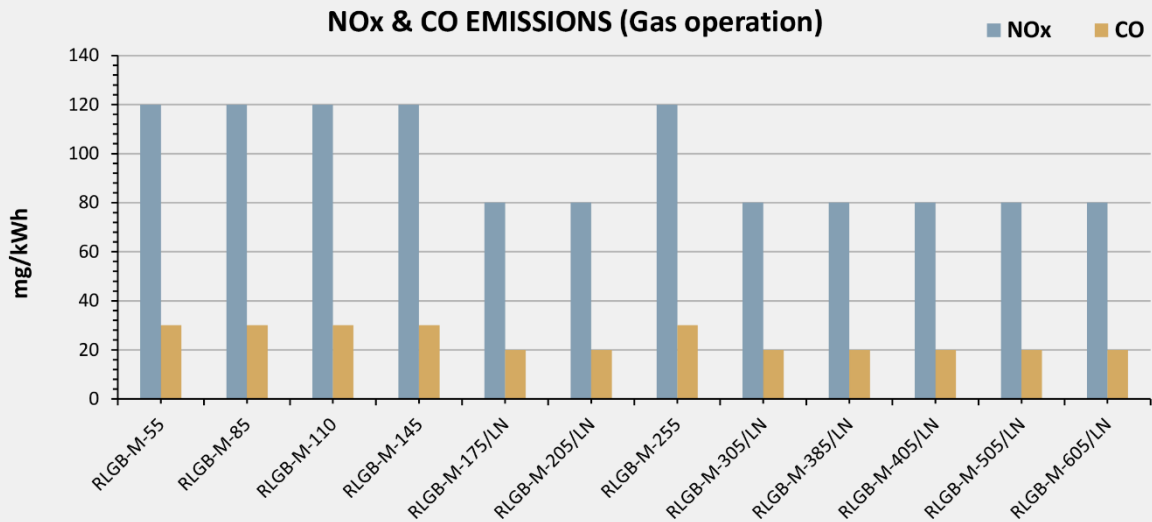
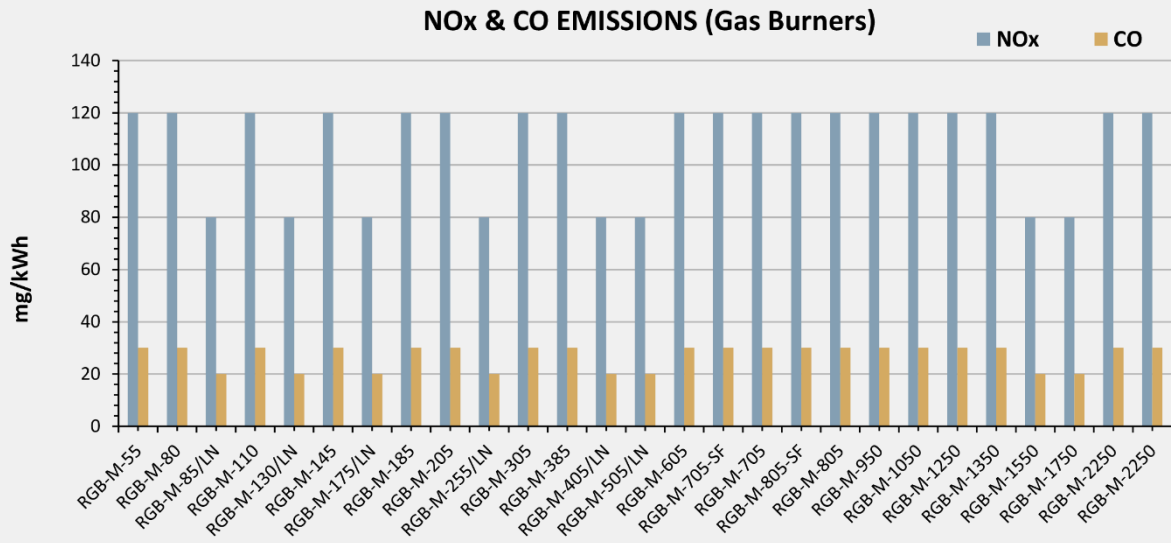



# The superiority of Low NOx combustion

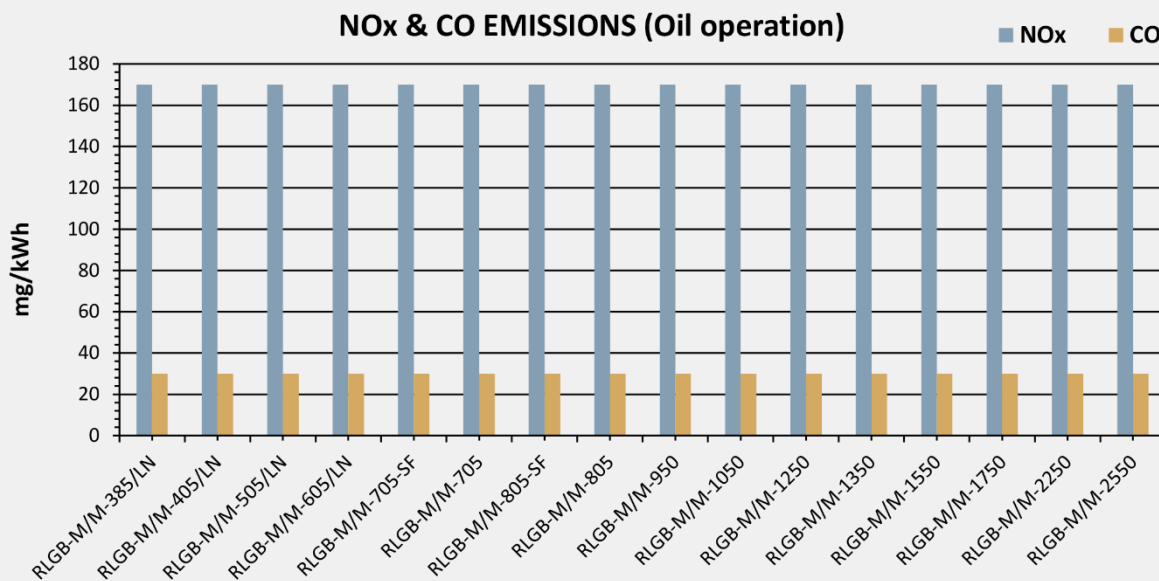
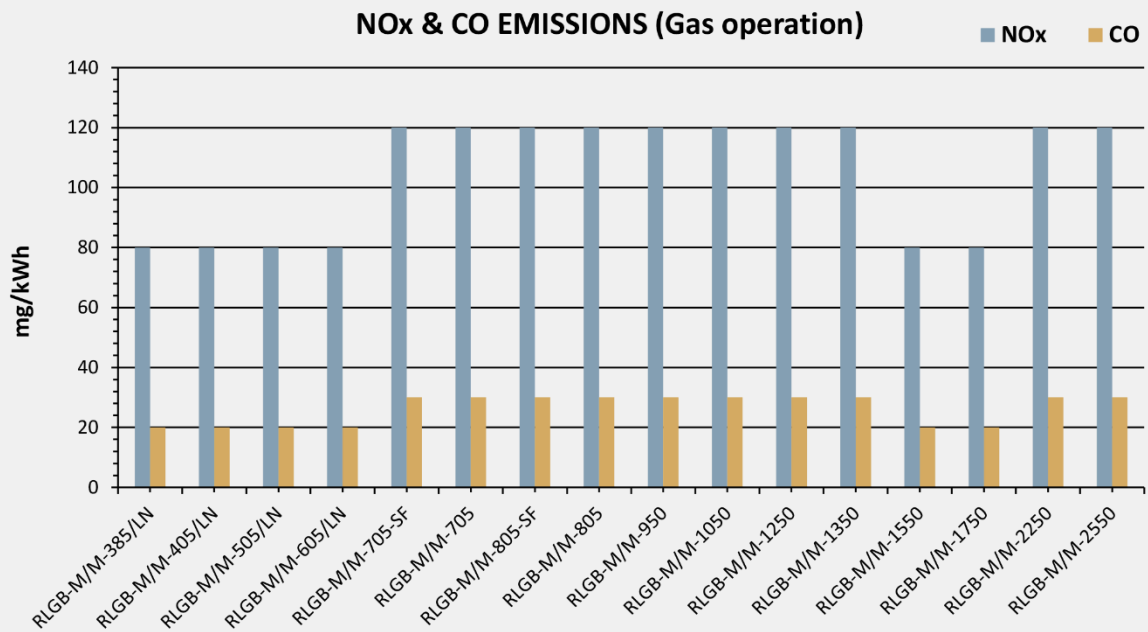

### Noise level (RGB-M Series)

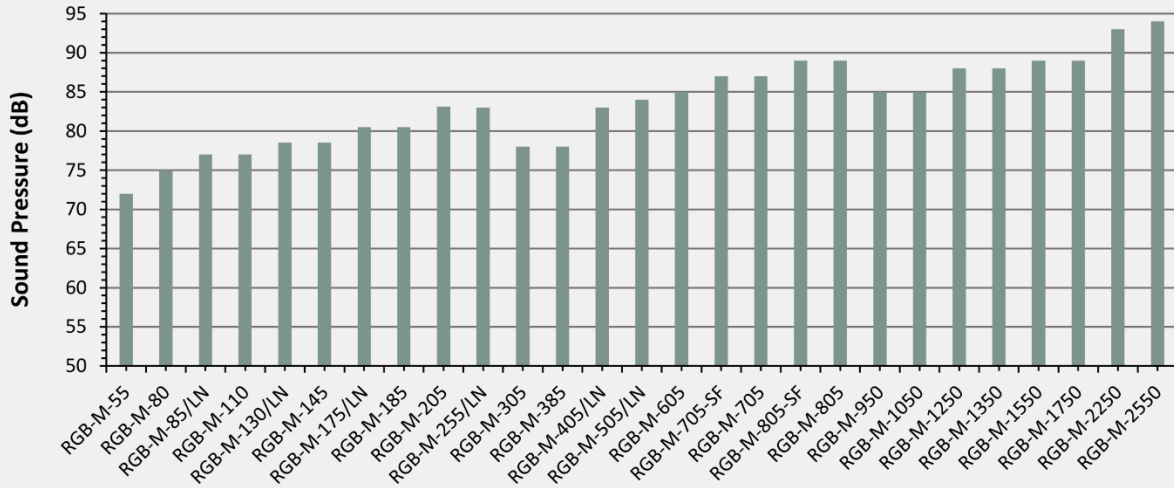

### Noise level (RLGB-M Series)

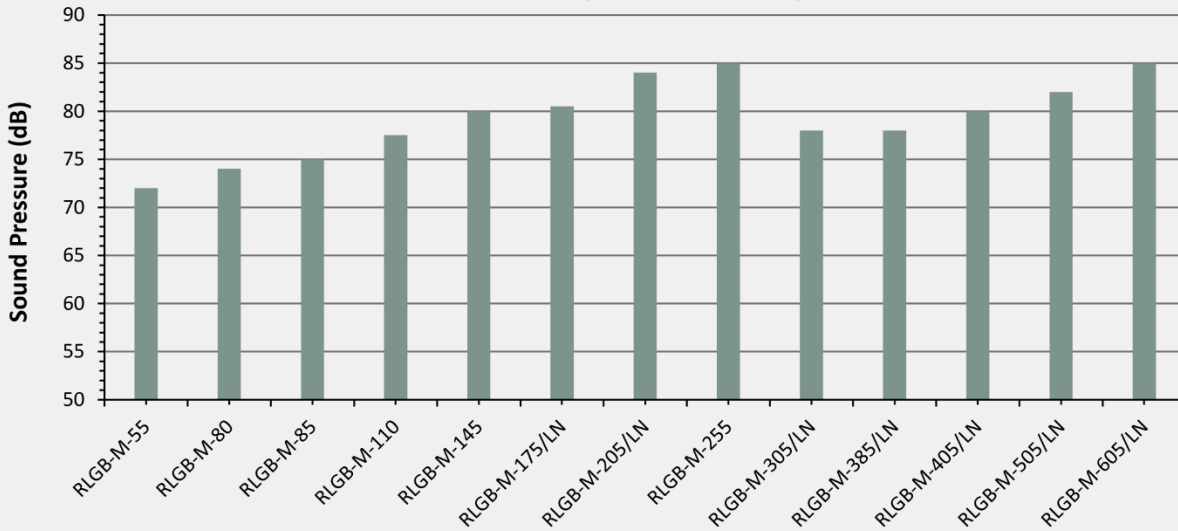

### Noise Level (RLGB-M/M Series)

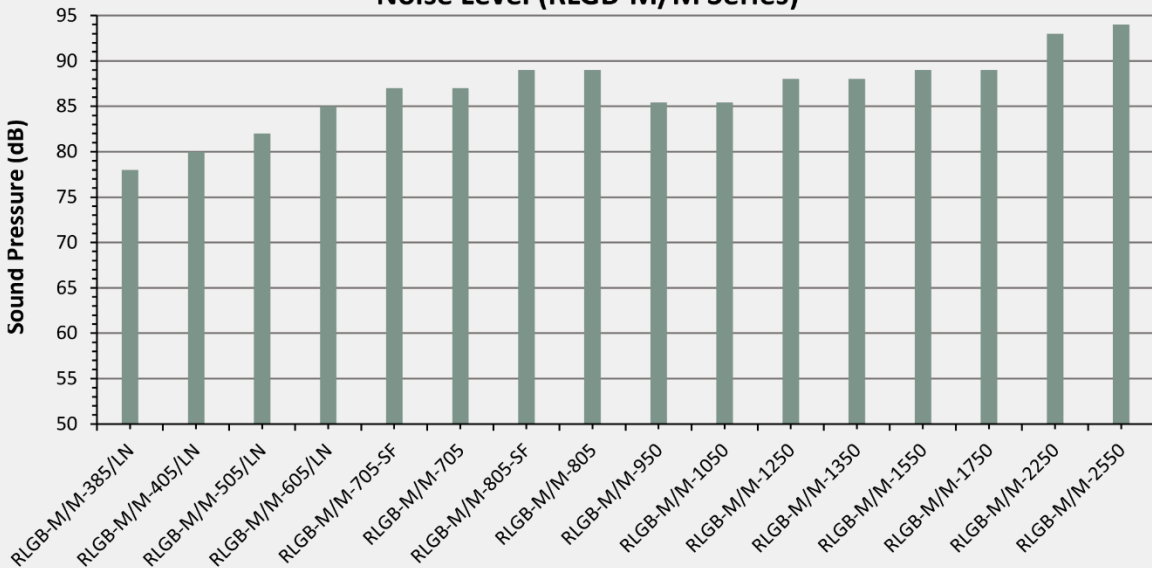

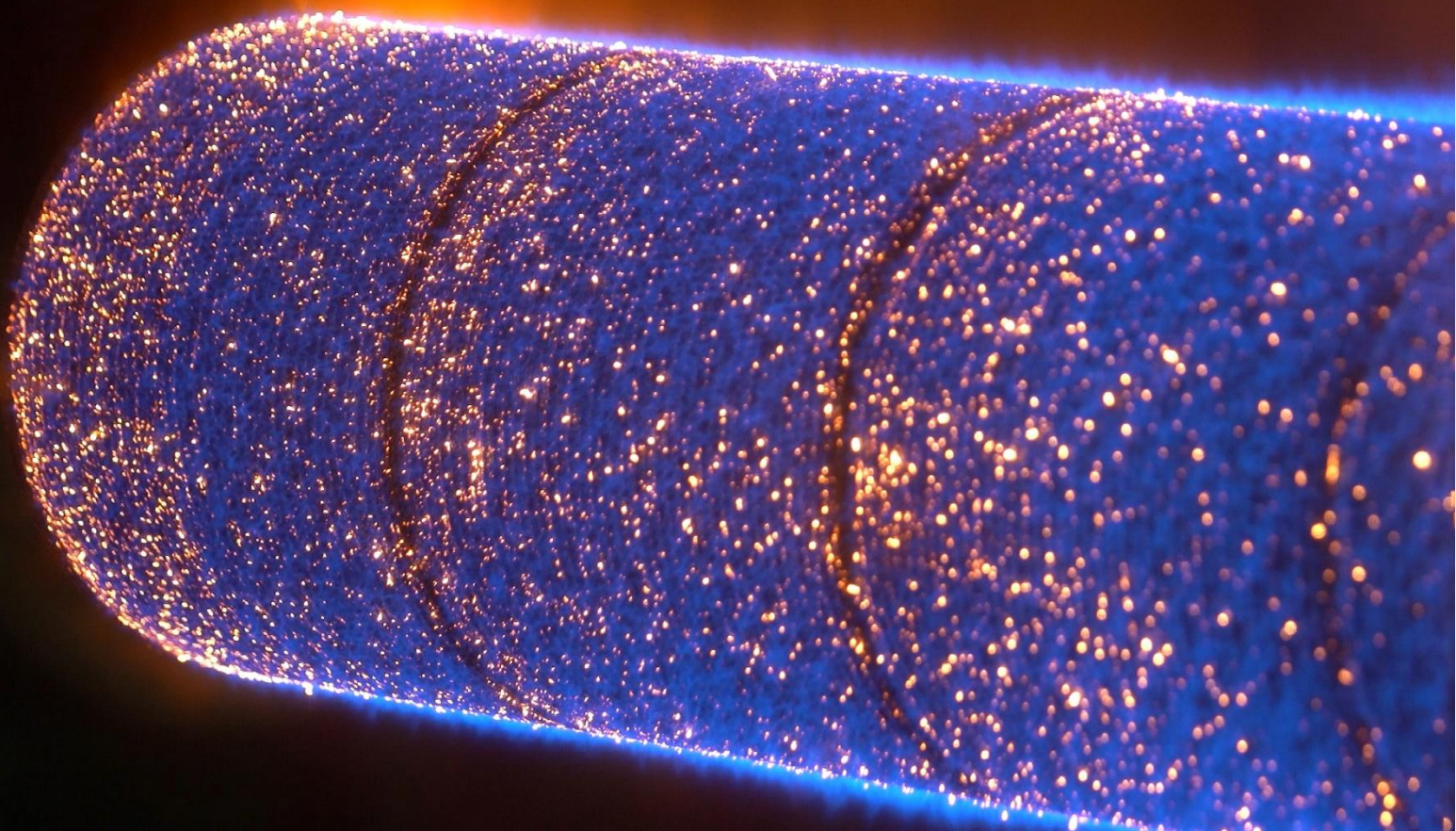



# Premixed & Post Mixed Burners

Heat Rated Output: 100-4000 kW



- SMILE INTO THE FUTURE -

[www.raadmanburner.com](http://www.raadmanburner.com)

# A new class of emissions

## PB series burners

### Ultra-Low NOx

Today, high fuel consumption and environmental pollution are serious problems, especially in industrial societies. The combustion industry plays a significant role in stated pollutants.

For more than one decade, PACKMAN Low NOx burners have been used in various heat generators and industrial plants. Currently, PACKMAN proudly introduces new generation of Ultra Low NOx pre-mixed as well as post-mixed burners known as PB-Series.

The raadman PB burner series are applied wherever the very lowest emission levels are demanded. A further advantage of this type of combustion system is that it can be utilized on appliances with particularly small combustion chambers.



## raadman premix technology for extremely low NOx emission

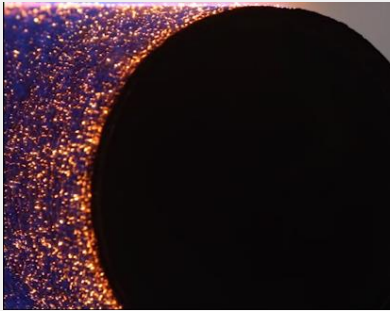

Fiber metal heating head is made of a steel chamber with a coating of metal fibers. Metal fibers are manufactured fibers composed of pure metals and metallic alloys which can be processed into textile products, porous media, plastic-coated metals, etc.

This permeable thermal coating releases most of the heat transfer through the radiation mechanism, part of which radiates from the hot surface of the thermal head and the other part from the radiation of hot combustion gases. These heating heads are produced in different ways. Weaving fibers and vacuum forming are the most common production methods.

raadman burners have always been particularly efficient and environmentally friendly.

Premix burner technology is used to achieve NOx emissions below 15 ppm and even lower.

Premixing followed by surface-stabilized combustion has been state of the art for many years in small condensing boilers. It is environmentally friendly, reliable and efficient. extending these benefits to typical heat generators with larger outputs was the developmental goal for the PB burner series. Special gas / air mix Stabilized surface combustion relies on a homogeneous gas / air mixture. For that reason, a completely new mixing assembly was developed for the PB burner series. A key feature in post mixed burner is the separated feed of gas and air, the two media are not mixed together upstream of the burner head. A uniform mixture is created by the gas flow through the distributor and the combustion air that has been set in rotation by the swirl plate.

An important feature of these thermal heads is rapid cooling process, which will occur only a few seconds after the burner is getting turned off, during the post-purge period.

The orifices of these type of burner heads are approximately 150 microns. Therefore, the combustion air must be clean of dust and particles. For this reason, a 50 microns filter is suggested to be applied at the entrance of burner air damper. If the orifices become clogged, the temperature rises dramatically and causes the head failure.

In addition, excess air plays a critical role in their life span. Even though they could last for 7-10 years in sufficient excess air condition, they would last only 20000 hours in low excess of air.



## raadman Post mixed burner

In nozzle mixed burners, fuel and air enter the combustion head from independent paths and are mixed by diffuser and flow swirling blades. The idea of designing Premixed burners has been formed to increase the Homogeneity of mixture, and consequently increases the combustion quality of the burner and reduce NOx and CO emissions.

The mixing head has been innovatively designed for complete mixing of fuel and air using staging mechanism and a set of flow rotating blades. The fuel and air are injected from independent paths and are mixed through two rows of rotating blades due to the creation of vortices and turbulence in the flow.

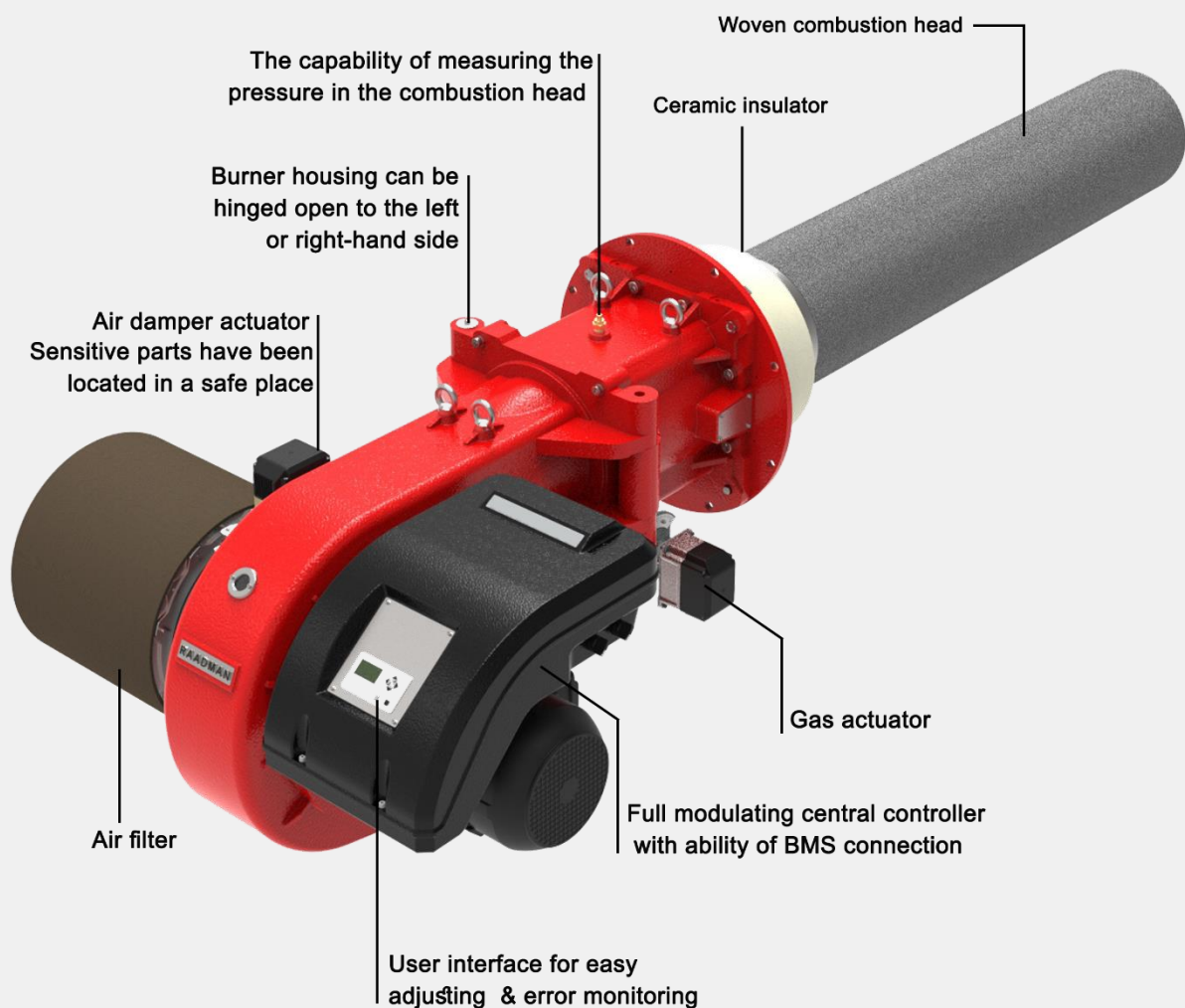

# Post mixed burner management system

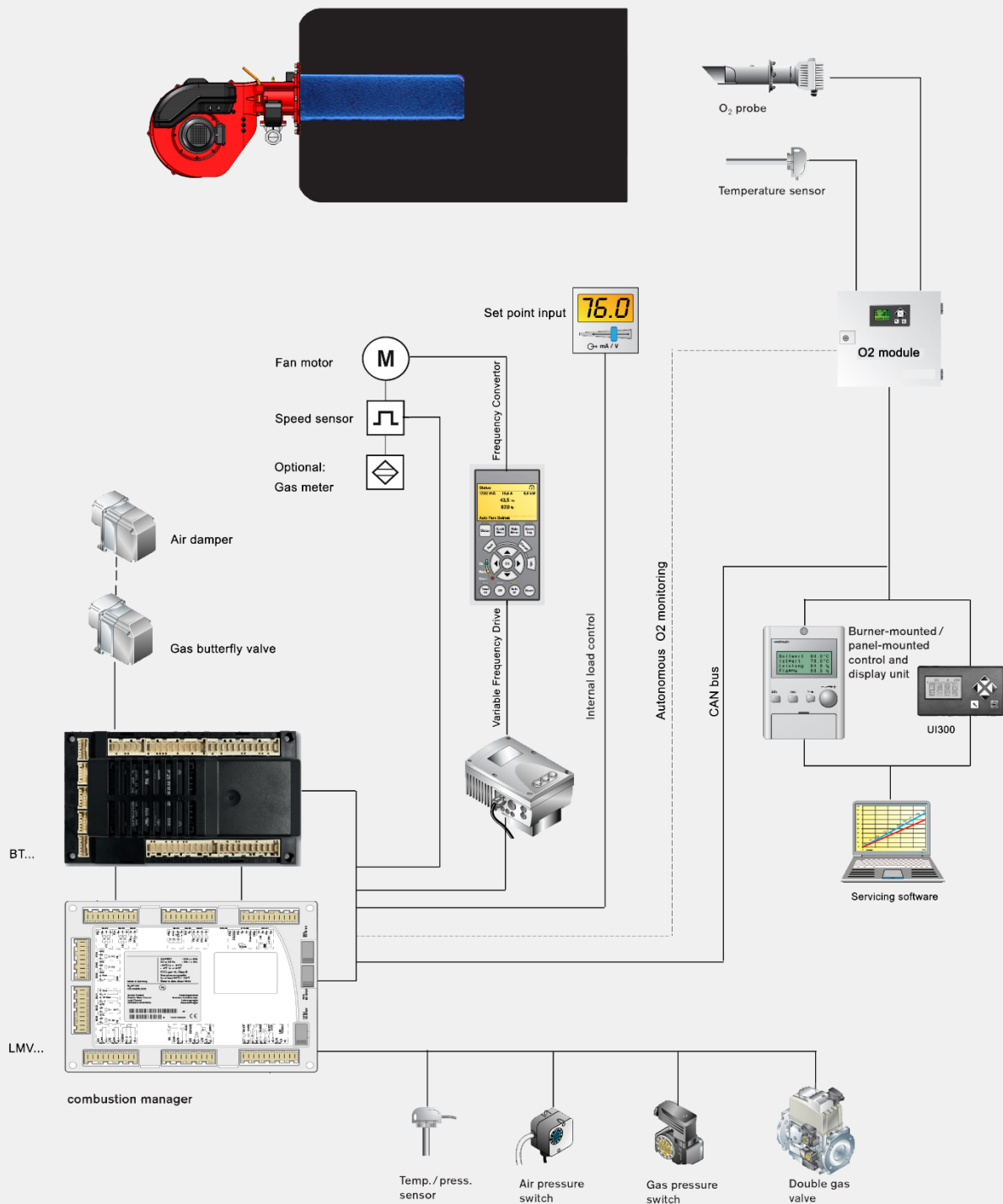





ATRISA  
500

AVTOSOLAR

AVTOSOLAR





## raadman Post Mixed burner

raadman Post Mixed burner cover a firing range of 125 to 4000 kW, and they are designed for a wide range of domestic and industrial applications. The Post Mixed burner model and capacity are indicated in the table.

Burner	Capacity (kW)	Turn down*
RPB-M-125/PM	NG:300-1200	1:4
RPB-M-150/PM	NG:380-1500	1:4
RPB-M-175/PM	NG:430-1700	1:4
RPB-M-200/PM	NG:500-2000	1:4
RPB-M-265/PM	NG:650-2600	1:4
RPB-M-300/PM	NG:750-3000	1:4
RPB-M-400/PM	NG:1000-4000	1:4

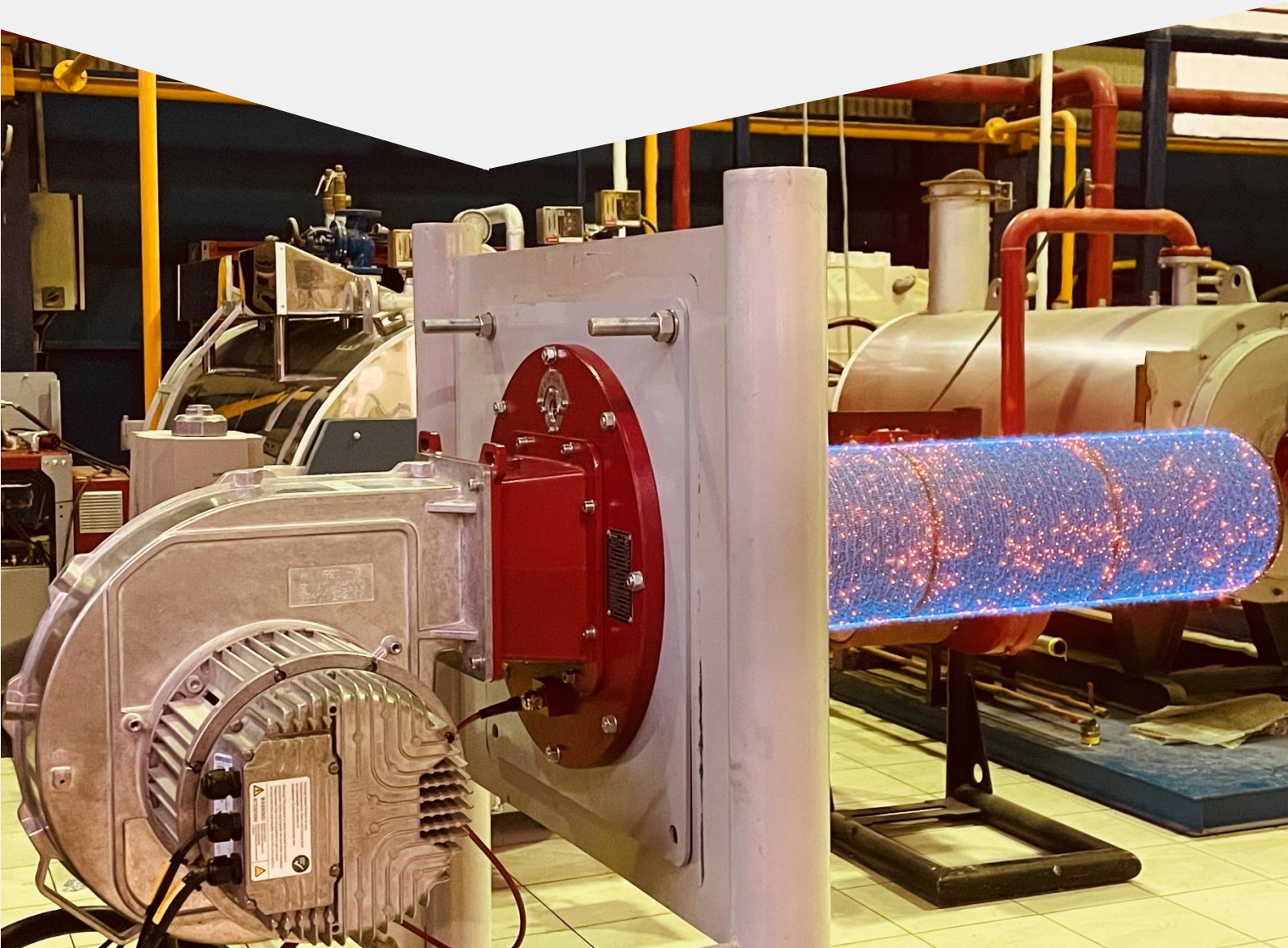

## General dimension: Post mixed burner

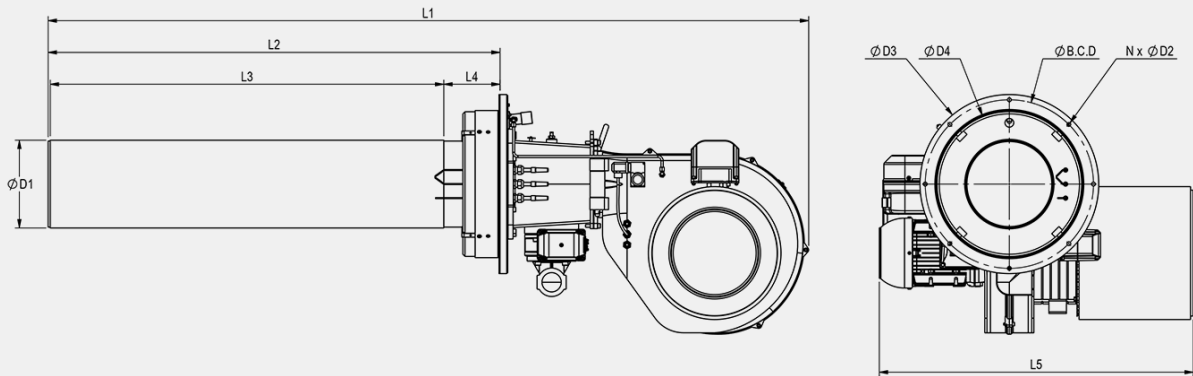

Burner Type	L1	L2	L3	L4	D1	D2	D3	D4	N	B.C.D
RPB-M-50/PM	1161	461	300	161	200	11	460	364	8	435
RPB-M-80/PM	1328	608	450	158	245	11	510	419	8	480
RPB-M-125/PM	1720	841	674	161	245	11	510	419	8	480
RPB-M-150/PM	1891	1010	843	161	245	11	510	419	8	480
RPB-M-175/PM	2031	1150	983	161	245	11	510	419	8	480
RPB-M-200/PM	2171	1290	1123	161	245	11	510	419	8	480
RPB-M-265/PM	2585	1364	1145	213	300	11	580	475	8	550
RPB-M-300/PM	2813	1591	1374	211	300	11	580	477	8	550
RPB-M-400/PM	2985	1746	1455	286	350	13.5	655	570	8	620

The real sense of mixing

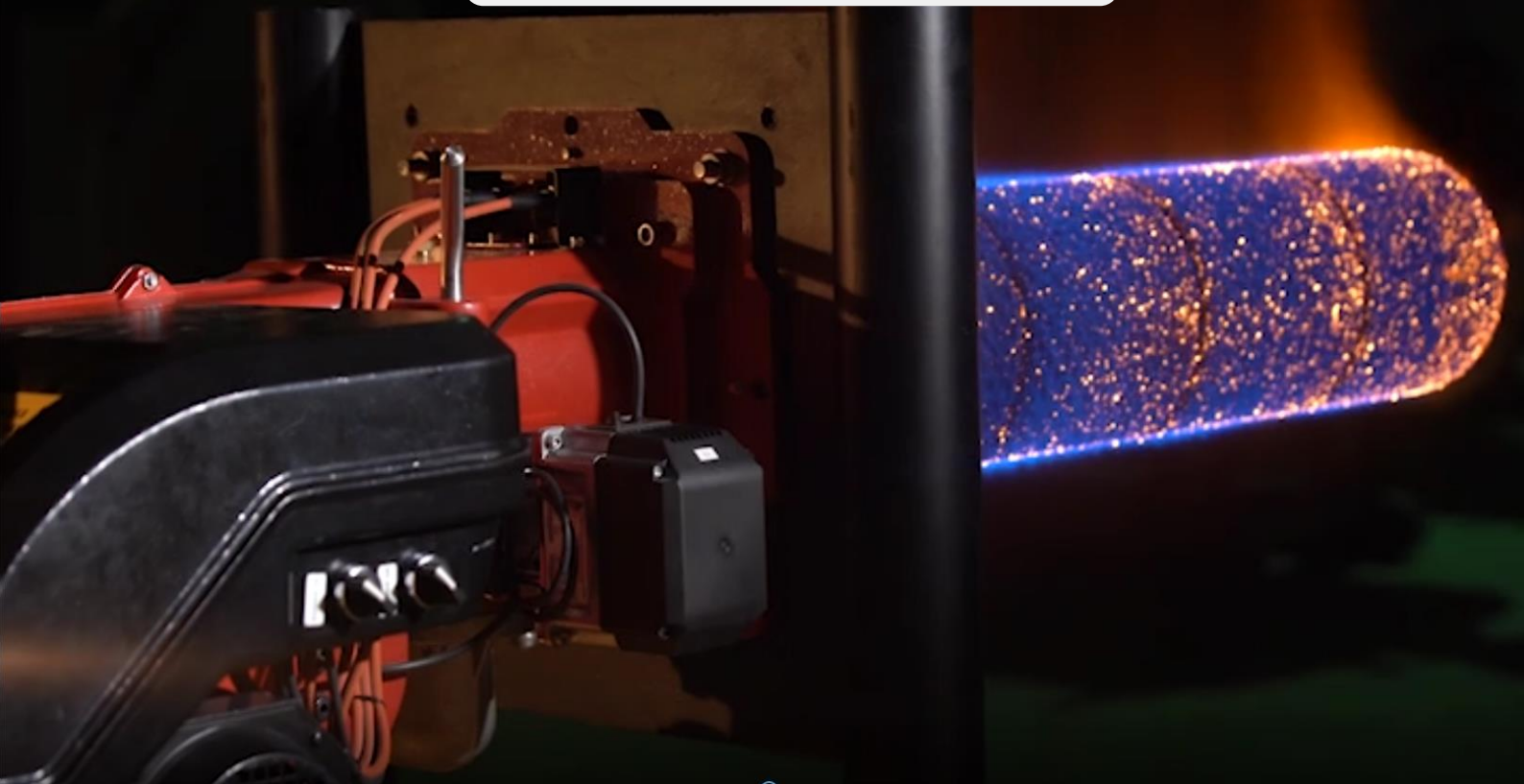





## Installation and removal of Post mixed burners

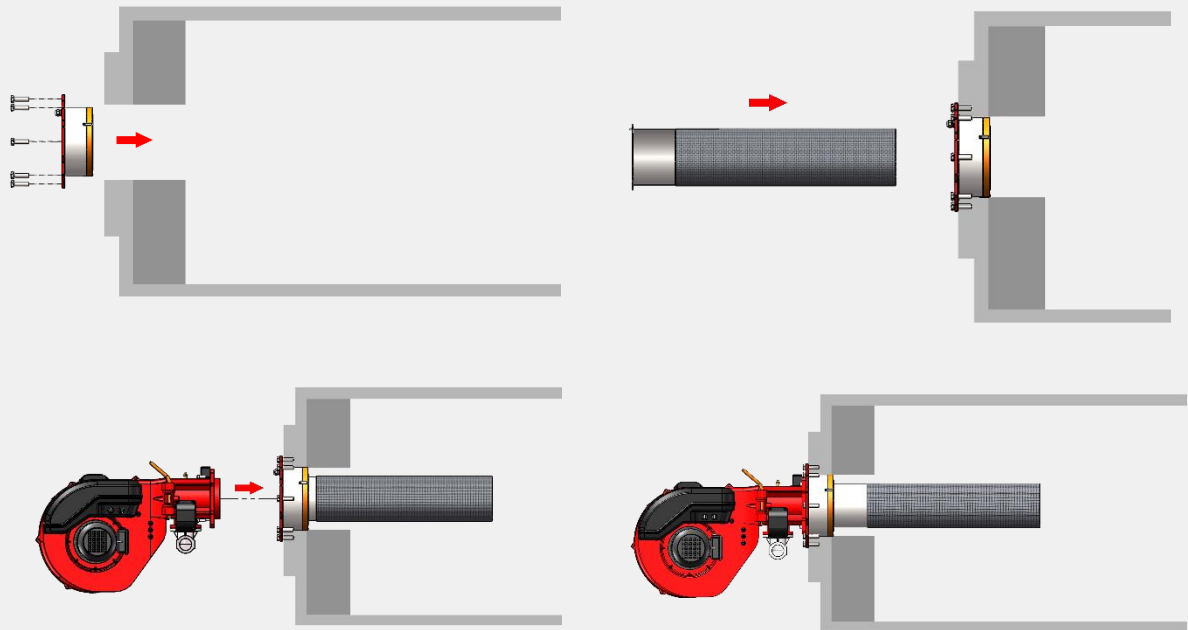

**PACKMAN Low NOx Post-Mixed burner**  
Capacity: 750 - 3000 kW





raadman Premixed & Post mixed Burner productions





## raadman Premixed burner

raadman Premixed burners are equipped with a centrifugal fan and a brushless electromotor that guarantee high performance, low sound emission and optimized speed variation. The motor speed variation controls the regulation of gas delivery. Pre-mixed burner gas train consists of a pneumatic proportioning multiblock gas valve that regulates gas input by fan pressure feedback.

Thanks to standard mixing venturis, Gas and combustion air are completely mixed before the fan wheel. Using the PWM pulse and, as a consequence, controlling the rotation of blower, the mixture is transferred to combustion area. Finally, a well spark leads to pre-mixed flame with minimum pollution.

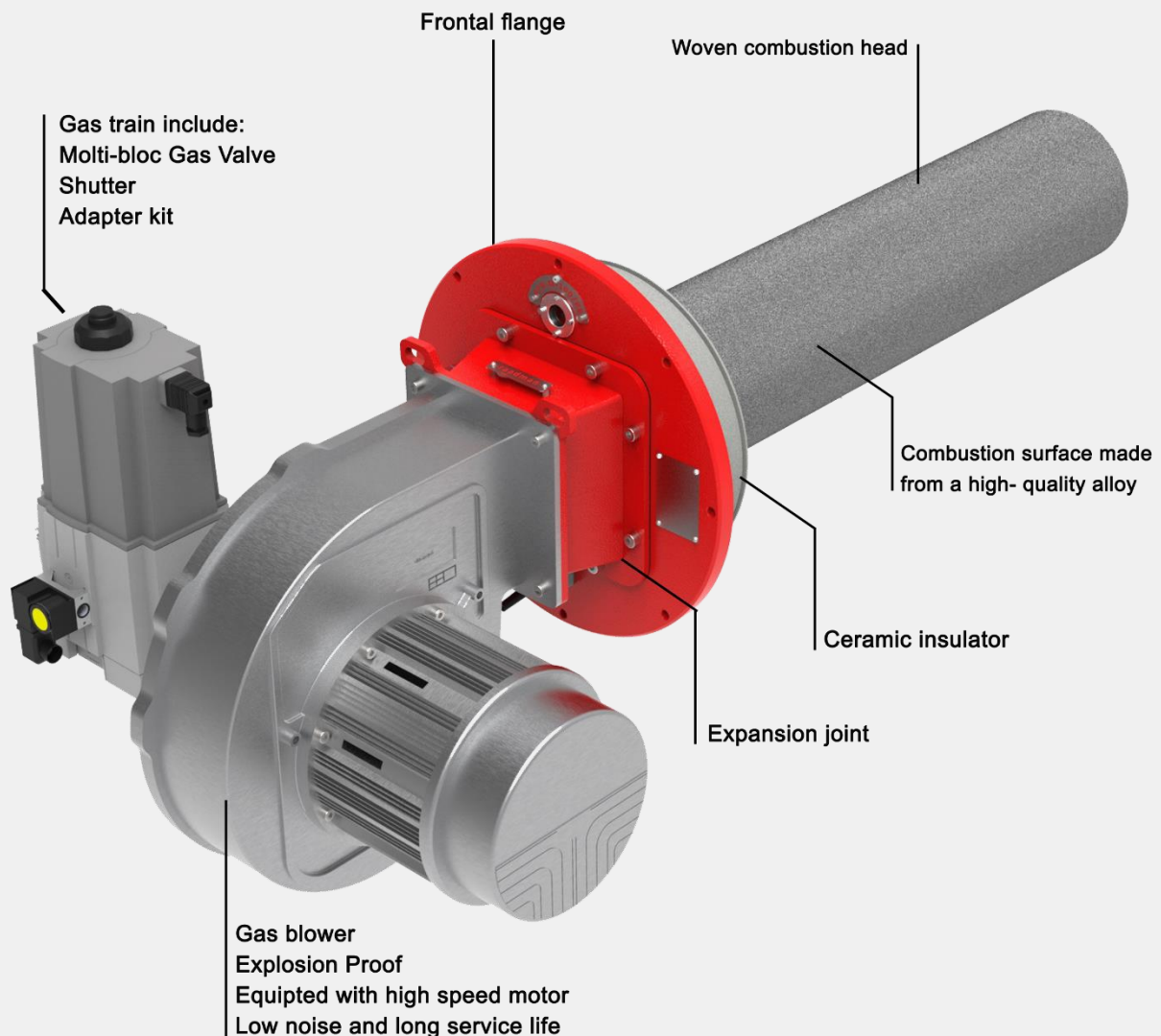

# Premixed burner management system

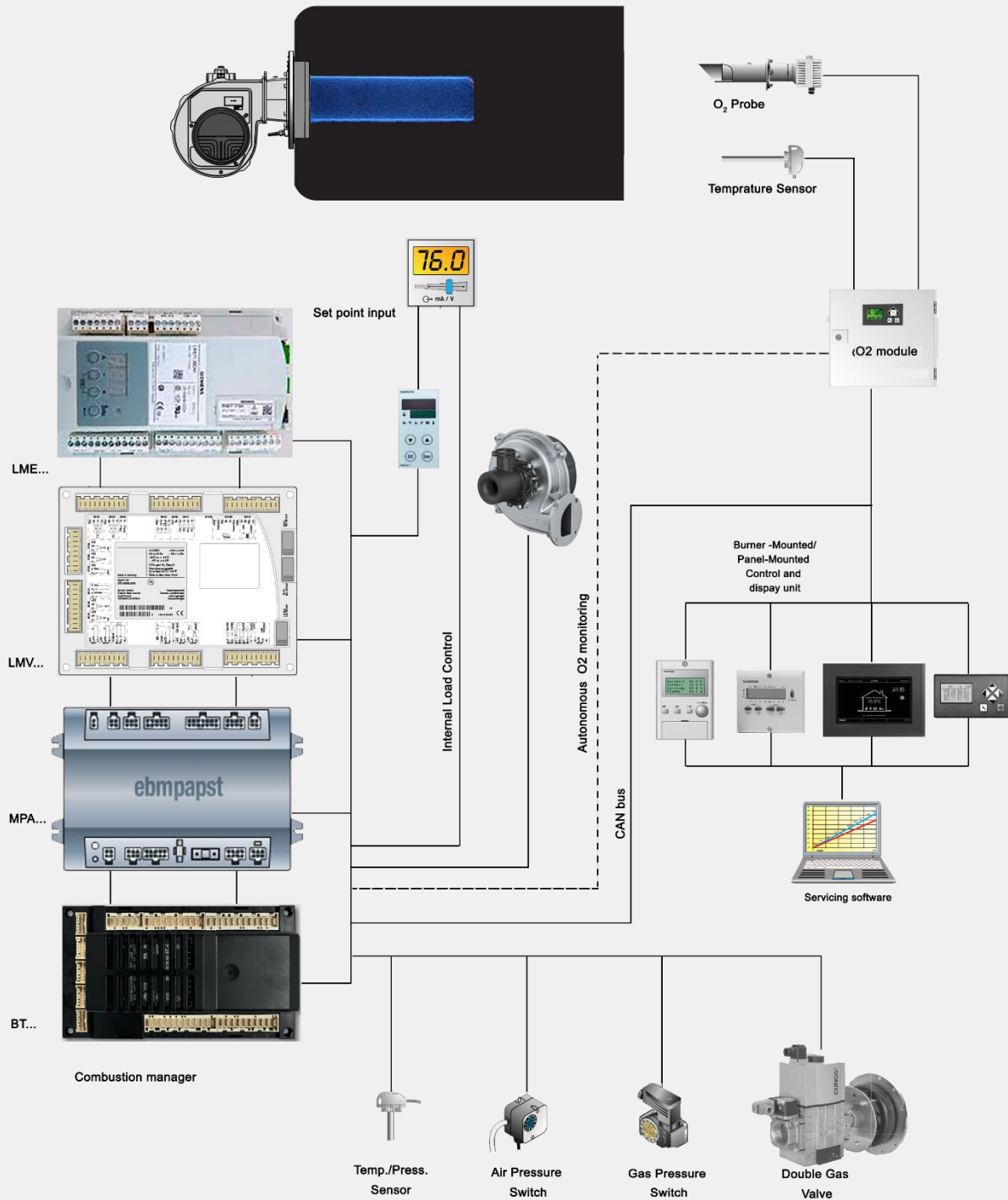





## raadman Premixed burner range

raadman Premixed burner cover a firing range of 37 to 4000 kW, and they are designed for a wide range of domestic and industrial applications. The Premixed burner model and capacity are indicated in the table.

Burner	Capacity (kW)	Turn down*
RPB-M-15/PE	NG:37-150	1:4
RPB-M-20/PE	NG:50-200	1:4
RPB-M-50/PE	NG:125-500	1:4
RPB-M-80/PE	NG:200-800	1:4
RPB-M-125/PE	NG:300-1200	1:4
RPB-M-150/PE	NG:380-1500	1:4
RPB-M-175/PE	NG:430-1700	1:4
RPB-M-200/PE	NG:500-2000	1:4
RPB-M-300/PE	NG:750-3000	1:4
RPB-M-400/PE	NG:1000-4000	1:4



## General dimension: Premixed burner

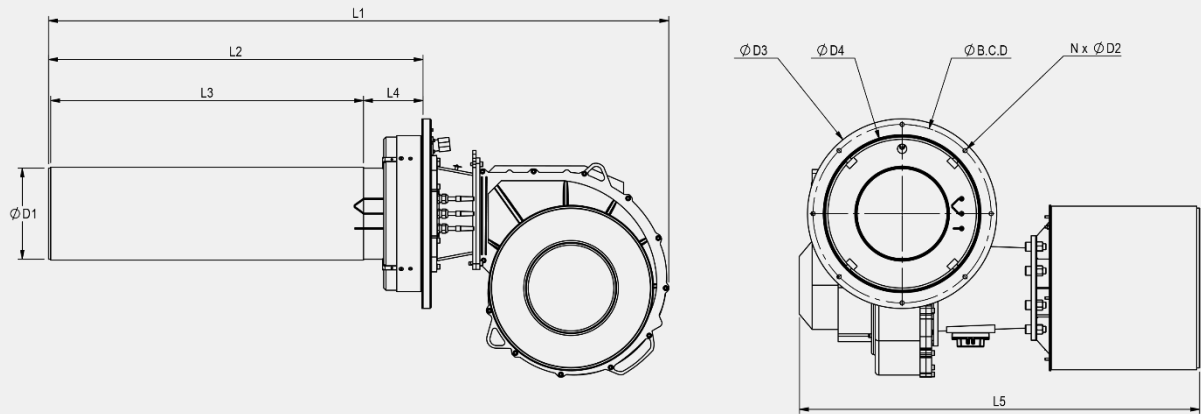

Burner Type	L1	L2	L3	L4	D1	D2	D3	D4	N	B.C.D
RPB-M-15/PE	745	442	204	238	98	6.6	285	228	8	265
RPB-M-20/PE	838	515	272	238	98	6.6	285	228	8	265
RPB-M-50/PE	920	461	300	161	200	11	460	364	8	435
RPB-M-80/PE	1192	617	450	161	245	11	510	419	8	480
RPB-M-125/PE	1424	841	674	161	245	11	510	419	8	480
RPB-M-150/PE	1668	1010	843	161	245	11	510	419	8	480
RPB-M-175/PE	1806	1150	983	161	245	11	510	419	8	480
RPB-M-200/PE	1948	1290	1123	161	245	11	510	419	8	480
RPB-M-300/PE	2630	1591	1374	211	300	11	580	475	8	550
RPB-M-400/PE	2782	1746	1455	286	350	13.5	670	574	8	620

# Installation and removal of Premixed burners

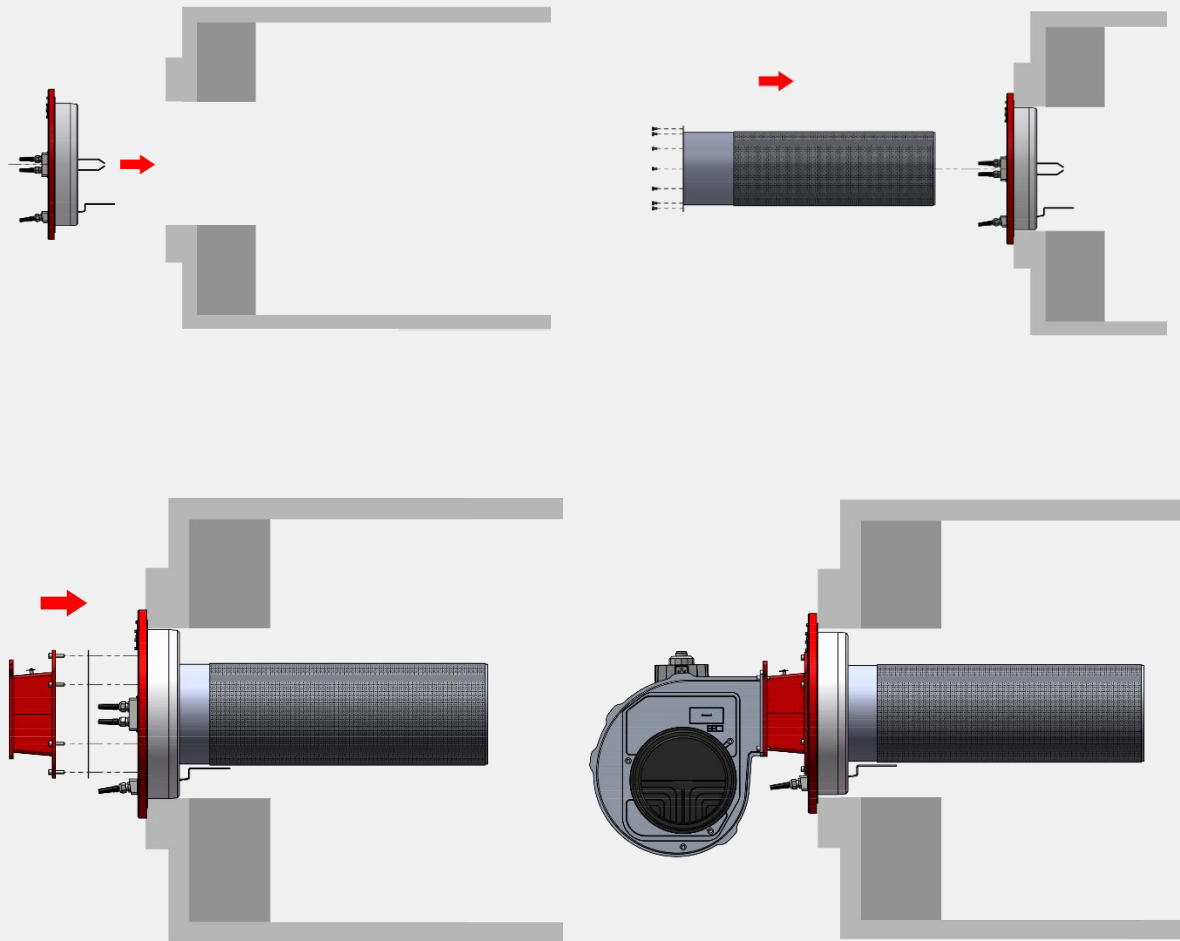



# Gas train selection (Post mixed)

## GT1

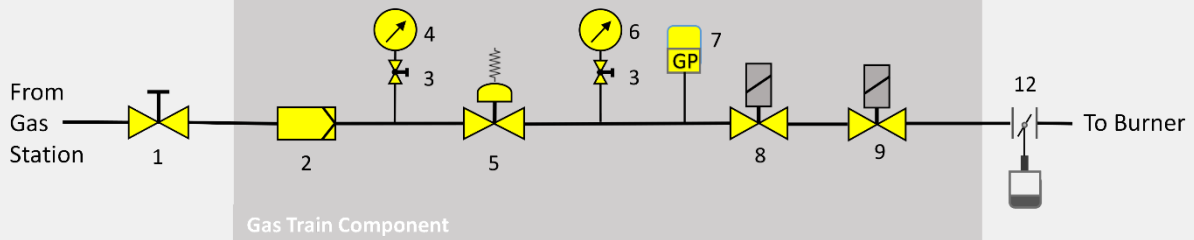

## GT2

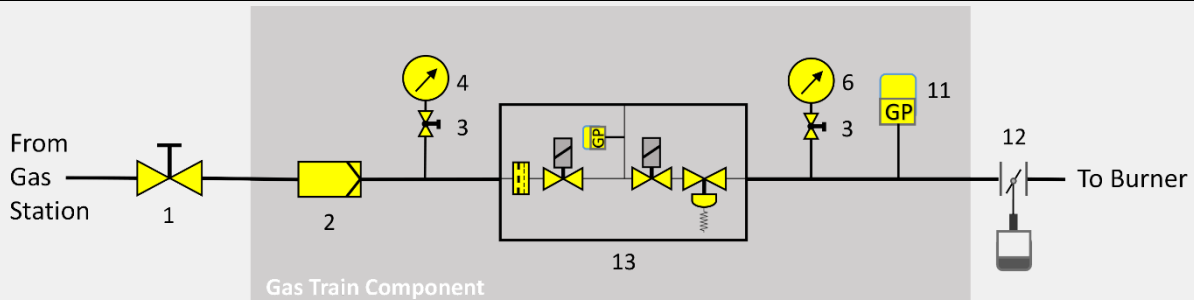

- |                                      |                                   |
|--------------------------------------|-----------------------------------|
| 1: Ball valve                        | 8: Safety gas valve               |
| 2: Gas filter                        | 9: Main gas valve                 |
| 3: Push button valve                 | 10: Leak Test gas pressure switch |
| 4: Pressure Gauge                    | 11: Max. gas pressure switch      |
| 5: Pressure regulator (Low-pressure) | 12: Butterfly valve               |
| 6: Pressure Gauge                    | 13: Multi-Block Solenoid Valve    |
| 7: Min. gas pressure switch          |                                   |

RPB-M series		
Burner	Gas model	Gas Train Size
RPB-M-50/PM	GT-1	Rp 1 ½
	GT-2	Rp 1 ½
RPB-M-80/PM	GT-1	Rp 1 ½
	GT-2	Rp 1 ½
RPB-M-125/PM	GT-1	Rp 2
	GT-2	Rp 2
RPB-M-150/PM	GT-1	Rp 2
	GT-2	Rp 2
RPB-M-175/PM	GT-1	Rp 2
	GT-2	Rp 2
RPB-M-200/PM	GT-1	Rp 2
	GT-2	Rp 2
RPB-M-265/PM	GT-1	DN65
	GT-2	Rp 2
RPB-M-300/PM	GT-1	DN65
	GT-2	Rp 2
RPB-M-400/PM	GT-1	DN80
	GT-2	DN80

# Pre-mixed gas burner

For mixing fuel and air in premix burners, a venturi is used before fan. The gas line used in these burners is a multiblock gas line. This block consists of two solenoid valves, a regulator and a microfilter.

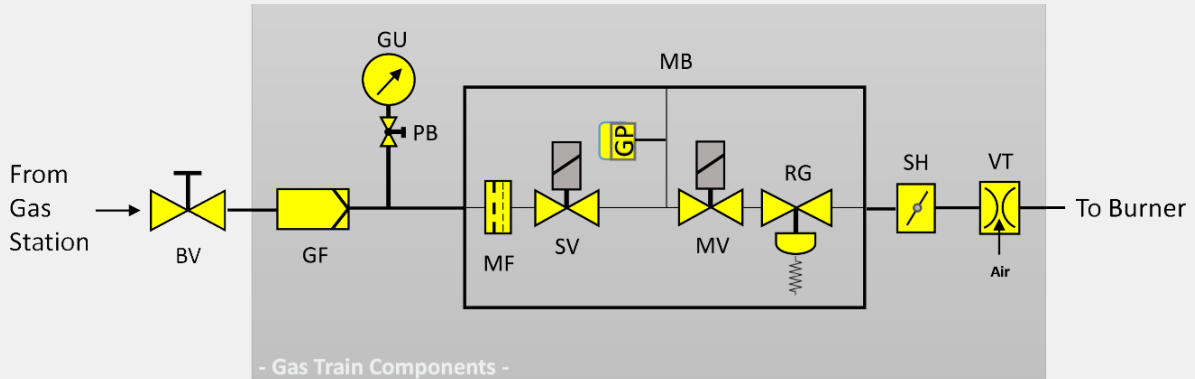
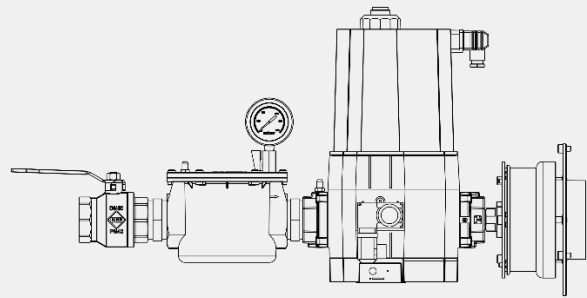

## Swirlplate - The heart of the WhirlWind system



### Integrated Venturi 2. Signal amplifier

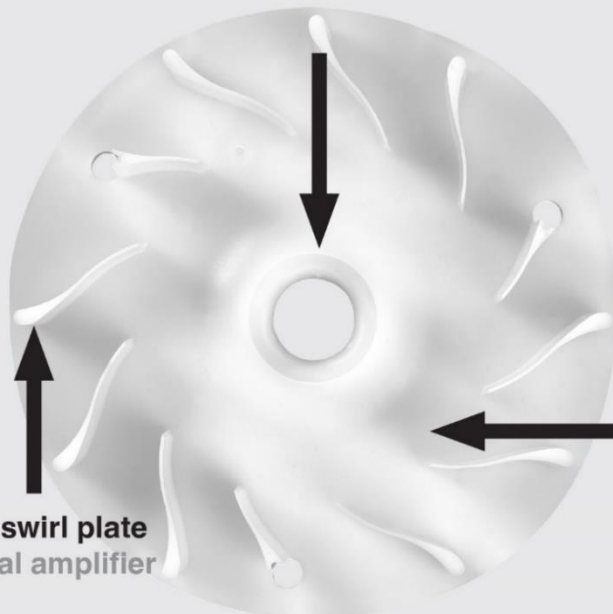

- Swirlplate**
- + Patented
  - + Two stage cascaded signal amplification
  - + Breaks up uniform flow pattern and reduces resonances

**Spiral swirl plate**  
1. Signal amplifier

**Silencer pocket**

**- raadman -**

**Dual Block Burner**

---

● **Air Block**

---

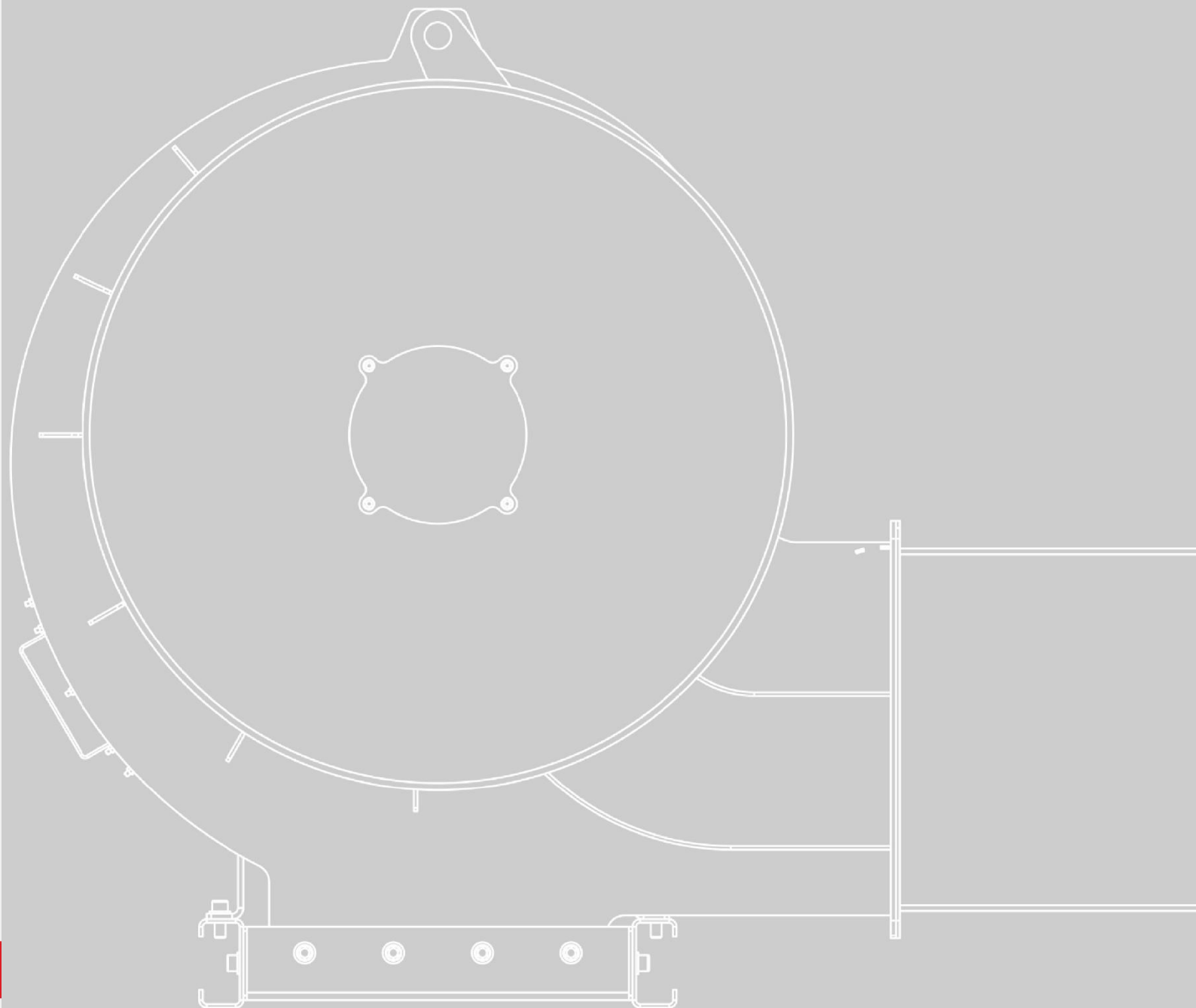



Combustion Block

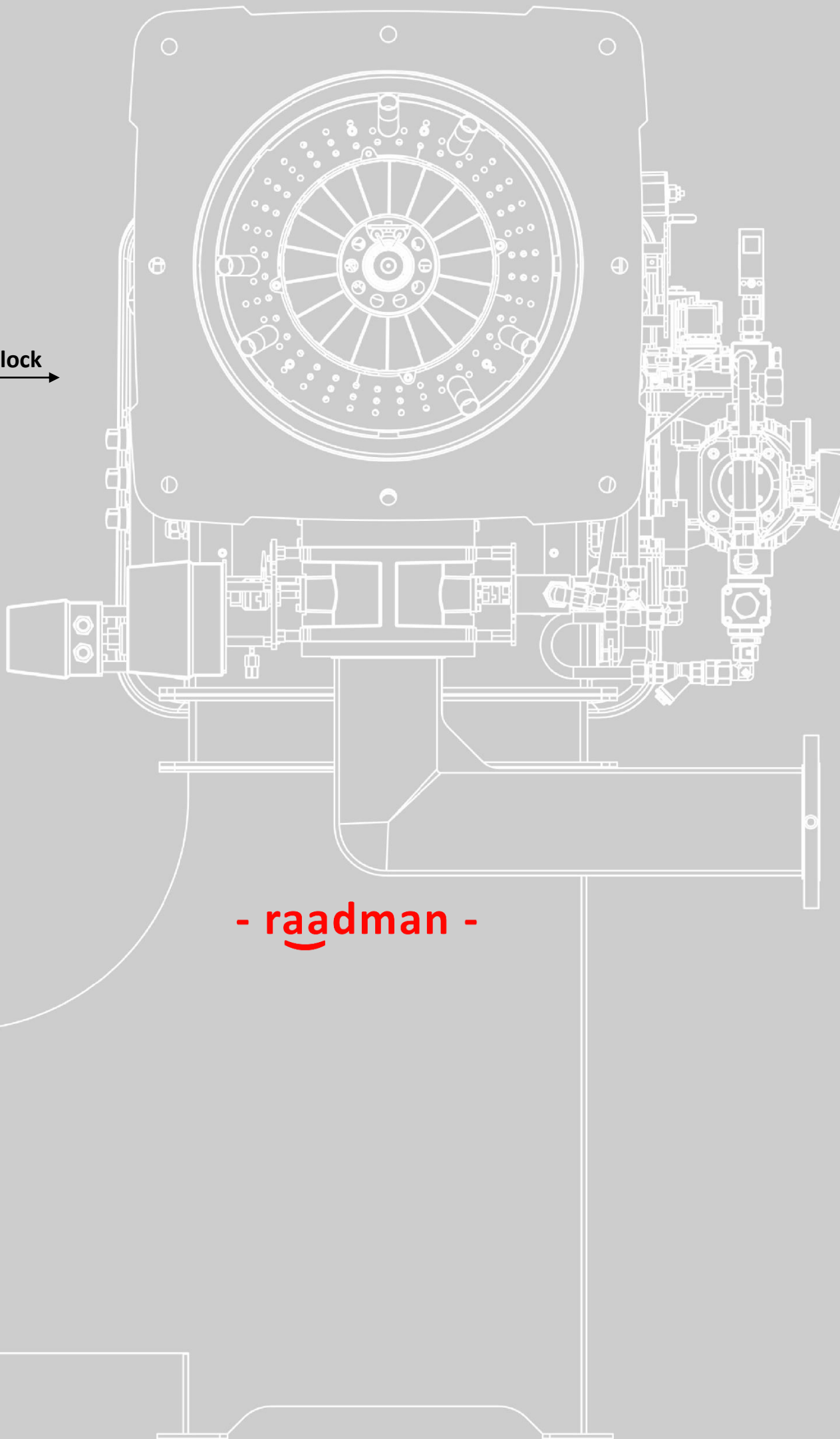

- raadman -

Superiority of combustion by distinctive design and manufacturing processes.

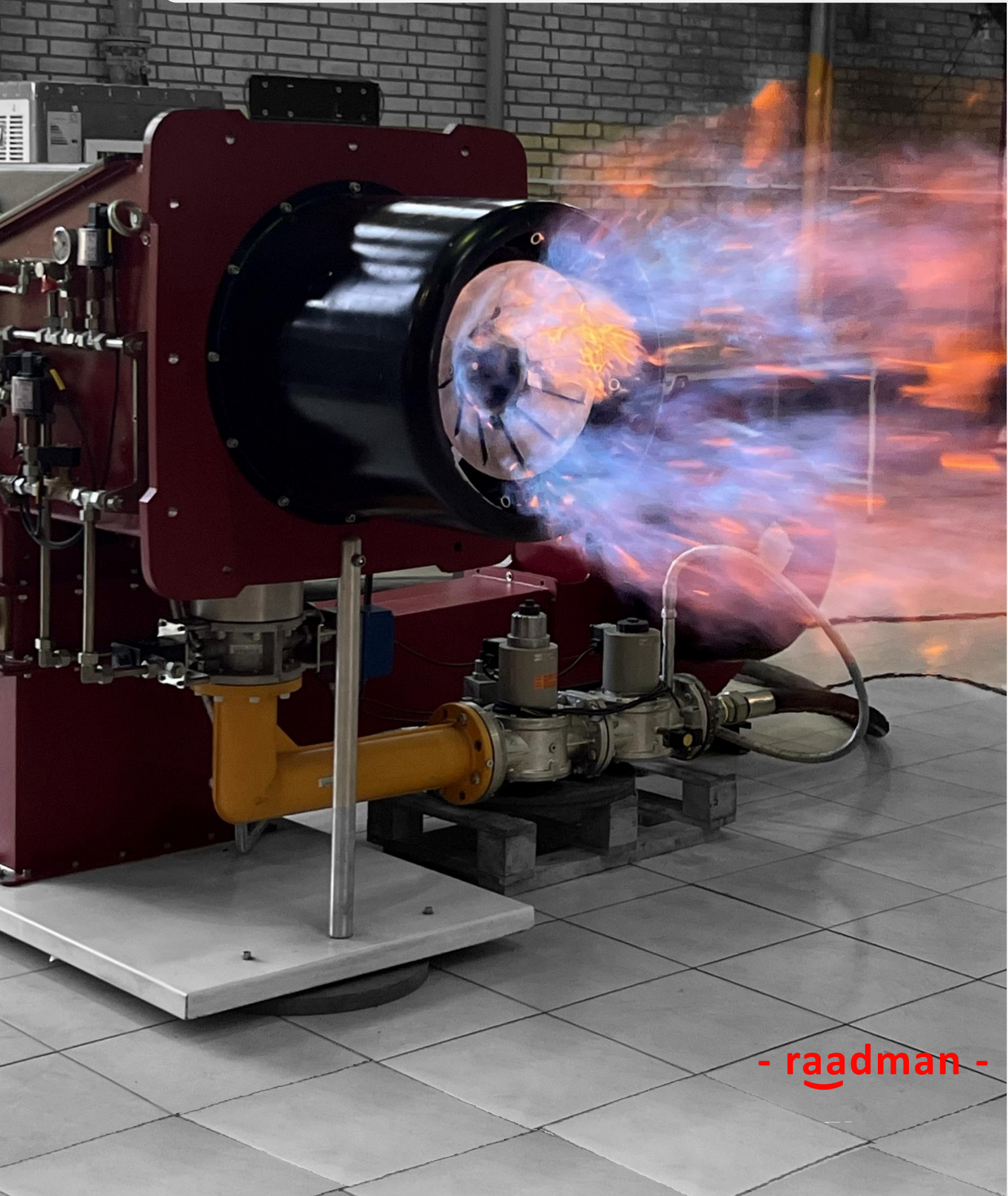

- raadman -

# Dual Block Burners

Heat Rated Output: 1000-32000 kW



- SMILE INTO THE FUTURE -

[www.raadmanburner.com](http://www.raadmanburner.com)



# Burner management system overview

The full electronic modulating burners are designed to operate safely throughout its firing range from high fire to low fire. The most common turndown rating in DB-Series burner is 1:8 up to 1:10. DB-Series burners are equipped with an electronic microprocessor management panel which controls the air damper servomotor, fuel servomotors as well as head regulating sleeve. Using electronic modulation, hysteresis is prevented by the precise control of the separated and independent servomotors and the software linked by can - bus. The LAMTEC ETAMATIC/CMS combustion managers or AUTOFLAME MINI MK8 or Siemens LMV51/52, as the most popular brands, are frequently used in raadman DB-Series Modular burners.

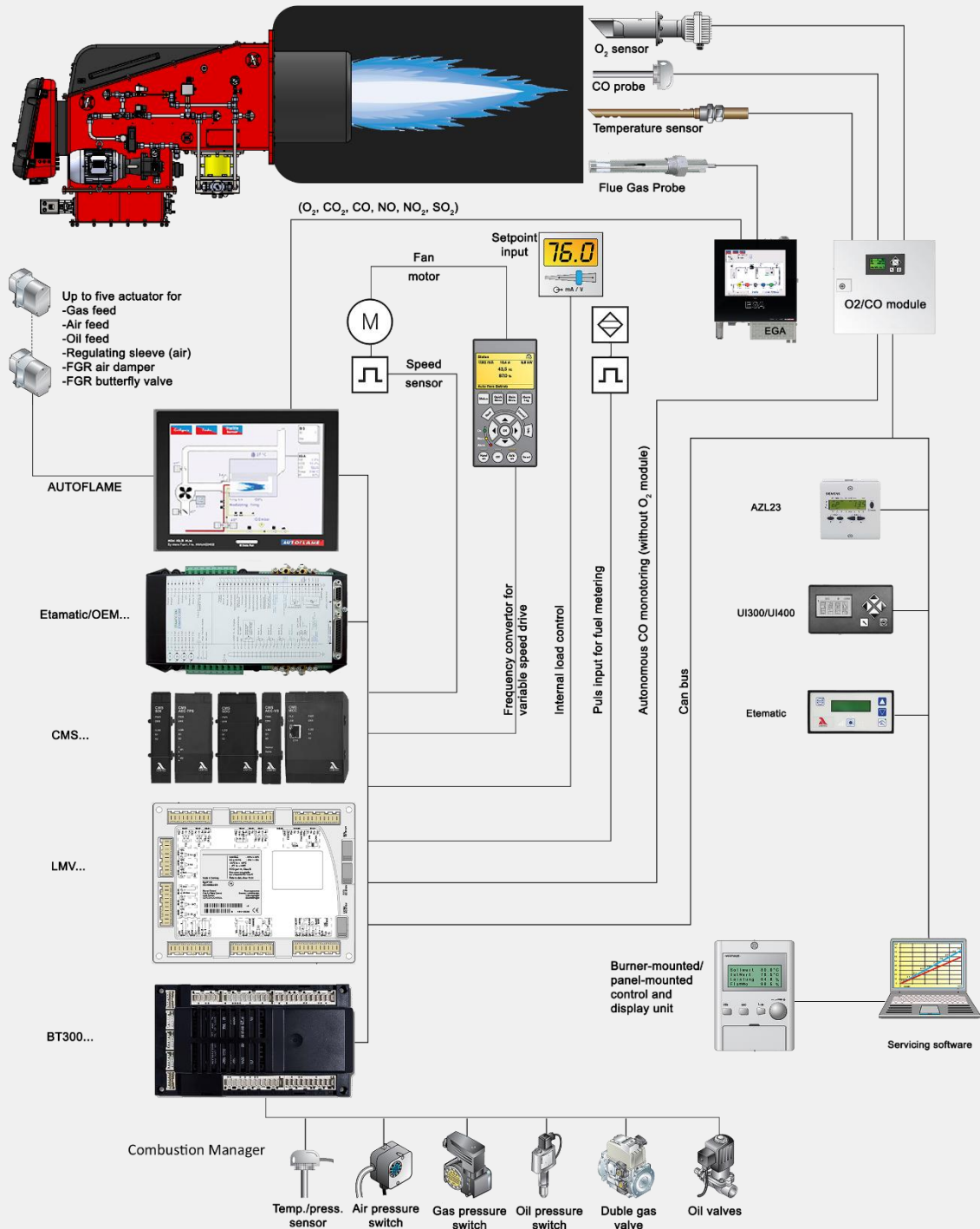

# Reliable flame monitoring

When it comes to reliability and safety, flame monitoring plays a crucial role.

For determining the best method of flame monitoring, not only the burner and its fuel, but also the system functioning and the conditions inside the combustion chamber should be taken into account. Heat generators with one flame per combustion chamber are easier to monitor than those with multiple flames. In the latter case, it also depends whether the flames are firing into the combustion chamber from the same or opposite directions.

Biomass plant and waste incinerators need a flame monitoring system that is not affected by extraneous flames.

DB series are for plant with multiple burners firing from different directions into a single combustion chamber, and for process plant with various flame sources. The flame scanners monitor each flame separately via up to ten load-dependent switching thresholds for each fuel.

## flame scanner

The compact flame scanner is composed of a cylindrical casing comprising an axial light incidence aperture, a processing status indicator at the rear of the unit and operational controls which can be accessed by removing the cover.

The device is connected through an integrated standard plug and using a connection cable required for this with coupler.

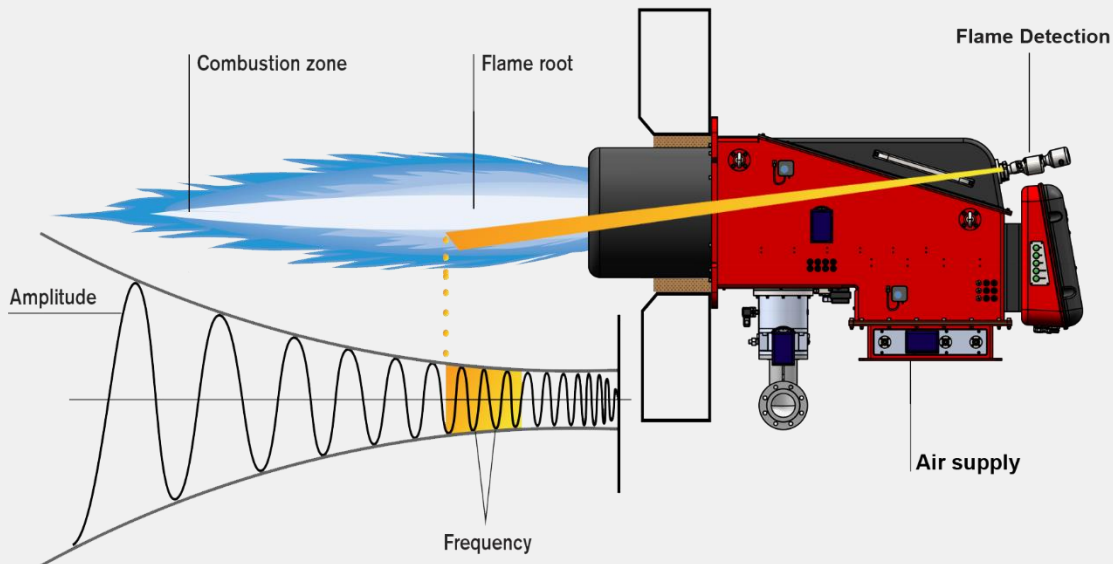
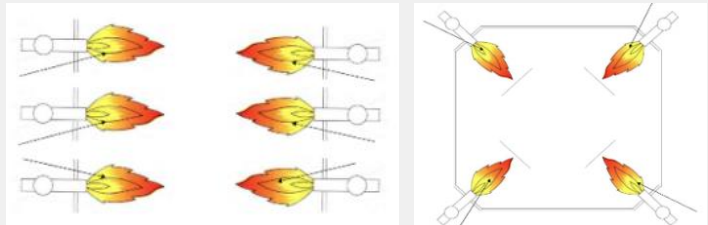

## raadman RGB-M-X-DB series Burner

raadman dual block gas burners cover a firing range of 7000 to 32000 kW, and they are designed for a wide range of domestic and industrial applications. The dual block gas burners model and capacity are indicated in the table.

\*Special note: Turn-down ratio higher than (1:8, 1:9, 1:10, etc.) are accessible for the burner with the head actuator. Otherwise, without a head actuator, the maximum turn-down ratio is 1:6.

Burner	Capacity (kW)	Turn down*
RGB-M-705-DB-SF	NG:1000-7000	1:7
RGB-M-705-DB	NG:1000-7000	1:7
RGB-M-805-DB-SF	NG:1000-8000	1:8
RGB-M-805-DB	NG:1000-8000	1:8
RGB-M-950-DB	NG:1000-9000	1:9
RGB-M-1050-DB	NG:1000-10500	1:10
RGB-M-1250-DB	NG:1200-12000	1:10
RGB-M-1350-DB	NG:1350-13500	1:10
RGB-M-1550-DB	NG:1900-15000	1:8
RGB-M-1750-DB	NG:2200-17000	1:8
RGB-M-2250-DB	NG:2750-22000	1:8
RGB-M-2550-DB	NG:3150-25000	1:8
RGB-M-3250-DB	NG:4000-32000	1:8





## General dimension: RGB-M-X-DB series

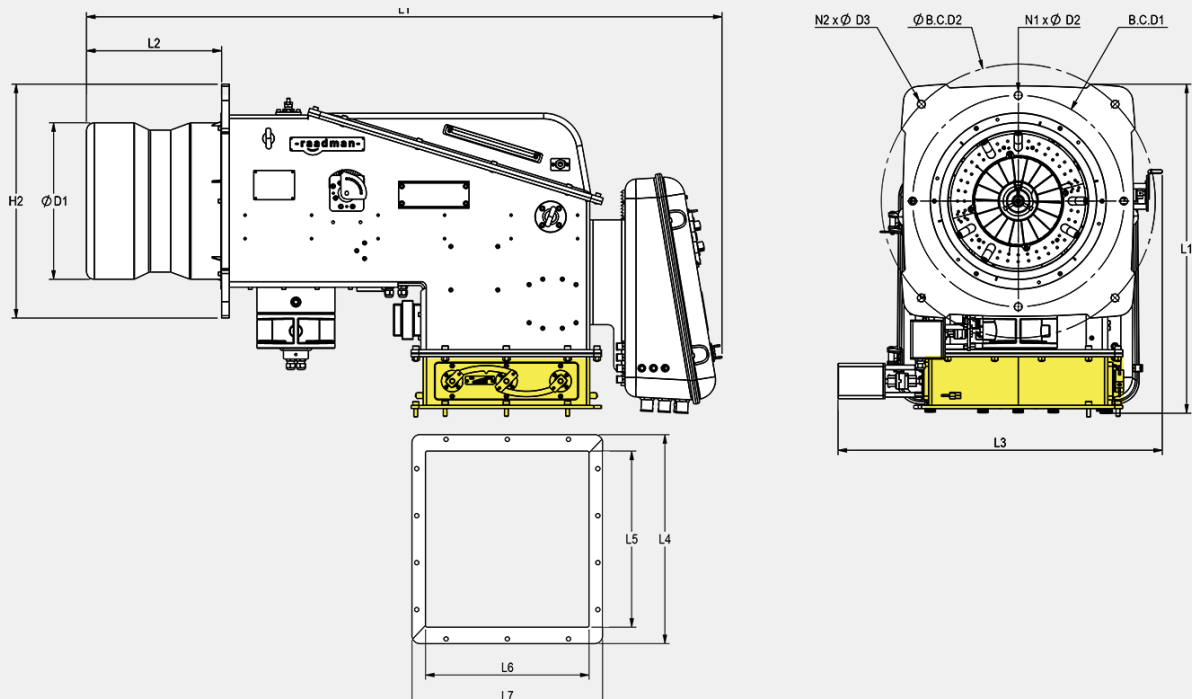

Burner Type	L1	L2	L3	L4	L5	L6	L7	H1	H2	D1
RGB-M-705-DB-SF	1606	345	860	534	450	418	487	833	598	400
RGB-M-705-DB	1676	415	860	534	450	418	487	833	598	400
RGB-M-805-DB-SF	1606	345	860	534	450	418	487	833	598	400
RGB-M-805-DB	1676	415	860	534	450	418	487	833	598	400
RGB-M-950-DB	1845	427	881	584	500	418	487	881	660	480
RGB-M-1050-DB	1845	427	881	584	500	418	487	881	660	480
RGB-M-1250-DB	1783	367	908	584	500	418	487	920	660	480
RGB-M-1350-DB	1783	367	908	584	500	418	487	920	660	480
RGB-M-1550-DB	2196	510	999	650	556	556	650	1256	872	590
RGB-M-1750-DB	2196	510	999	650	556	556	650	1256	872	590
RGB-M-2250-DB	2196	508	1076	650	556	556	650	1256	872	590
RGB-M-2550-DB	2196	508	1076	650	556	556	650	1256	872	590
RGB-M-3250-DB	2192	500	1071	650	556	556	650	1256	872	618

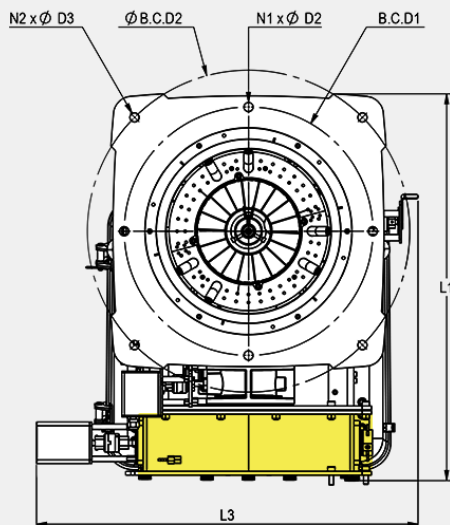

Burner Type	D2	D3	N1	N2	B.C.D1	B.C.D2
RGB-M-705-DB	21	21	4	4	540	700
RGB-M-805-DB	21	21	4	4	540	700
RGB-M-950-DB	20	20	4	4	590	790
RGB-M-1050-DB	20	20	4	4	590	790
RGB-M-1250-DB	20	20	4	4	590	790
RGB-M-1350-DB	20	20	4	4	590	790
RGB-M-1550-DB	20	20	4	8	770	940
RGB-M-1750-DB	20	20	4	8	770	940
RGB-M-2250-DB	20	20	4	8	770	940
RGB-M-2550-DB	20	20	4	8	770	940
RGB-M-3250-DB	20	20	4	8	770	940

Note:

Since the DB-Series burners are project-based, we strongly recommend to contact us for exact dimensions for superior plant arrangements.



- raadman -



## RLGB-M/M-X-DB series raadman burner

raadman dual block dual fuel burners cover a firing range of 7000 to 25000 kW and the model and capacity of dual block dual fuel burners are presented in the table.

\* Special note: Turn-down ratio higher than (1:8, 1:9, 1:10, etc.) are accessible for the burner with the head actuator. Otherwise, without a head actuator, the maximum turn-down ratio is 1:6.

Burner	Capacity (kW)	Turn down*
RLGB-M/M-705-DB-SF	NG:1000-7000	1:7
RLGB-M/M-705-DB	LFO: 1400-7000	
RLGB-M/M-805-DB-SF	NG:1000-8000	1:8
RLGB-M/M-805	LFO:1600-8000	
RLGB-M/M-950-DB	NG:1000-9000 LFO: 1800-9000	1:9
RLGB-M/M-1050-DB	NG:1000-10500 LFO:2100-10500	1:10
RLGB-M/M-1250-DB	NG:1200-12000 LFO:2400-12000	1:10
RLGB-M/M-1350-DB	NG:1350-13500 LFO:2600-13000	1:10
RLGB-M/M-1550-DB	NG:1900-15000 LFO:3000-15000	1:8
RLGB-M/M-1750-DB	NG:2150-17000 LFO:3400-17000	1:8
RLGB-M/M-2250-DB	NG:2200-22000 LFO:4400-22000	1:8
RLGB-M/M-2550-DB	NG:2200-25000 LFO:5000-23700	1:8





# General dimension: RLGB-M/M-X-DB series

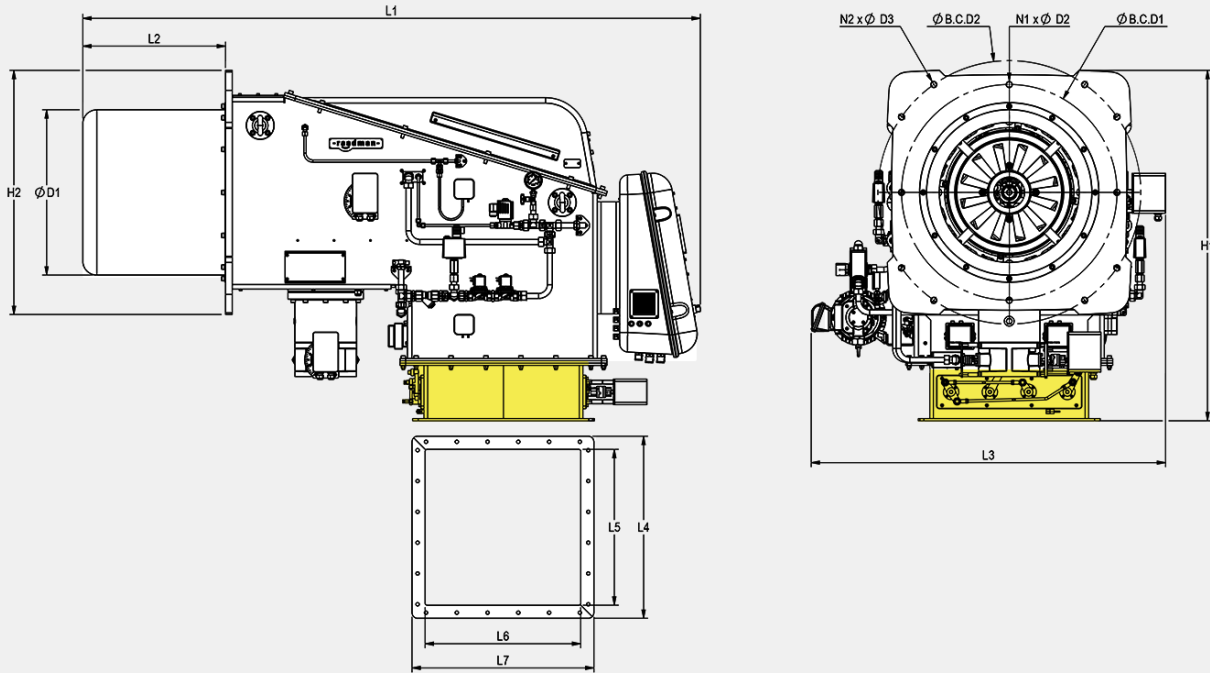

Burner Type	L1	L2	L3	L4	L5	L6	L7	H1	H2	D1
RLGB-M/M-705-DB-SF	1606	345	948	534	450	418	487	833	598	400
RLGB-M/M-705-DB	1676	415	948	534	450	418	487	833	598	400
RLGB-M/M-805-DB-SF	1606	345	948	534	450	418	487	833	598	400
RLGB-M/M-805-DB	1676	415	948	534	450	418	487	833	598	400
RLGB-M/M-950-DB	1845	427	1095	584	500	418	487	874	660	480
RLGB-M/M-1050-DB	1845	427	1095	584	500	418	487	874	660	480
RLGB-M/M-1250-DB	1800	367	1047	584	500	418	487	920	660	480
RLGB-M/M-1350-DB	1800	367	1047	584	500	418	487	920	660	480
RLGB-M/M-1550-DB	2196	510	1266	650	556	556	650	1256	872	590
RLGB-M/M-1750-DB	2196	510	1266	650	556	556	650	1256	872	590
RLGB-M/M-2250-DB	2196	508	1345	650	556	556	650	1256	872	590
RLGB-M/M-2550-DB	2196	508	1345	650	556	556	650	1256	872	590

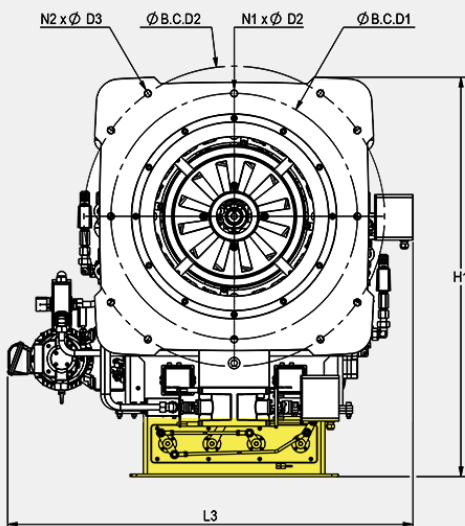

Burner Type	D2	D3	N1	N2	B.C.D1	B.C.D2
RLGB-M/M-705-DB	21	21	4	4	540	700
RLGB-M/M-805-DB	21	21	4	4	540	700
RLGB-M/M-950-DB	20	20	4	4	590	790
RLGB-M/M-1050-DB	20	20	4	4	590	790
RLGB-M/M-1250-DB	20	20	4	4	590	790
RLGB-M/M-1350-DB	20	20	4	4	590	790
RLGB-M/M-1550-DB	20	20	4	8	770	940
RLGB-M/M-1750-DB	20	20	4	8	770	940
RLGB-M/M-2250-DB	20	20	4	8	770	940
RLGB-M/M-2550-DB	20	20	4	8	770	940

**Note:**

Since the DB-Series burners are project -based, we strongly recommend to contact us for exact dimensions for superior plant arrangements.



- raadman -





- raadman -

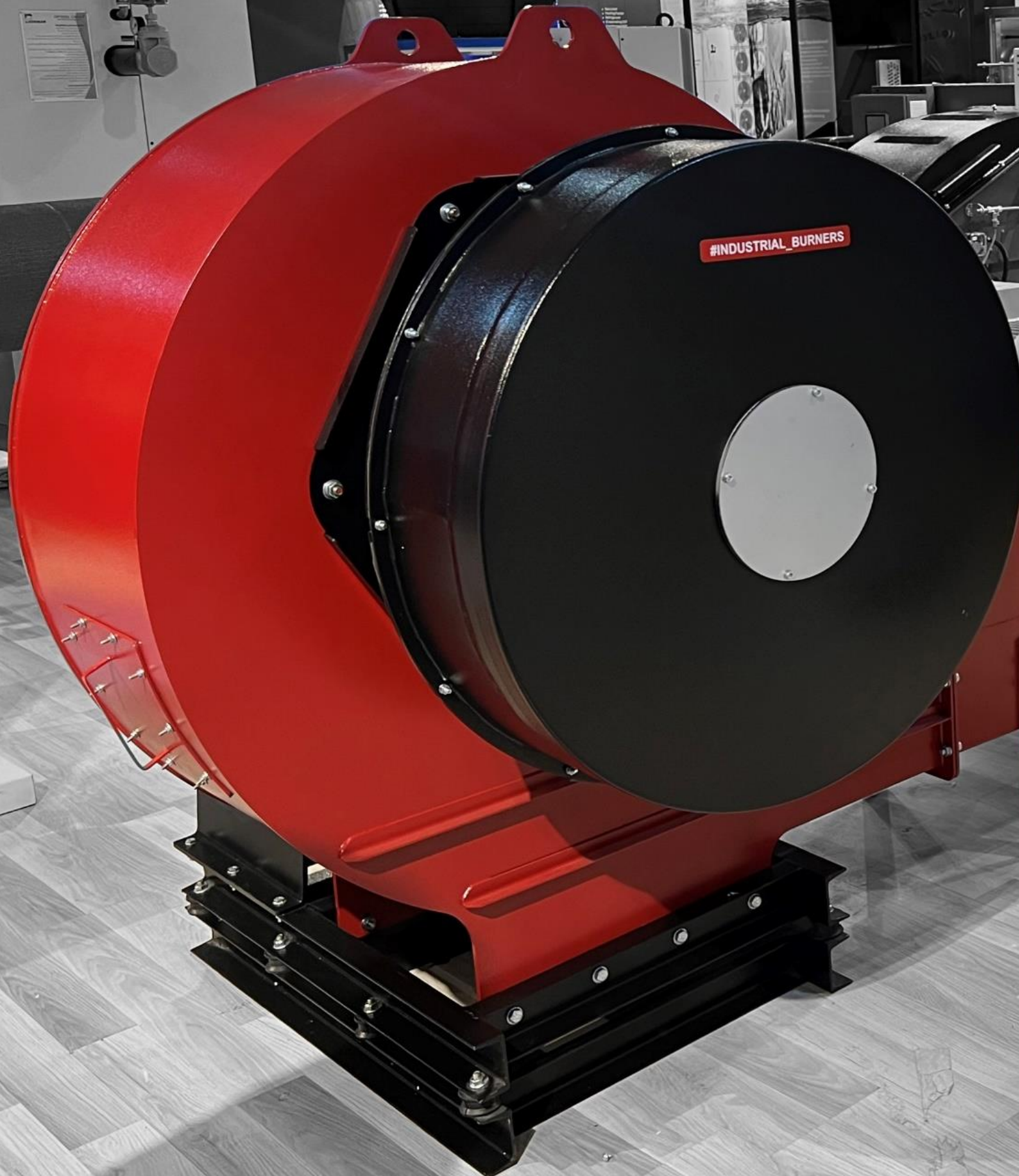

illman

CHILLMAN  
Coolest HVAC around

#INDUSTRIAL\_BURNERS

CHILLMAN  
Chiller Calibration & Servicing Equipment Available  
جهت اطلاع و سفارش تجهیزات و خدمات

Advanced  
Commissioning  
Services &  
Support





**WICKMANN**  
Intelligent Solutions  
Automation Control

**INDUSTRIAL BURNERS**  
Multi-fuel Gas Burner  
Power: 10.00 - 40.00 kW  
Capacity: 1.000 - 1.000 m³/h  
Max. pressure: 1.00 barg

- raadman -

- raadman -

# Gas train selection

**GT1** (Pressure input < 360 mbar, separated gas train, with pilot)

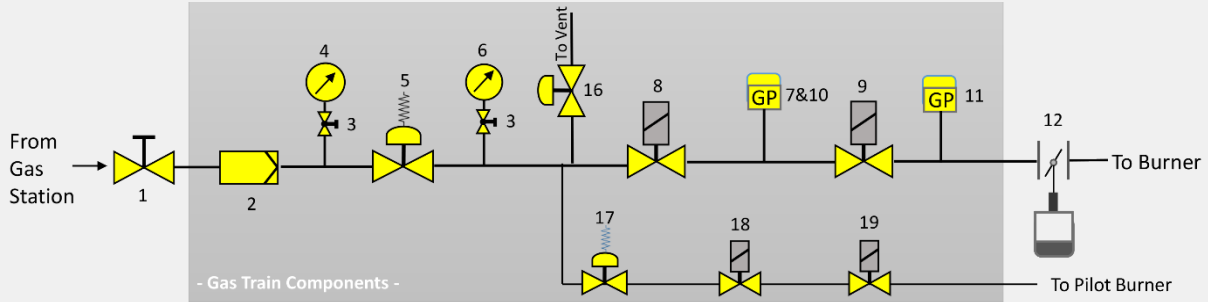

**GT2** (Pressure input < 360 mbar, multi block gas train, with pilot)

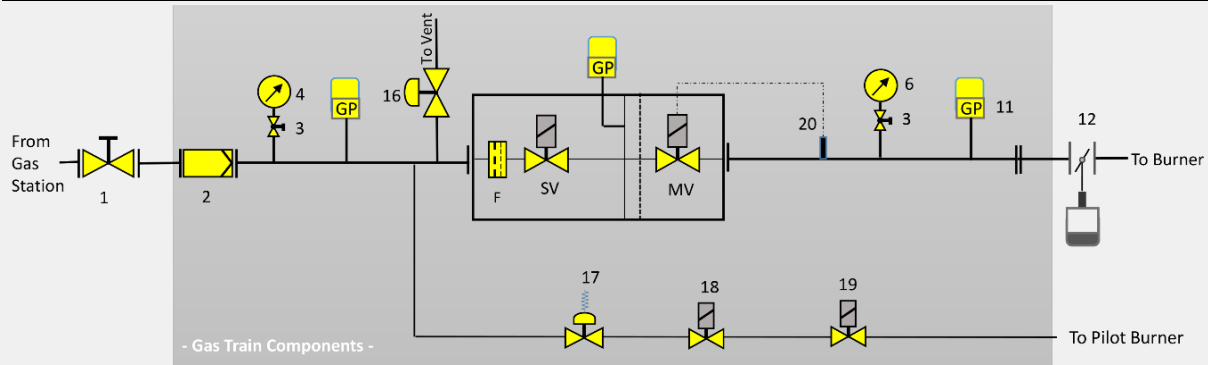

**GT3** (Pressure input > 360 mbar, separated gas train, with pilot)

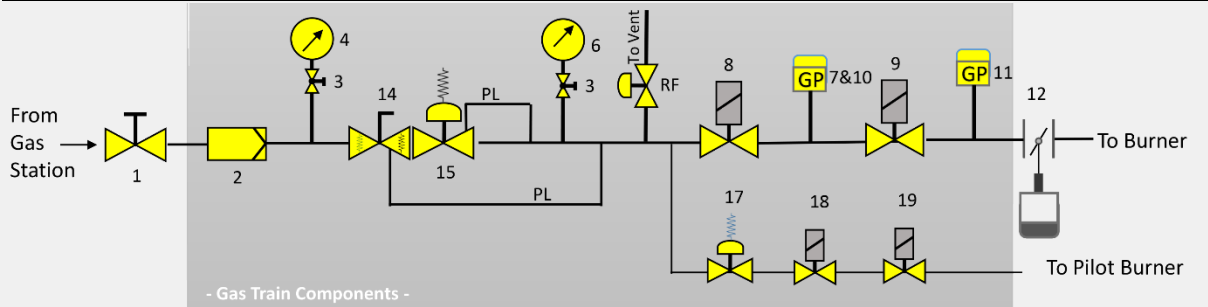

**GT4** (Pressure input > 360 mbar, multi block gas train, with pilot)

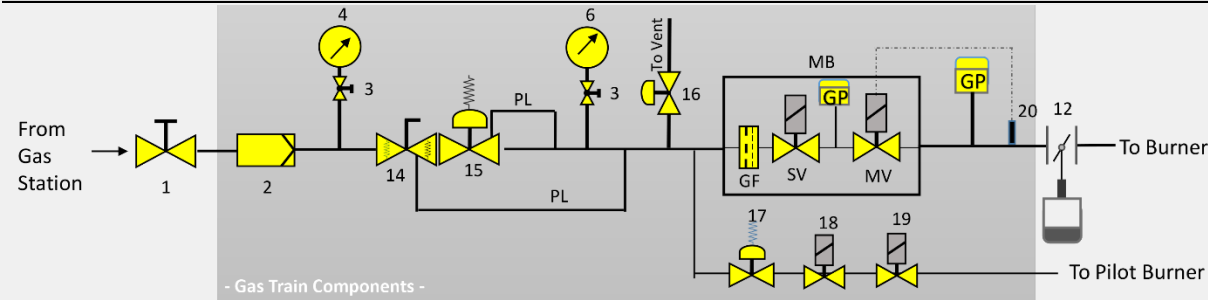

- |                                      |                                   |                             |
|--------------------------------------|-----------------------------------|-----------------------------|
| 1: Ball valve                        | 8: Safety gas valve               | 15: High pressure regulator |
| 2: Gas filter                        | 9: Main gas valve                 | 16: Relief valve            |
| 3: Push button valve                 | 10: Leak Test gas pressure switch | 17: Pilot regulator         |
| 4: Pressure Gauge                    | 11: Max. gas pressure switch      | 18: Pilot valve 1           |
| 5: Pressure regulator (Low-pressure) | 12: Butterfly valve               | 19: Pilot valve 2           |
| 6: Pressure gauge                    | 13: Multi-Block Solenoid Valve    | 20: Pressure transmitter    |
| 7: Min. gas pressure switch          | 14: Shut-off valve                |                             |



RGB-M-X-DB Series				
Burner	Gas Model	Gas Trian Size	$\Delta P$ B. V	$\Delta P$ C.H* (mbar)
RGB-M-705-DB-SF	GT-1	DN80	4	78
	GT-2	DN65		
	GT-3	DN80		
	GT-4	DN65		
RGB-M-705-DB	GT-1	DN80	4	85
	GT-2	DN65		
	GT-3	DN80		
	GT-4	DN65		
RGB-M-805-DB-SF	GT-1	DN100	5	90
	GT-2	DN80		
	GT-3	DN80		
	GT-4	DN80		
RGB-M-805-DB	GT-1	DN100	5	95
	GT-2	DN80		
	GT-3	DN80		
	GT-4	DN80		
RGB-M-950-DB	GT-1	DN100	5	85
	GT-2	DN80		
	GT-3	DN80		
	GT-4	DN80		
RGB-M-1050-DB	GT-2	DN100	5	110
	GT-3	DN100		
	GT-4	DN100		
RGB-M-1250-DB	GT-2	DN100	5	85
	GT-3	DN100		
	GT-4	DN100		
RGB-M-1350-DB	GT-2	DN100	6	100
	GT-3	DN100		
	GT-4	DN100		
RGB-M-1550-DB	GT-2	DN100	7	110
	GT-3	DN100		
	GT-4	DN100		
RGB-M-1750-DB	GT-2	DN100	7	125
	GT-3	DN100		
	GT-4	DN100		
RGB-M-2250-DB	GT-2	DN125	15	165
	GT-4	DN100		
RGB-M-2550-DB	GT-2	DN125	17	155
	GT-4	DN100		
RGB-M-3250-DB	GT-2	DN125	27	145
	GT-4	DN125		



<b>RGLB-M/M-X-DB Series</b>				
<b>Burner</b>	<b>Gas Model</b>	<b>Gas Trian Size</b>	<b>ΔP B. V</b>	<b>ΔP C.H* (mbar)</b>
RLGB-M/M-705-DB-SF	GT-1	DN80	4	78
	GT-2	DN65		
	GT-3	DN80		
	GT-4	DN65		
RLGB-M/M-705-DB	GT-1	DN80	4	85
	GT-2	DN65		
	GT-3	DN80		
	GT-4	DN65		
RLGB-M/M-805-DB-SF	GT-1	DN100	5	90
	GT-2	DN80		
	GT-3	DN80		
	GT-4	DN80		
RLGB-M/M-805-DB	GT-1	DN100	5	95
	GT-2	DN80		
	GT-3	DN80		
	GT-4	DN80		
RLGB-M/M-905-DB	GT-1	DN100	5	85
	GT-2	DN80		
	GT-3	DN80		
	GT-4	DN80		
RLGB-M/M-1050-DB	GT-2	DN80	5	110
	GT-3	DN80		
	GT-4	DN80		
RLGB-M/M-1250-DB	GT-2	DN100	5	85
	GT-3	DN100		
	GT-4	DN100		
RLGB-M/M-1350-DB	GT-2	DN100	6	100
	GT-3	DN100		
	GT-4	DN100		
RLGB-M/M-1550-DB	GT-2	DN100	7	110
	GT-3	DN100		
	GT-4	DN100		
RLGB-M/M-1750-DB	GT-2	DN100	7	125
	GT-3	DN100		
	GT-4	DN100		
RLGB-M/M-2250-DB	GT-2	DN125	15	165
	GT-4	DN125		
RLGB-M/M-2550-DB	GT-2	DN125	17	155
	GT-4	DN100		

**P**ACKMAN  
WWW.PACKMANGROUP.COM

Small technical label on the black panel.

Two red control panels with blue covers, each labeled RLGB-M/M-805. The left panel is open, revealing a motor, gauges, and wiring. The right panel is closed.

RLGB-M/M-805

RLGB-M/M-805



- raadman -





# Fire Heater Burner

Heat Rated Output: 500-2500 kW



- SMILE INTO THE FUTURE -

[www.raadmanburner.com](http://www.raadmanburner.com)

# Fire heater burner

Fire heater burners are put in the category of furnace Burners of Packman company. Fire heaters are widely used in petrochemical and oil refining industries in order to heat the fluid in the process to the desired temperature. This heating is produced by hot gases resulted from fuel combustion in burner or burners installed on a fire heater. The use of multi-burner systems generally depends on the required capacity, usage, structural geometry, and other effective parameters in a fire heater. Multi-burner systems are different from common boiler burners. Some of the differences are mentioned below.

1- unlike boiler burners which include a separate air block, gas, and oil piping, in fire heater burners, the air supply system, fuel supply gas, and oil burner control system are in common due to the number of burners that installed on a fire heater.

2- Each burner has a separate zone, which is branched off from the gas and Oil line and the main air for each zone.

3- The main block of burners only includes the main body, combustion head, inlets, and outlets.

According to the abovementioned points, a multi-burner dual fuel burner system includes different parts depending on the customer’s request, for instance, the main block of the burner, air block, oil station and electric panel that will be provided together with the burner. Also, Packman's technical team is ready to give a consultant and P&ID for the installation, placement and piping according to the circumstances and geometry of the related project.

Packman company's Modulating dual fuel fire heaters with a capacity of 2050 kW have performed well in tests and are ready to be delivered to the customers.

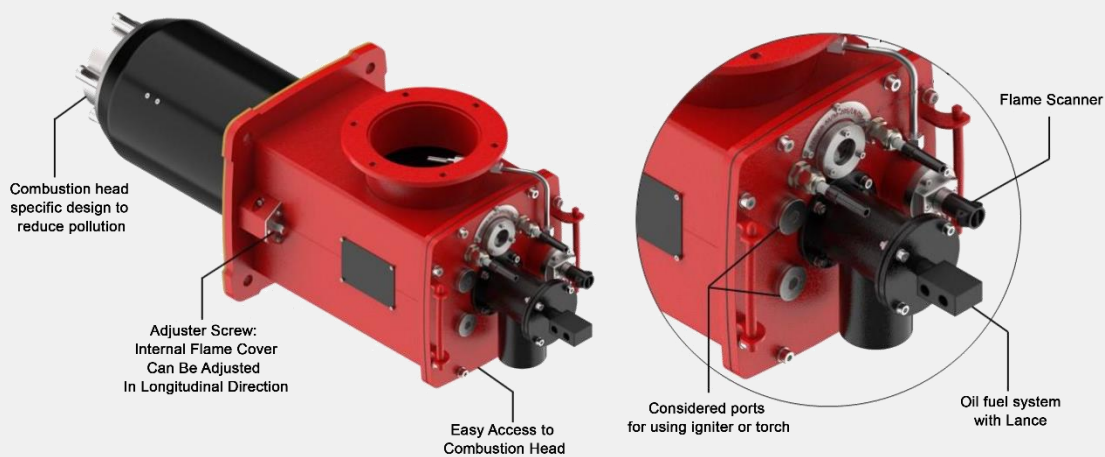



Modulating Fire Heater Burner  
Model: F-RLGB-MM-205LN-DB  
Gas Capacity: 490kW - 2250kW  
NOx emissions < 80 mg/kWh

GREENMAN  
Green technology, green business

#NEW





- raadman -



# Water Tube Burners

Heat Rated Output: 3200-60000 kW



- SMILE INTO THE FUTURE -

[www.raadmanburner.com](http://www.raadmanburner.com)

## Main features and advantages

The Raadman WT burner delivers high-efficiency performance in gas-fired package boilers with NO<sub>x</sub> emissions as low as 120 mg/kWh and CO emissions as 20 mg/kWh at 20 percent excess air (at 3 percent O<sub>2</sub>). Using advanced air-fuel staging techniques, the Raadman WT burner, operating with or without flue gas recirculation (FGR), meets the following benefits:

- Reduces NO<sub>x</sub> and CO emissions
- Robust and reliable combustion performance
- High turndown for maximum operating flexibility
- Reliable flame with a wide range of excess air operation
- Simultaneous gas and oil firing capability
- Maximum capacity up to 40 MW
- Advanced air-fuel staging and FGR for cost-efficient low NO<sub>x</sub> performance
- Advanced oil gun design with low atomizing steam usage
- Low CO, particulate and opacity emissions
- Reduced downtime, maintenance, fuel and operating costs
- Extremely stable combustion using adjustable swirler and burner head

### Main Sub-divisions:

- Air Register: Turbulence-free axial airflow, the optimized shape minimizes pressure loss through the burner and maximizes velocity.
- Swirler: Produces stable flames and enables thorough mixing.
- Throat: Precisely matched with the register and swirler design to provide an aerodynamically stabilized flame.
- Gas Burner: Unique injector orientation provides fuel staging within the flame envelope, reducing thermal NO<sub>x</sub> formation.
- Oil Burner: Advanced oil gun tip designs achieve precisely controlled flame geometry.
- Air box
- Fuel trains

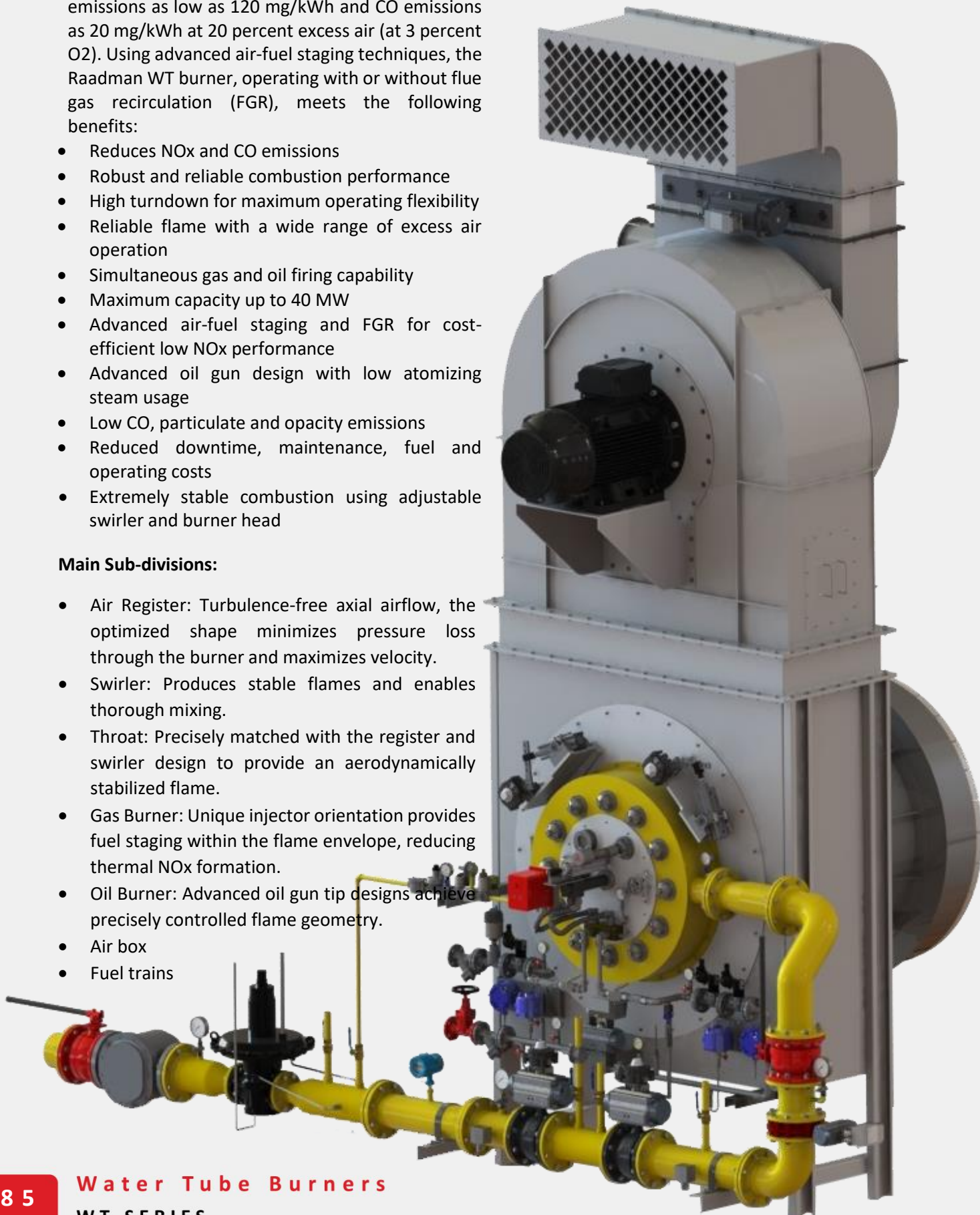



## Water tube boiler

The ability of water tube boilers to be designed without the use of excessively large and thick-walled pressure vessels makes these boilers particularly appropriate in applications that require dry, high-pressure, high-energy steam, including steam turbine power generation.

Owing to their superb working properties, the use of water tube boilers is highly preferred in the following major areas:

- Variety of process applications in industries
- Chemical processing divisions
- Pulp and Paper manufacturing plants
- Refining units
- Power Plants

Besides, they are frequently employed in power generation plants where large quantities of steam (ranging up to 500 kg/s) having high pressures i.e., approximately 16 megapascals (160 bar) and high temperatures reaching up to 550°C are generally required.

A water tube boiler can be defined as a Steam boiler in which the flow of water in the tubes, as well as hot gases, enclose the tubes. Unlike the fire tube boilers, this boiler attains high-pressures, as well as achieving high-steam capabilities. This is because of condensed tangential pressure on tubes which is known as hoop stress.

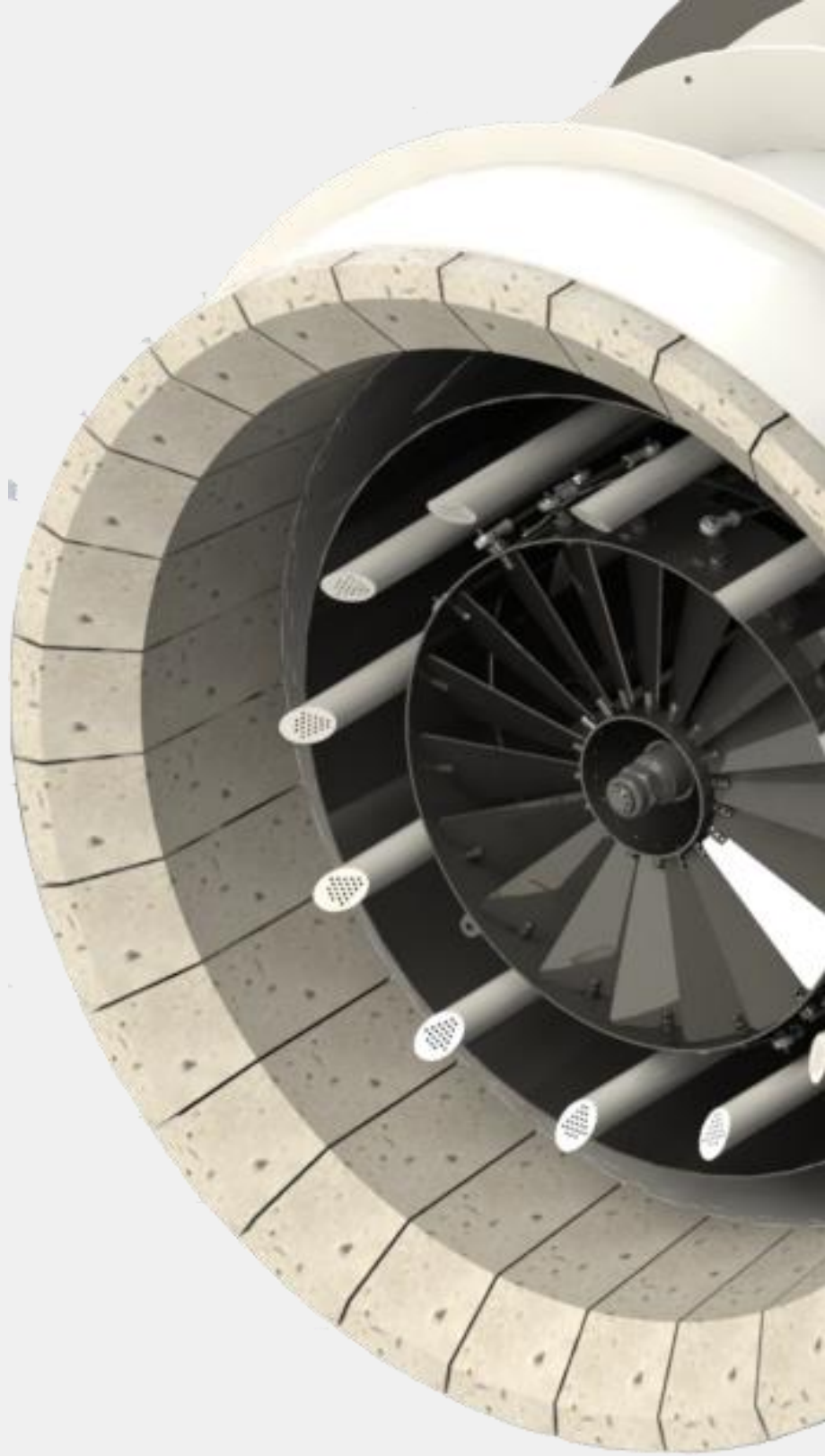

## Primary - Secondary air and air registers

The basis of design is to develop a stratified flame structure with specific sections of the flame operating fuel-rich and other sections operating fuel-lean. The burner design provides the internal staging of the flame to achieve reductions in NO<sub>x</sub> emissions while maintaining a stable flame.

Staging of the air into the combustion zone leads to slow down the combustion process and separate the flame into different zones, some of these zones are fuel-rich and some are fuel-lean.

The fuel-rich and fuel-lean zones both combust at lower peak temperatures than a uniform fuel air mixture, resulting in lower thermal NO<sub>x</sub> formation. Then the combustion products from these two zones combine to complete the combustion process and result in the completed oxidation of the fuel. By creating a fuel-rich zone in the front part of the flame, one can also reduce the conversion of fuel-bound nitrogen to NO<sub>x</sub> and thereby lower fuel NO<sub>x</sub> formation as well. raadman WT burners are equipped with two air registers suitable for any kind of liquid and/or gaseous fuel with the possibility of firing one or more fuels at the same time. Combustion air is divided into “primary” and “secondary” flows resulting in stratified combustion.

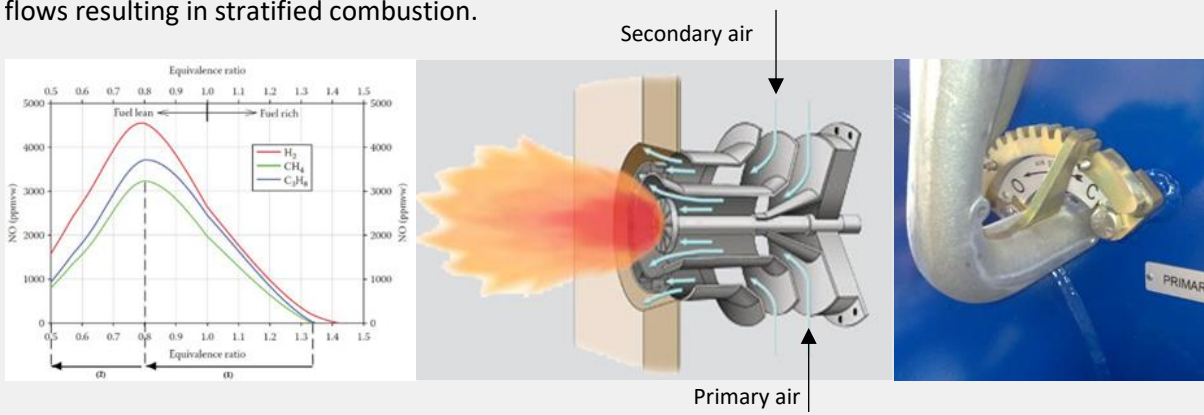

When a mixed gas/oil application is requested, a liquid atomizer replaces the central gas gun.

Air vorticity is generated and guaranteed by the vanes which formed each air register. The position of such vanes is set during the start - up phases and is important to control the flame intensity and shape which are different from one combustion chamber to another or from one fuel to another. The air registers vanes can be controlled manually or motorized or pneumatically depending on the type of hazardous area to adjust the amount of combustion air.

## Blade adjustment

A small amount of primary air, typically 10 to 20% of the total combustion air, is routed down the center of the burner. New burner designs employ a curved bladed swirler to impart rotational momentum to the primary air. The swirled primary air creates a rotational vortex in the front of the burner, which serves several functions. It entrains a portion of fuel, creating a fuel-rich region immediately in front of the burner. The swirling primary air also generates a reverse flow in the form of a self-generating annular vortex that helps to recirculate hot combustion gases within the flame zone, thereby providing additional ignition energy to the fuel-air mixture and increasing the mass flow in this region to limit peak temperatures. In addition to controlling NO<sub>x</sub> formation, operating under fuel rich conditions results in the production of combustion intermediates that can lead to the destruction of previously formed NO<sub>x</sub>.

In a reducing environment, NO can act as an oxidizer to react with these combustion intermediates, resulting in the reduction of NO to N<sub>2</sub>. As such, NO, necessarily formed to meet the requirements of establishing a strong flame front that can be scavenged by this mechanism. To achieve complete fuel burnout at minimum excess air, the burner design must provide fuel-lean zones to directly interact with the center fuel-rich sections. Creating a secondary air zone where the majority of the combustion air is introduced (65 to 90%) accomplishes this. The air injected into this zone is typically injected axially, with little or no swirl.

Blade angle is adjusted with axial movement of the rod connected to an annular plate. Annular plate is linked with swirler vanes that adjust their angle. Also, adjusted blades can control the flame dimensions.





## Flame shape dimension

Burners have different flames depending on their utilizations. While fire tube boilers require a long flame with a small diameter, water tube boilers often require short flame but large diameter burners. In general, the flame length of water tube burners is 2 to 2.5 times as the flame diameter.

raadman WT burners have a ball shaped flame with substantial swirl (swirl number is higher than 0.6). The flame has hot reverse flow into the center and cold forward flow at sides. There is intense mixing and the secondary jet velocity is more than the primary jet velocity. The flame is used for combustion chambers which are more or less cubicle in shape.

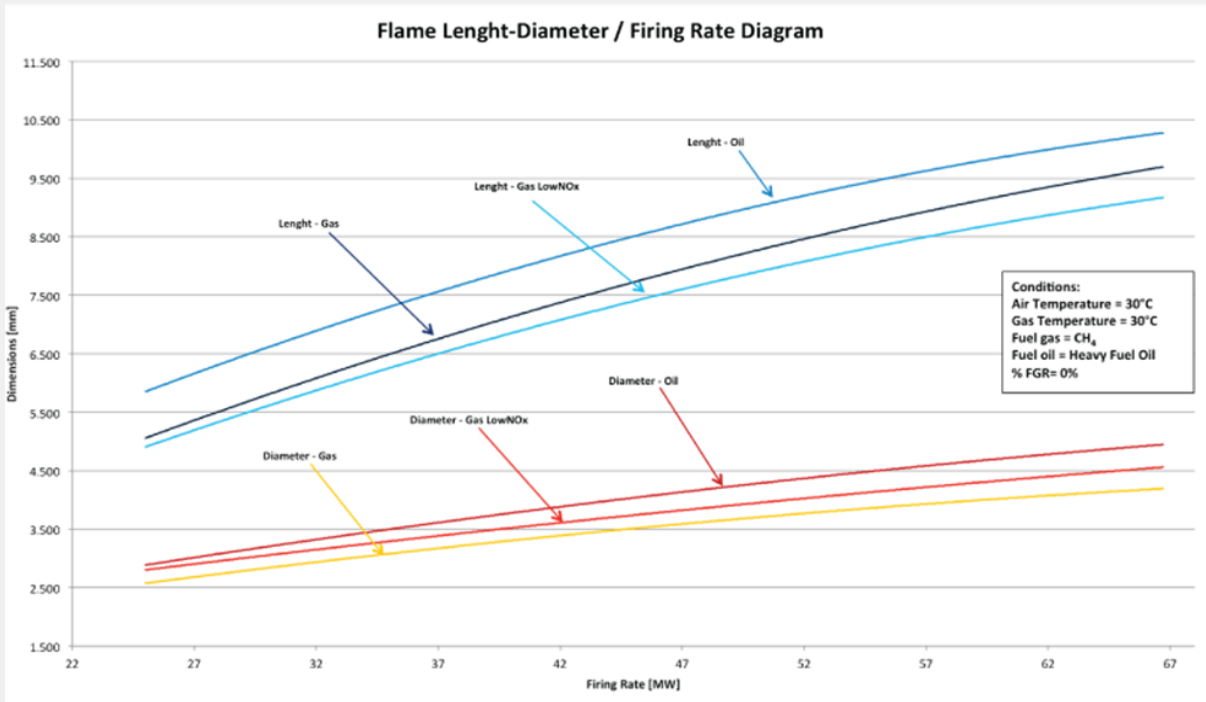

Using the unlimited subdivide flames, with a single combustion air register, we can offer any flame shapes for a much better combustion fitted the chamber of the target boiler.

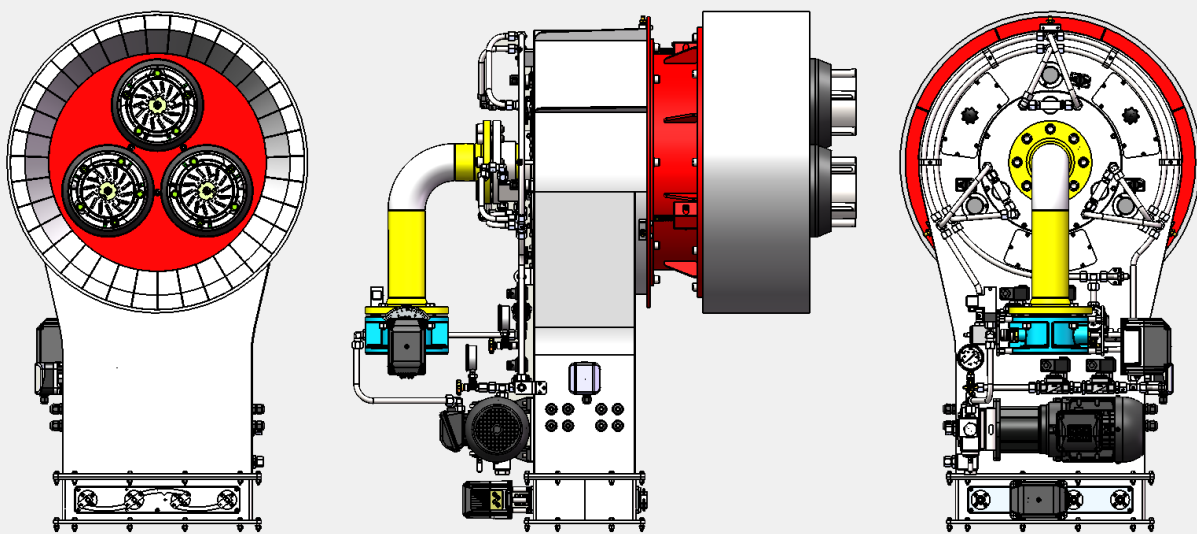

- raadman -

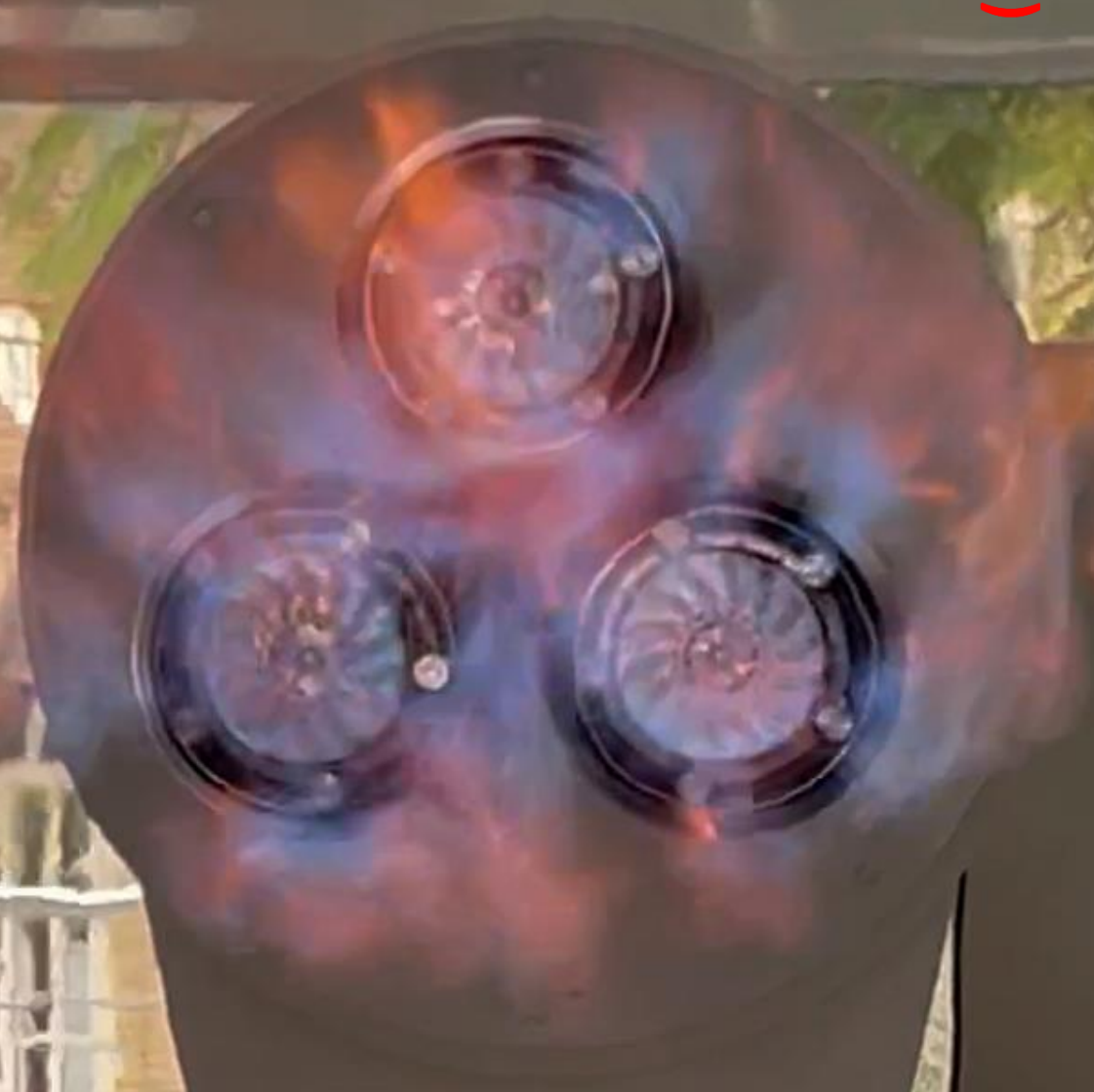

## raadman WT burner for multi-burner boilers

To achieve higher capacities, we use several burners in industrial water tube burners. In Industrial boilers, the simultaneous use of two burners is common, the flame shape of each is adjusted using air register vanes and swirler. These boilers have a common air box that the whole boiler air enters this air box and by adjusting the air register and swirler the shape of flame and the heat capacity of each flame will be adjusted.

The shape of the flame is such that each burner has a separate small flame, but eventually all burners will have a single large flame.

As a result of many observations of multiple-burner, oil and gas firing equipment, on a wide range of boiler designs, it has been concluded that the proper airflow distribution to each burner is essential in order to control flame shape, flame length, excess air level, and overall combustion efficiency. Proper airflow distribution consists of equal combustion airflow between burners, uniform peripheral velocity distributions at the burner inlets, and the elimination of tangential velocities within each burner. If the unit has been designed with wind box FGR, the O<sub>2</sub> content must be equal between the burners, and this is accomplished by balancing the FGR distribution to each burner.

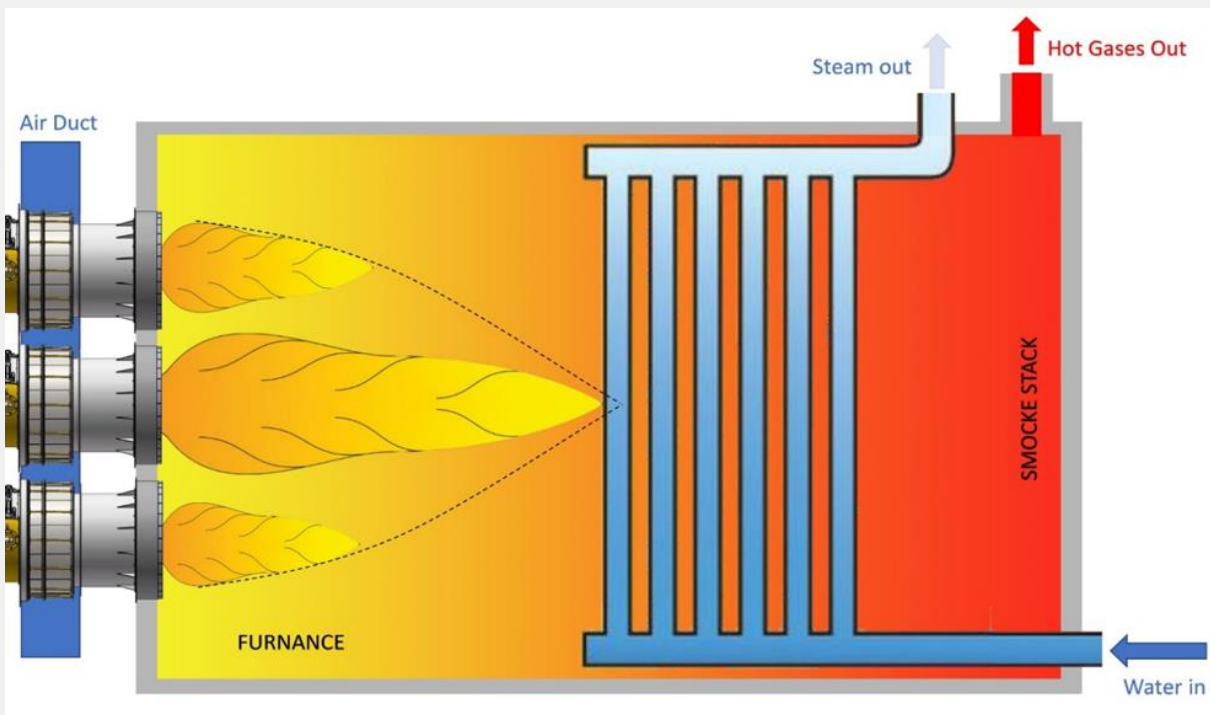



## Igniting technology

The most powerful ignitors are based on high energy systems developed over decades of experience in applications requiring safe and reliable operation, such as power generation plants and steam generating utilities.

The High Energy ignition systems ensure a number of robust intermittent sparks realized by the energy accumulated by a capacitor, providing more powerful ignition capacity compared to high tension arc electrodes. The Ignitors includes gas electric ignitors, light oil electric ignitors, without or with premixed air, suitable for continuous operation, as well as the direct spark ignitor for light up of heavy oil. Usually, the ignitors are an integral part of the supply of burners or combustion systems

The ignitors can be supplied with in-built flame scanners or ionization flame rods, with automatic retraction drivers and with power supply units for installation in any environment and hazardous area. High Energy Electric Ignitor has been capable of withstanding any temperature inside wind box which can be up to 350 °C, and the discharge head itself must withstand the very high radiation temperature close to the burner flame. The ignitor consists of three main parts, namely: the power needed for the discharge is generated in Control Box. The High Voltage Armored Cable used to carry this power to the ignitor. The discharge occurs in the Special Ignitor End in a semiconductor gap. We can provide ignitors for a wide range of application and for any kind of industrial process as industrial boilers for generating steam power in plants in which burners installed on front wall of boilers or on the other corners of the boilers (tangential combustion).

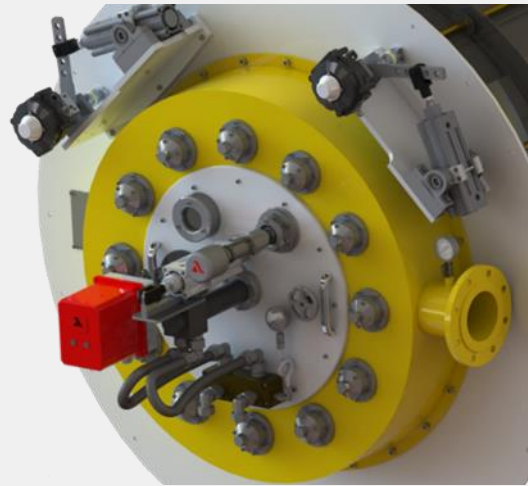



## Hazardous area

Fire and explosion are major safety concerns in industrial plants. No other aspect of industrial safety receives more attention in the form of codes, standards, technical papers, and engineering design. Regulatory bodies like the Occupational Safety and Health Administration (OSHA) have established systems that classify locations which exhibit potentially dangerous conditions to the degree of hazard presented.

Hazardous locations are areas where flammable liquids, gases or vapors or combustible dusts exist in sufficient quantities to produce an explosion or fire. In hazardous locations, specially -designed equipment and special installation techniques must be used to protect against the explosive and flammable potential of these substances.

Hazardous locations can also be described as locations where electrical equipment might be installed and, by their nature, might create a condition which could become explosive if the elements for ignition are present. Unfortunately, flammable substances are not always avoidable, e.g., methane and coal dust in mines. Therefore, it is of great importance that a user of electrical equipment, such as push buttons and pilot lights, be aware of the environment in which these products will be installed. The user's understanding of the hazard will help to ensure that the electrical equipment is properly selected, installed, and operated to provide a safe operating system.

There is a great variety of applications, especially in the chemical and petrochemical industries, that require explosion protected equipment. As a result, there have been principles and technologies developed to allow electrical instrumentation and control devices to be used even in environments where there is a danger of explosion.

Explosion hazards arising from handling of flammable gases, vapors, and dust are attributable to normal chemical and physical processes. Regulation on hazardous location by means of the Zone system have now been formulated by the International Electrotechnical Commission (IEC).

Hazardous areas are defined by considering different dangers presented by potentially explosive atmospheres. This enables protective measures to be taken which account for both cost and safety factors.

### **Zone 0**

In which ignitable concentrations of flammable gases or vapors are:

- Present continuously
- Present for long periods of time

### **Zone I**

In which ignitable concentrations of flammable gases or vapors:

- are Likely to exist under normal operating conditions
- may exist frequently because of repair, maintenance operations, or leakage

### **Zone II**

In which ignitable concentrations of flammable gases or vapors:

- are not likely to occur in normal operation
- occur for only a short period of time
- become hazardous only in case of an accident or some unusual operating condition



## Fuel types and simultaneous combustion

### Oil Burner: Precise Control of Flame Geometry

The steam or mechanical atomizers on steam boiler-burners control the flame geometry precisely that leads to a significant NO<sub>x</sub> reduction in comparison to the conventional oil-fired burners. The low-energy-consuming steam atomizer provides a turndown ratio as high as 8:1, with less than 7% steam-to-fuel oil ratio. This atomizer eliminates the need for a more complex constant differential system and operates at a constant pressure.

### Gas Burner: Setting New Standards in Staging

raadman WT burners effectively control NO<sub>x</sub> by staging fuel and air. Using both a multi-poker injector and center-fired gas burner, fuel-rich and fuel-lean zones are created within the flame envelope. The ratio of center-fired gas to poker gas, together with poker orientation and location, is carefully optimized for each application.

### Simultaneous gas and oil firing:

raadman WT burners offer the flexibility of simultaneous gas and oil firing. This gives you the options of firing oil and gas in the same burner, or gas in some and oil in others based on your specific needs. Our burners allow you switch fuels at various loads without affecting the boiler operation.

In the center of the register, the fuel oil sprayer with swirler is furnished. Surrounding the exterior of this swirler, multiple gas spuds (Spoke nozzle) are furnished, where intimate air/gas mixing is facilitated by primary air flows from outside the swirler.

- Wide turn down range 8:1
- Oil and gas firing in combination available
- LNG, LPG, HFO, and LFO gases fuel singular burning available
- Low NO<sub>x</sub> option available



# Gas train – meeting the requirements of NFPA-85

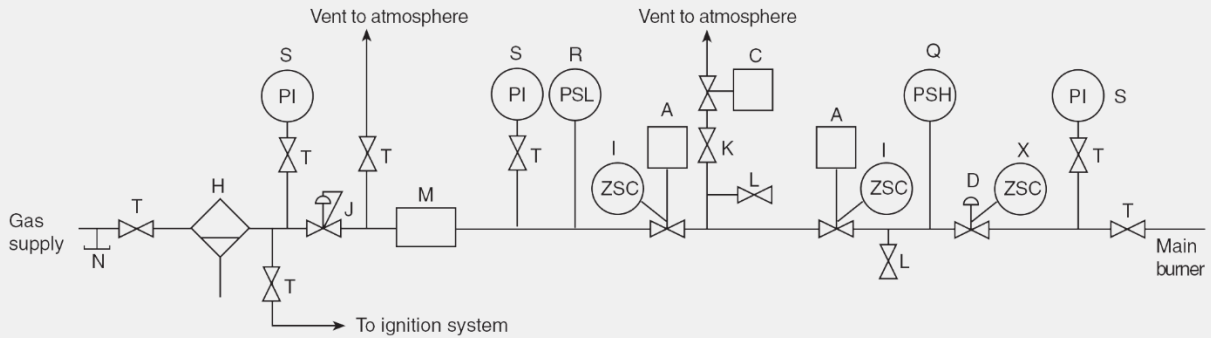

- A: Safety shutoff valve, spring closing (N.C)
  - C: Vent valve, spring opening (NO)
  - D: Gas flow control valve
  - H: Gas strainer
  - I: Closed Position interlock on valve safety shutoff
  - J: Constant gas pressure regulator valve
  - K: Vent line manual shutoff valve for leakage testing (locked or sealed open)
  - L: leakage test connection
  - M: Gas meter (optional)
  - N: Drip leg
  - Q: High gas pressure switch
  - R: Low gas pressure switch
  - S: Pressure gauge
  - T: Manual shutoff valve
  - X: Low fire start switch
- Note: NC = normally closed, deenergized  
NO = normally open, deenergized

**Note: Safety shutdown interlocks (not shown)**

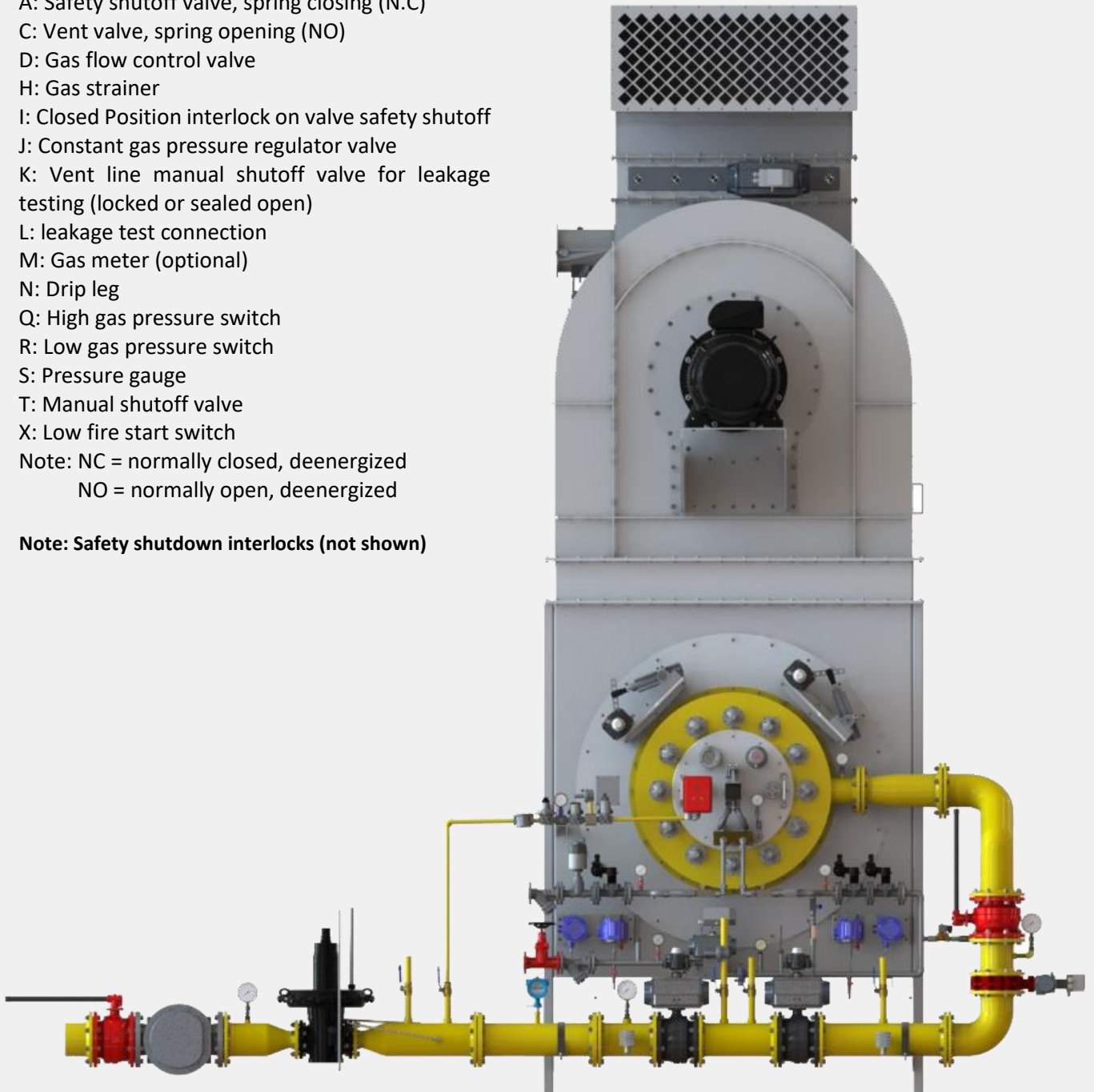

# Typical fuel and atomizing medium supply systems and safety controls for oil burner (Based on NFPA-85)

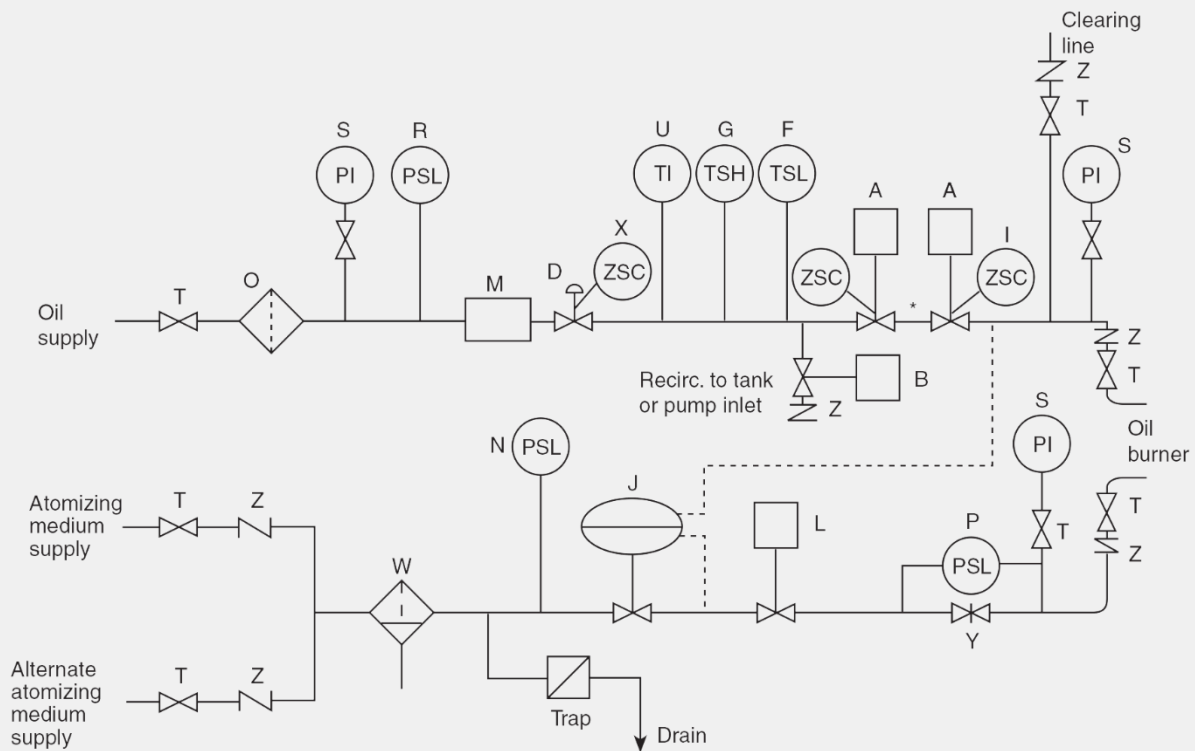

- A: Safety shutoff valve, spring closing (NC)
- B: Oil recirculation valve atomizing (NO) (optional for unheated oil)
- D: Oil flow control valve
- F: Low oil temperature switch (not applicable for unheated oil)
- G High oil temperature switch (not applicable for unheated oil)
- I: Closed position interlock on safety shutoff valve
- J: Atomizing medium differential control valve
- L: Automatic atomizing medium differential shutoff valve
- M: Oil meter (optional)
- N: Low atomizing medium pressure switch
- O: Oil strainer
- P: Atomizing medium flow interlock differential switch, or pressure interlock switch
- R: Low pressure switch
- S: Pressure gauge
- T: Manual shutoff valve
- U: Oil temperature gauge (optional for unheated oil)
- W: Atomizing medium strainer
- X: Low fire start switch
- Y: Atomizing medium flow orifice
- Z: Check valve

Note: NC= normally closed, deenergized  
 NO=normally open, deenergized

**Note: Safety shutdown interlocks (not shown)**





**We do our best to achieve the highest level of customer satisfaction.**

[www.raadmanburner.com](http://www.raadmanburner.com)



- raadman -

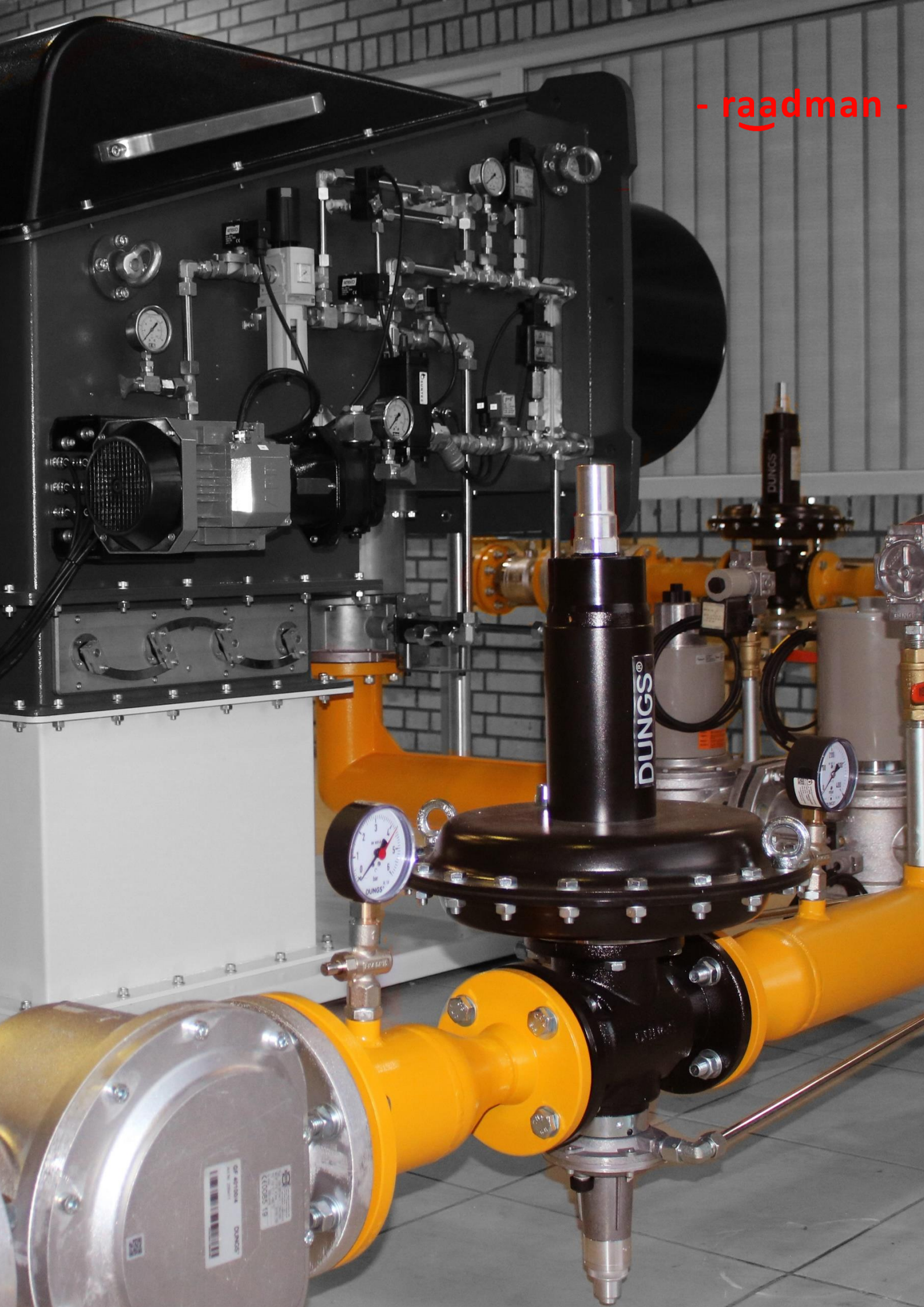

# Gas Train



- SMILE INTO THE FUTURE -

[www.raadmanburner.com](http://www.raadmanburner.com)



## Gas train components

Pressure reduction and regulation units allow to bring gas pressure available in the line to values suited to the specific application. Gas trains include a series of safety and control devices for gas feeding to the burner. They are constructed and supplied with two different selection options (separated or assembled units). The selection has to be made on the specific application (available pressure, installation chances,...). This permits to reach the best flexibility using pre-assembled units, which are also tested in the factory according to existing norms designed for easy installation.

### High-pressure gas supply, standard version.

Used when:

Input pressure is between 360 mbar and 4 bar.

The total pressure loss in gas valves, Butterfly valve and combustion chamber resistance does not exceed 200 mbar.

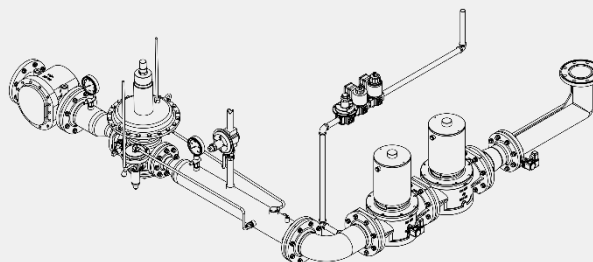

### High-pressure gas supply, Multi bloc version

Used when:

Input pressure is between 360 mbar and 4 bar.

The total pressure loss in gas valves, Butterfly valve and combustion chamber resistance does not exceed 450 mbar.

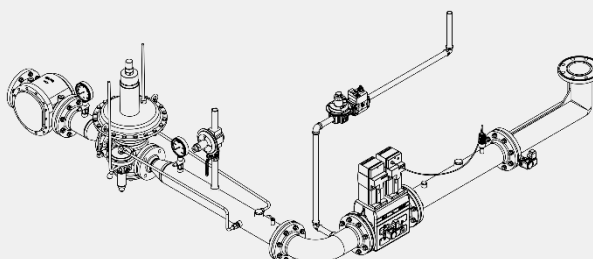

### Low-pressure gas supply

Used when:

Input pressure is < 360 bar

The total pressure loss in gas valves, Butterfly gate valve and combustion chamber resistance does not exceed 200 mbar.

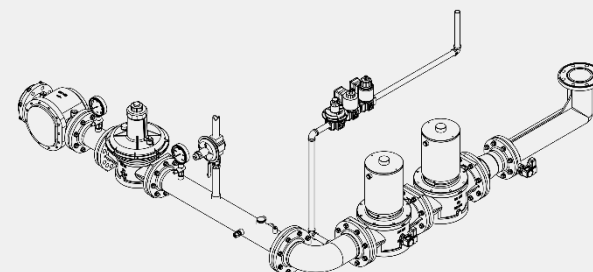

**Ball valve:** To isolate the system from any other train in boiler room (Excluded from the burner gas train)

**Filter:** To protect rest of the system from any debris or dust that may be carried with gas stream. Debris may for example consist of parts accidentally left in the pipe during construction.

**Regulator:** To keep the input pressure of a fluid to a desired value at its output. Based on the input pressure of the gas line, they are divided in two categories: Low pressure regulator, High pressure regulator.

**Safety Valve:** Single-stage solenoid valve, normally when closed, fast opening, fast closing, manual limitation of flowing gas volume by adjusting main volume.

**Main valve:** Single-stage solenoid valve, normally when closed, slow opening, fast closing. Opening time adjustment with fast stroke range, Main volume adjustment.

**Note:**

According to the BS-EN 676, valve proving system shall be used in burners with capacity above 1.2 MW. Consequently, MADAS-MTC10 or DungsVDK200 valve proving systems are highly recommended.

**Layout of the valve train**

On boilers with hinged doors, the valve train must be mounted on the opposite side to the boiler door hinges.

**Break points in the valve train**

Break points in the valve train should be provided to enable the door of the heat generator to be swung open. The main gas line is best separated at the compensator.

**Support of the valve train**

The valve train should be properly supported in accordance with the site conditions. See the raadman accessories list for various valve train support components.

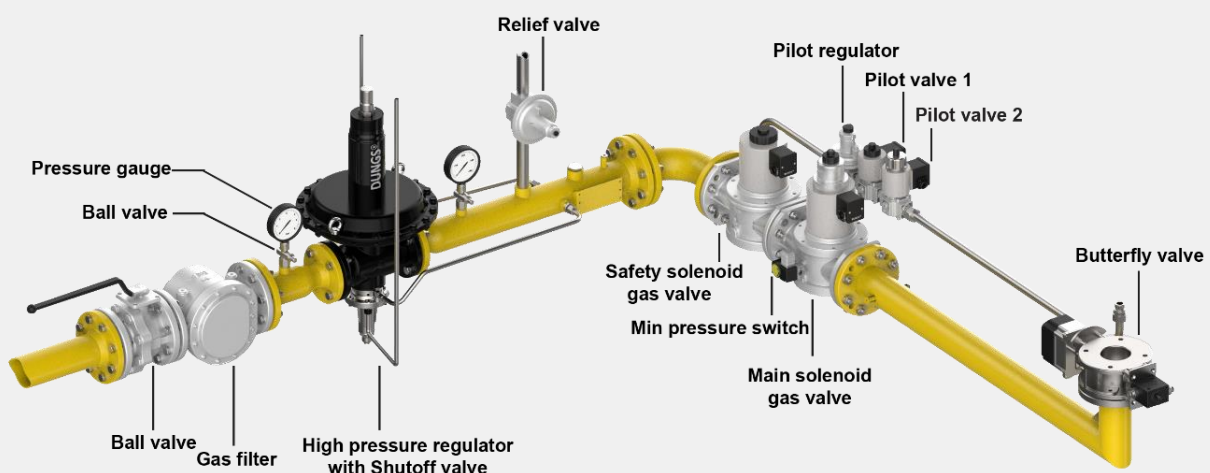





- raadman -



# Burner Ventilation System

Air Flow Rate: 8000-37000 m<sup>3</sup>/h



- SMILE INTO THE FUTURE -

[www.raadmanburner.com](http://www.raadmanburner.com)

## Burner Ventilation system

The Fan blade design is the result of extensive research and analysis resulting in high-performing and efficient centrifugal fans. Our R&D team will ensure the fans are complied with all safety certifications at the design stage regarding stability, reliability and safety.

Thanks to improved CFD simulations and FEM analysis, blade design simultaneously is optimized from structural and aerodynamic point of view. It also helps to provide customized solutions for market requirements. Our team surveys cover a complex step-by-step analysis of a centrifugal fan from its design to an advanced CFD & FEA simulation, including FSI and modal analysis.

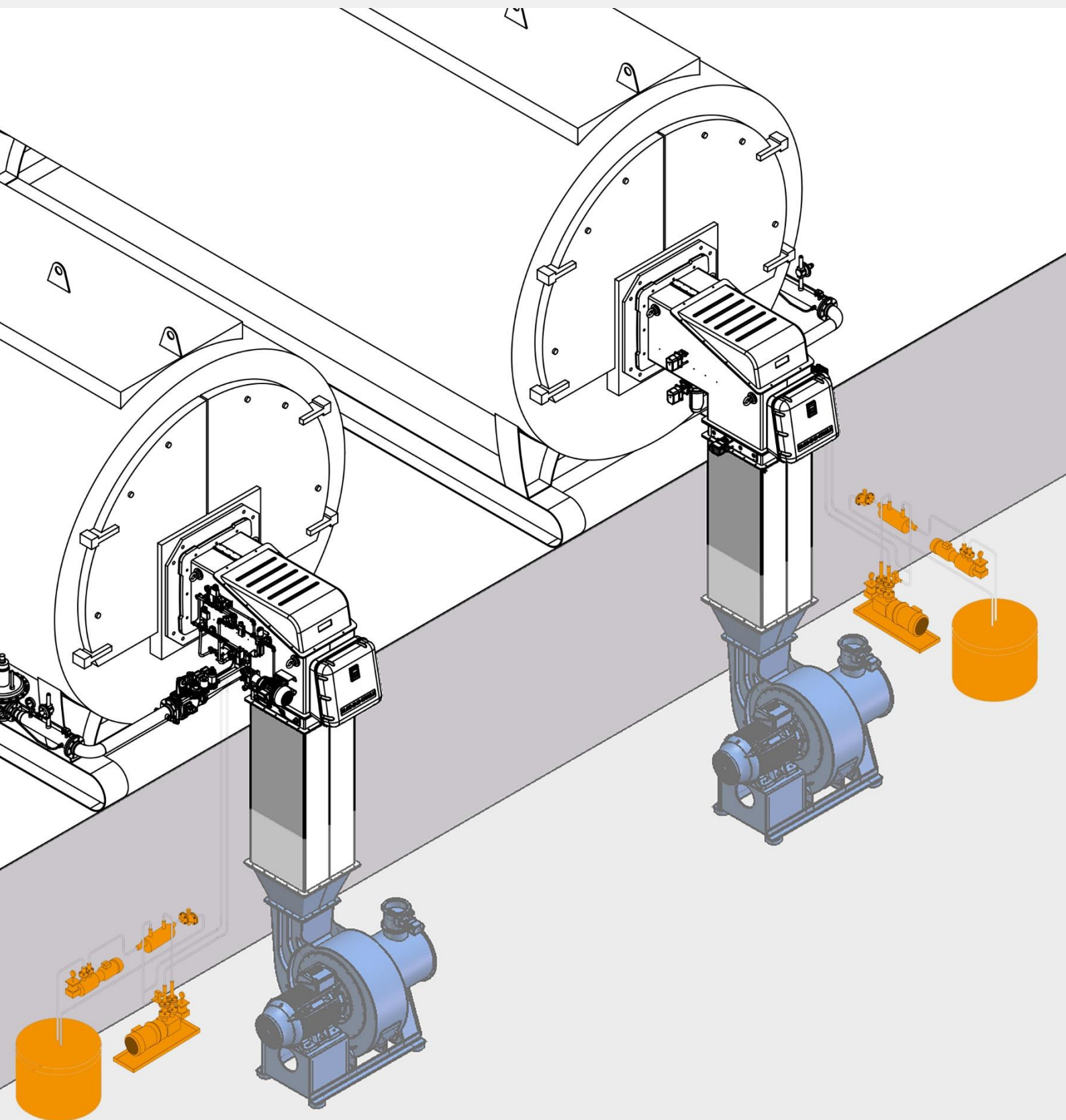

# Air block

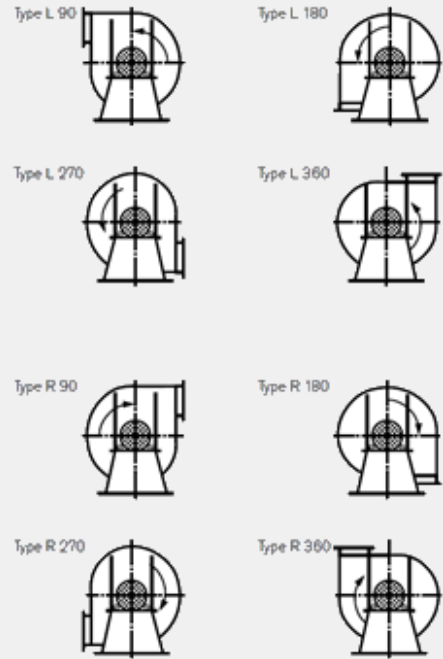

Note: The housing arrangement is to be considered as viewed from the drive side of the fan. Subsequent alteration of alignment of the fan to its base is not possible, as the two parts are welded together during manufacturing.

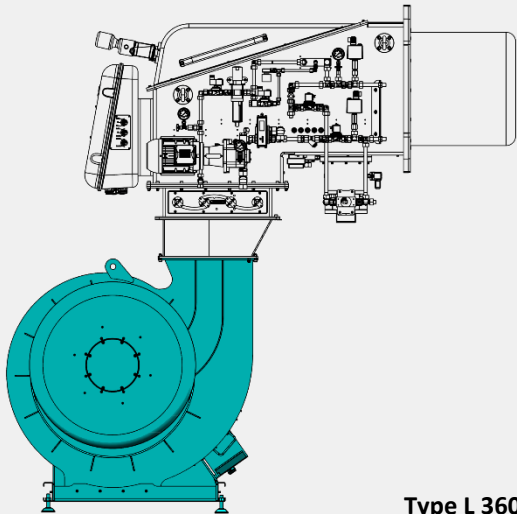

Type L 360

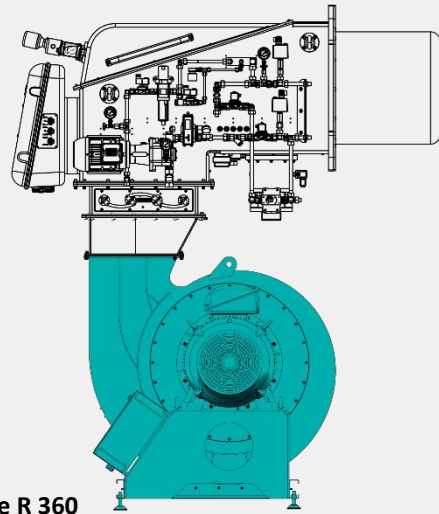

Type R 360

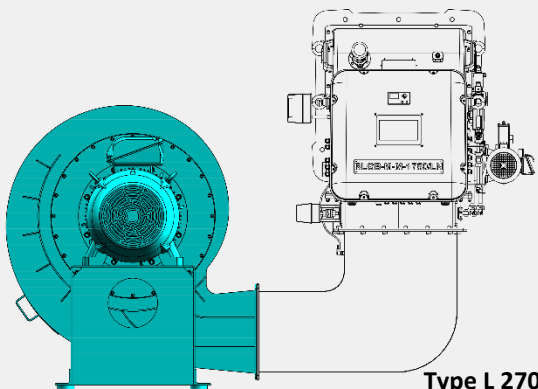

Type L 270

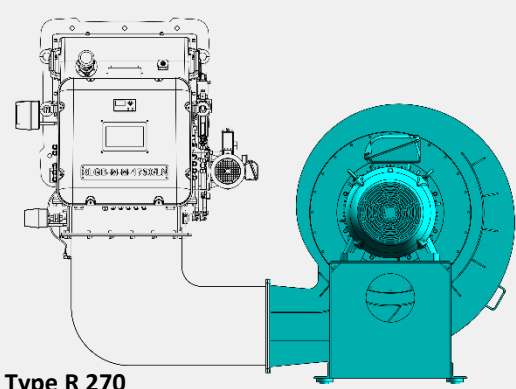

Type R 270



## BVS series range

In order to obtain a complete industrial combustion system, raadman burner is able to offer various components to be matched with the combustion heads of DB-Series, such as the centrifugal air fans. The fans supply the airflow to the combustion head through the adduction channel, with the appropriate technical features required from the application. The delivered air processed from the fan is in a correct proportion to the fuel in order to guarantee the required burner output with a safe operation.

BVS Model	Burner firing rate (kW)	Air flow rate (m <sup>3</sup> /h)	Air pressure drop (mbar)	Real power consumption (kW)	Available motor in marker (kW)
BVS-800/55/22	7000	8000	55	18	22
BVS-800/60/22	7000	8000	60	19	22
BVS-920/55/22	8000	9200	55	19	22
BVS-920/60/22	8000	9200	60	19	22
BVS-1030/60/30	9000	10300	60	28	30
BVS-1200/60/30	10500	12000	60	28	30
BVS-1380/65/37	12000	13800	65	33	37
BVS-1550/60/45	13500	15500	60	40	45
BVS-1720/60/45	15000	17200	60	41	45
BVS-1940/65/55	17000	20000	65	51	55
BVS-2580/65/75	22000	25800	65	70	75
BVS-2900/65/75	25000	29000	65	74.3	75
BVS-3700/90/132	32000	37000	90	130.3	132

# Noise suppression

Acoustic absorption refers to the process by which a material, structure, or object takes in sound energy when sound waves are encountered, as opposed to reflecting the energy. Some of the absorbed energy is transformed into heat and some is transmitted through the absorbing body. The energy transformed into heat is said to have been 'lost'.

When sound from a loudspeaker collides with the walls, the sound's energy is reflected, one part is transmitted, and the other part is absorbed into the walls. Just as the acoustic energy was transmitted through the air as pressure differentials (or deformations), the acoustic energy travels through the material which makes up the wall in the same manner. Deformation causes mechanical losses via converting part of the sound energy into heat, resulting in acoustic attenuation, mostly due to the wall's viscosity. Similar attenuation mechanisms apply for the air and any other medium through which sound passes.

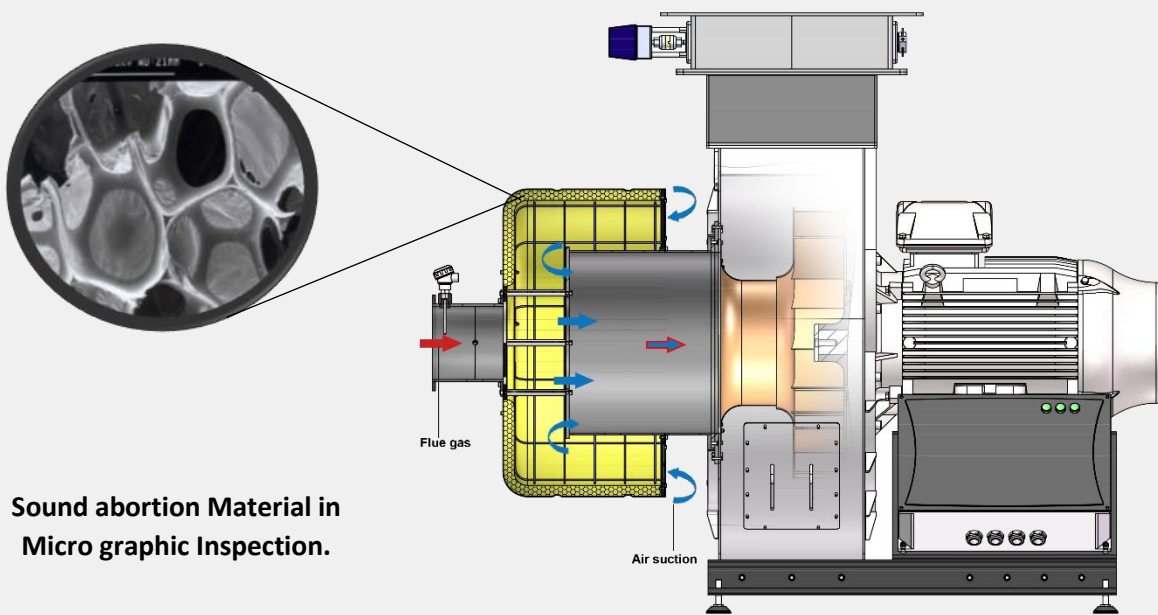

**Sound absorption Material in Micro graphic Inspection.**

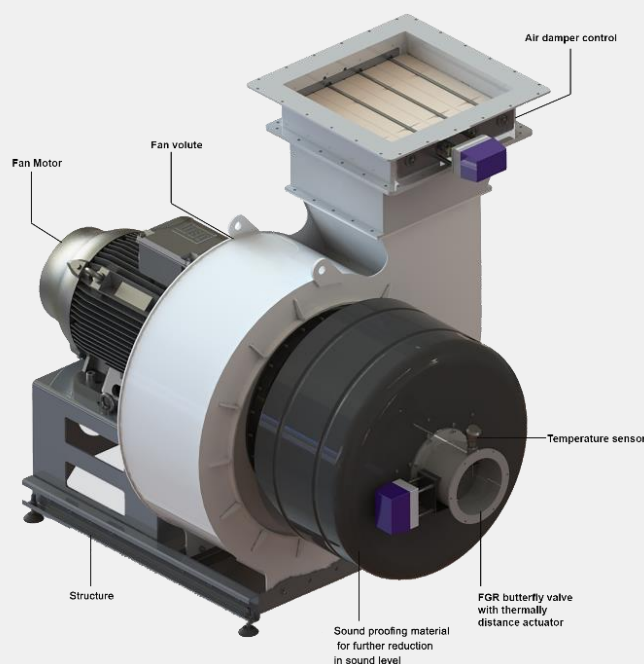

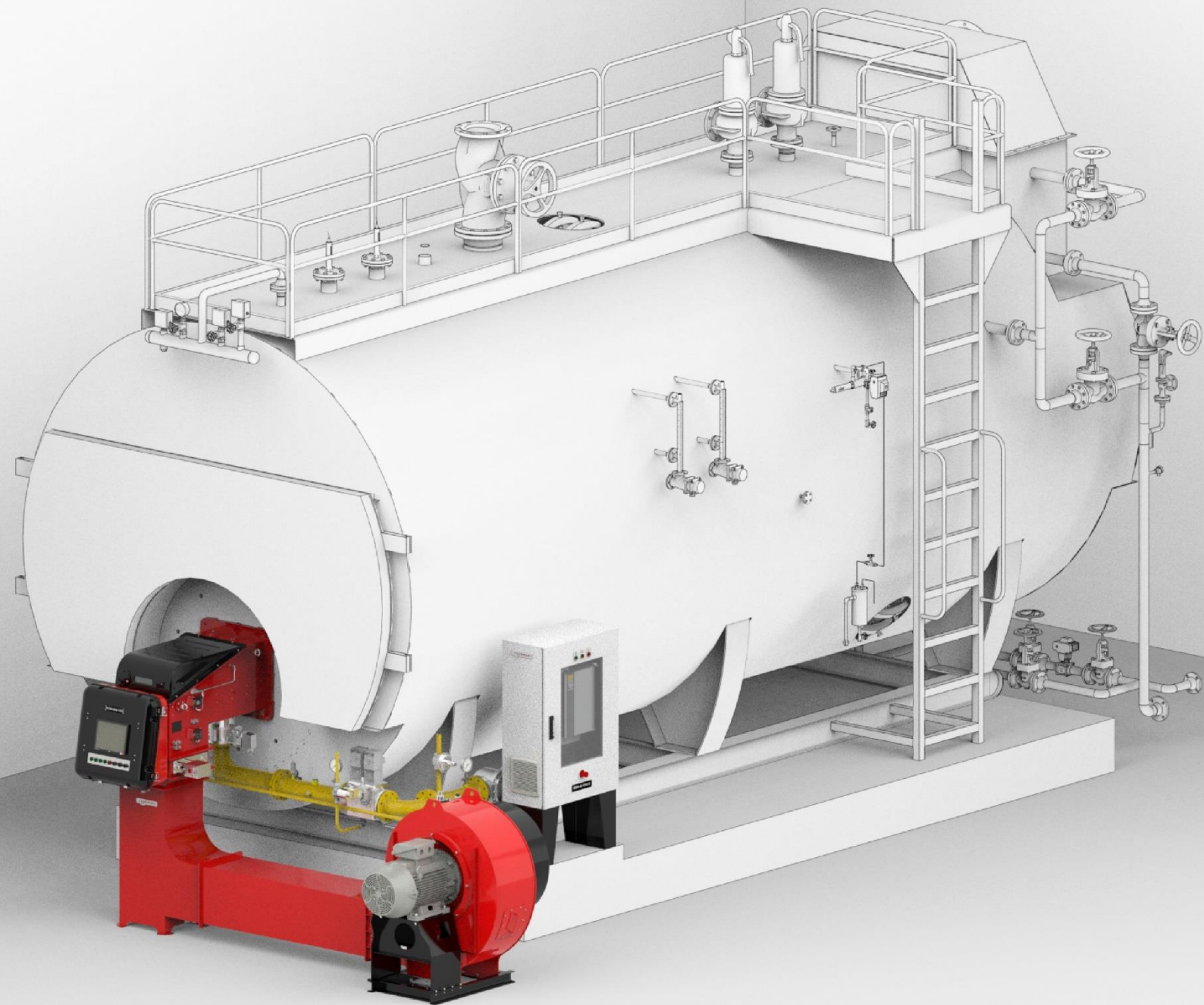

A good power system can increase the device operation and lifespan, prevent consecutive failures, reduce repair and maintenance costs, and provide superior customer comfort.



# Burner Ventilation Motor Starter

RMS Series



- SMILE INTO THE FUTURE -

[www.raadmanburner.com](http://www.raadmanburner.com)

# raadman burners ventilation motor starter

raadman factory produces burners with firing range of 100 kW to 60000 kW. In burners with ventilation motor capacity of 22kW and above, the power circuit and control circuit need to be installed separately due to destructive effects of electrical noise that power circuit or high voltage has on the control devices. With Regard to this reason, raadman motor starter (RMS) in which the power circuit is embedded, is introduced by the means of this technical document.

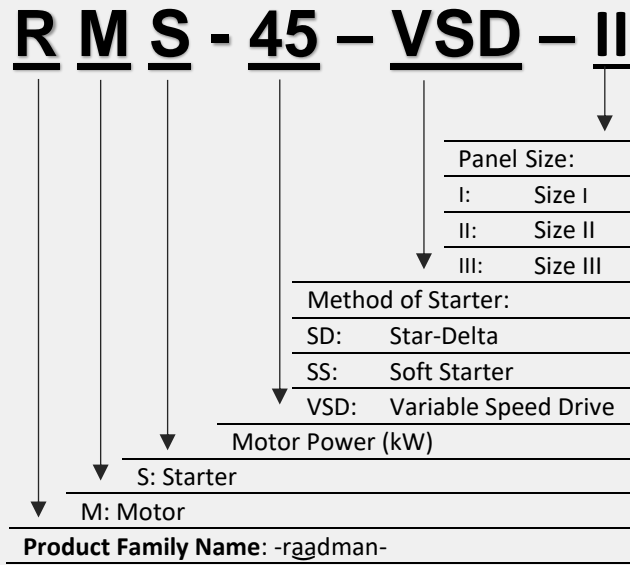

## Different starting methods



### Star-Delta:

A star-delta starter is the most commonly used method for starting a three-phase induction motor. In star-delta starting, an induction motor is connected via a star connection throughout the starting period. In order to use this starting method, the motor must be delta connected during a normal run.

This starting system has some disadvantages that are mentioned below:

- Overload current drawn from electric grid at the time of starting
- Current and mechanical shocks at the load torque starting moment
- Current and mechanical shocks to the motor at the moment of changing status from Star to Delta which reduces the motor useful lifespan
- by increasing the current range, the contactors and bimetal sizes are increased



### Soft Starter:

The soft starter makes use of the fact that when the motor voltage is low during start, the starting current and starting torque is also low. During the first part of the start, the voltage to the motor is so low that it is only able to adjust the play between the gear wheels or stretching driving belts, chains, etc. In other words, eliminating unnecessary jerks during the start. Gradually, the voltage and the torque increase so that the machinery starts to accelerate.

This method also has some drawbacks such as:

- high starting current (3 to 5 times of the rated current)
- limitations in number of starting times
- limitations in ambient temperature
- limitations in working cycle and rest period of the device
- high cost
- high sensitivity of power semiconductors

According to the abovementioned limitations, for using soft starter in starting the burner fan, it is necessary to choose a power range which is two times higher than motor power range. Moreover, the soft starter should be selected from among reputable brands



### Variable speed drive (VSD):

The frequency converter is also called VSD (Variable Speed Drive), VFD (Variable Frequency Drive) or simply Drive. The drive consists primarily of two parts; one part converts AC (50 or 60 Hz) to DC and the other part converts DC back to AC, but with a variable frequency of 0-250 Hz. The drive can control the motor speed by controlling the frequency.

During start, the drive increases the frequency from 0 Hz up to the network frequency (50 or 60 Hz). By increasing the frequency gradually, the motor can run at its rated speed for that frequency. Since the motor can run at its rated speed, the rated torque is available already from start and the current will be around the nominal current. Normally, the drive trips if the current reaches 1.5 times the rated current.

The followings are limitations of starting with a drive: causing noise and harmonics to the network (needs filter) and high cost



# Burner management system overview

Burner management consists of power circuit and control circuit. The control circuit controls the starter signal in the power circuit. The control circuit normally operates at a lower voltage than the power circuit. So, it is better to install power circuit and control circuit separately.

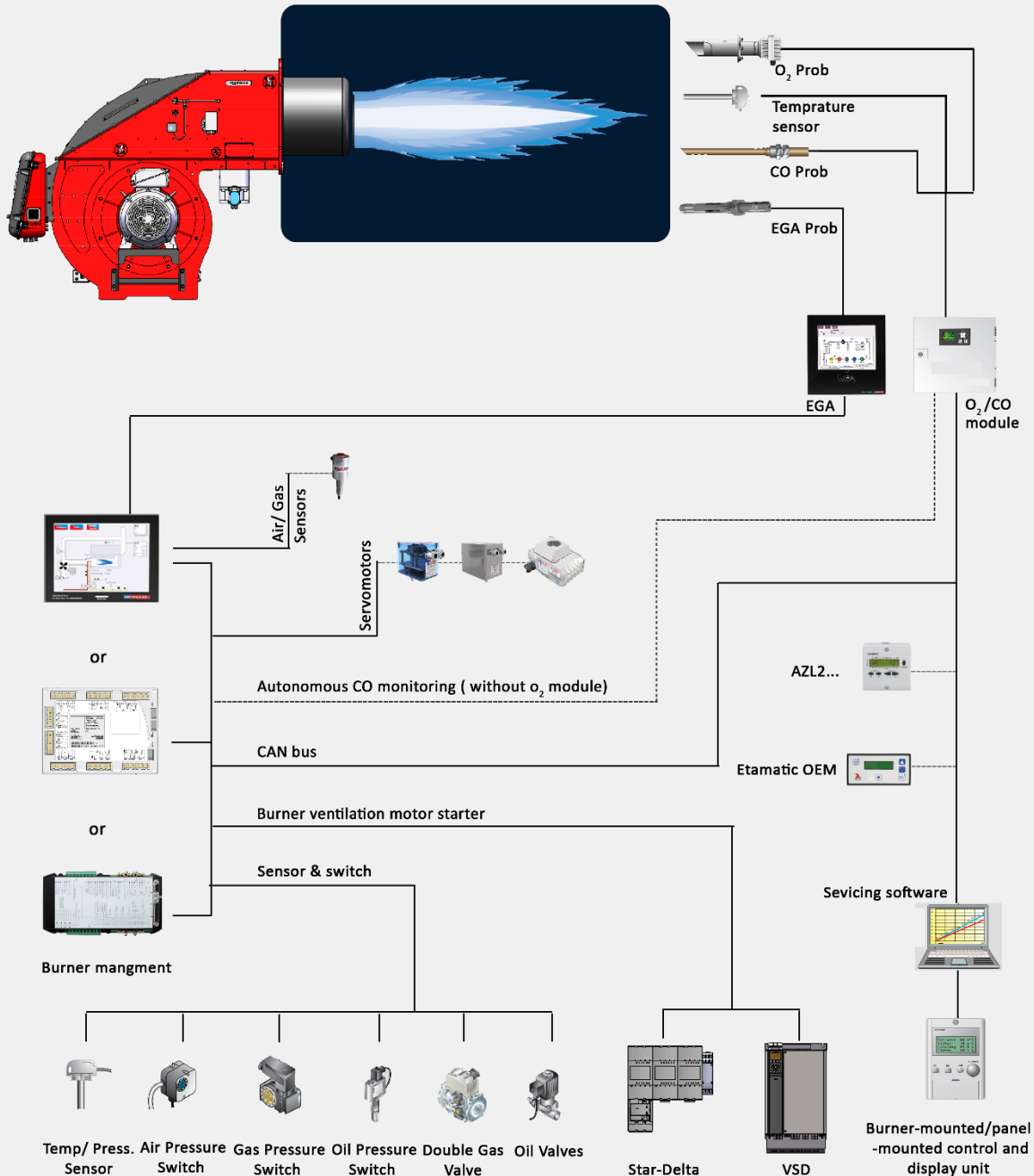



## RMS series range

In the following tables, different starting methods for ventilation motors of raadman burners together with appropriate panel sizes are suggested.

Note: In starting the ventilation motor by inverter, different brands can be used such as DELTA, XIMA, DANFOSS, and VORTEX. However, the preferred and standard brand by raadman is Vortex. Also, the preferred brand for starting by Star-Delta is Schneider.

RMS model	Motor(kW/PH/V/HZ/rpm)	Star-Delta*	size
RMS-22-SD-I	22/3/380-400/50/2840	LC1D50, LC1D50, LC1D40, LRD325, RE22R1QCMU	Size I
RMS-30-SD-I	30/3/380-400/50/2840	LC1D65, LC1D65, LC1D50, LRD340, RE22R1QCMU	Size I
RMS-37-SD-I	37/3/380-400/50/2840	LC1D65, LC1D65, LC1D50, LRD350, RE22R1QCMU	Size I
RMS-45-SD-I	45/3/380-400/50/2840	LC1D80, LC1D80, LC1D65, LRD3359, RE22R1QCMU	Size I
RMS-55-SD-I	55/3/380-400/50/2840	LC1D95, LC1D95, LC1D80, LRD3361, RE22R1QCMU	Size I
RMS-75-SD-I	75/3/380-400/50/2900	LC1D115, LC1D115, LC1D95, LRD4365, RE22R1QCMU	Size I
RMS-90-SD-I	90/3/380-400/50/2900	--	--
RMS-110-SD-I	110/3/380-400/50/2900	--	--

RMS model	Motor(kW/PH/V/HZ/rpm)	Inverter	size
RMS-22-VSD-I	22/3/380-400/50/2840	Vortex	Size I
RMS-30-VSD-II	30/3/380-400/50/2840	Vortex	Size II
RMS-37-VSD-II	37/3/380-400/50/2840	Vortex	Size II
RMS-45-VSD-II	45/3/380-400/50/2840	Vortex	Size II
RMS-55-VSD-II	55/3/380-400/50/2840	Vortex	Size II
RMS-75-VSD-II	75/3/380-400/50/2900	Vortex	Size II
RMS-90-VSD-II	90/3/380-400/50/2900	Vortex	Size II
RMS-110-VSD-III	110/3/380-400/50/2900	Vortex	Size III

- For all burners with ventilation motor above 22 kW, the accessories of power system are not included by the burners.
- We recommend to use VSD in order to control the noise level of the burners as well as enhancing the entire capabilities. All customers are welcome to handle the power system by themselves or place an order of RMS (Raadman Motor starter) with us.
- As stated above, we do not recommend start-delta starters for powers above 45 kW. In these cases, VSD is more recommended.
- RMS can also be supplied by soft-starters but it is not recommended.



## General dimension: RMS series

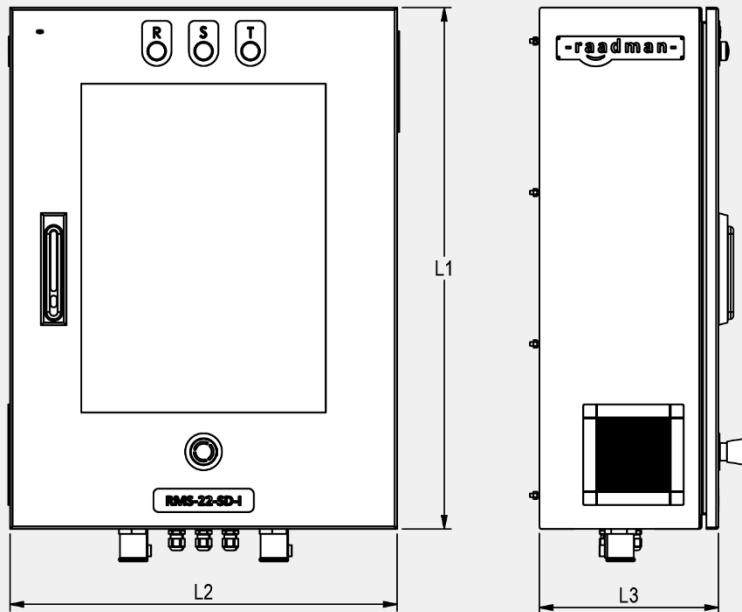

Panel Size	L1	L2	L3
Size I	777 mm	578 mm	268 mm
Size II	1160 mm	800 mm	389 mm
Size III	1260 mm	875 mm	410 mm

## RMS series components

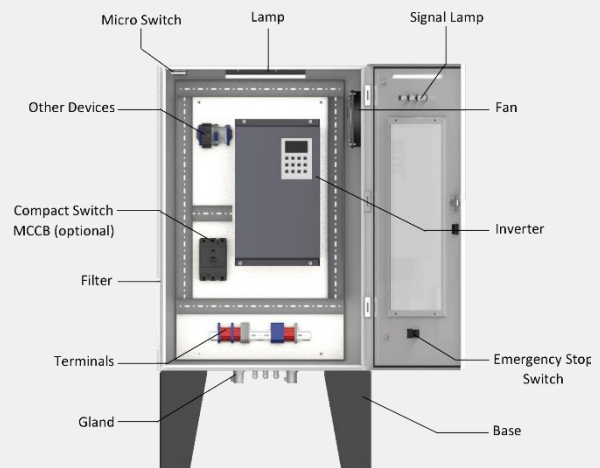
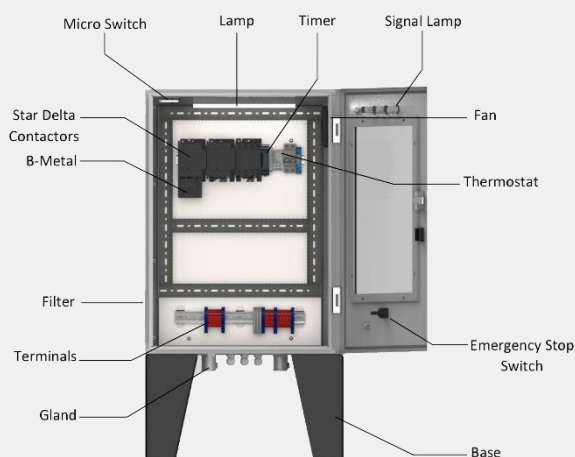

## RMS series installation

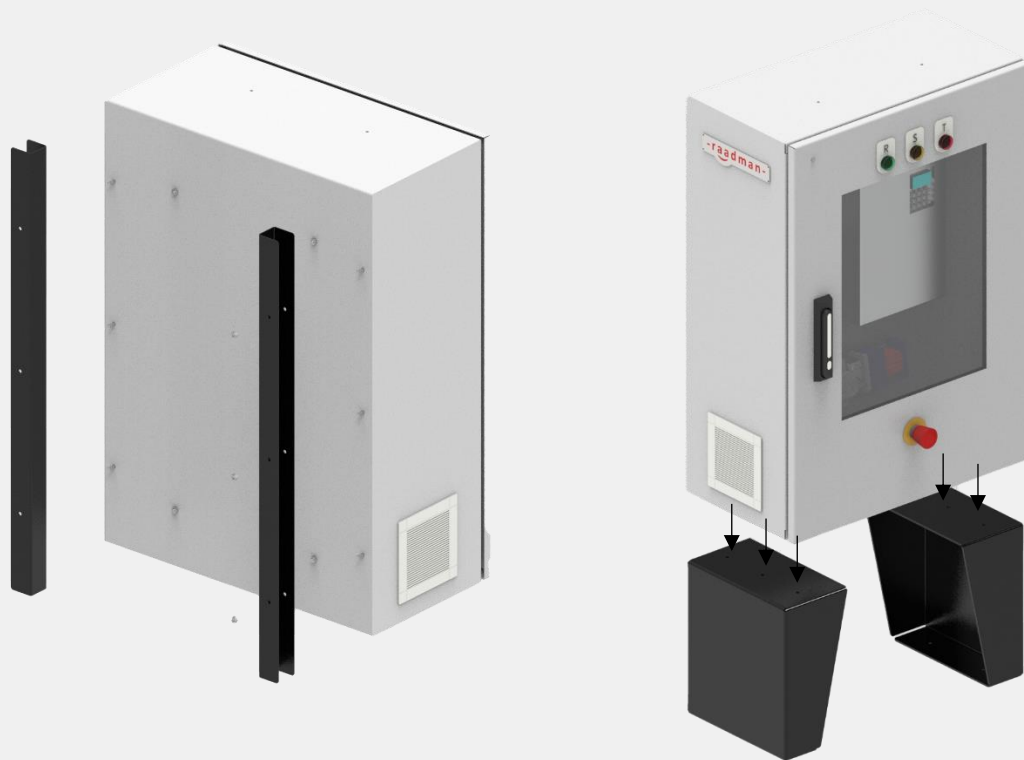

There are two brackets designed to be connected behind the panel which help to install the panel on desired place.

There are two bases to be connected under the panel which can be screwed to the earth. These bases are designed in such a way that electrical wires can be easily connected via glands under the panel.

## RMS series IP

IEC (International Electrotechnical Commission) has published standard 60529 for describing a system to classify the degrees of protection provided by the enclosures of electrical equipment. This system is suitable for using with most types of electrical equipment.

IP Code is a coding system to indicate the degrees of protection provided by an enclosure against access to hazardous parts, ingress of solid objects and water. It also provides detailed information regarding the protection.

radman electrical panels have a high degree of protection (IP 54) due to the following features:

- electrostatic coating that provides high resistance against changes in temperature, humidity, freezing and cold.
- the fan and filter have been selected from among reputable brands that not only exchange the air and cool the panel, but also keep the panel IP at a high level.
- using polyurethane foam between the panel's door and body prevents the ingress of water, steam, and dust to electrical panel.



# VSD wiring diagram

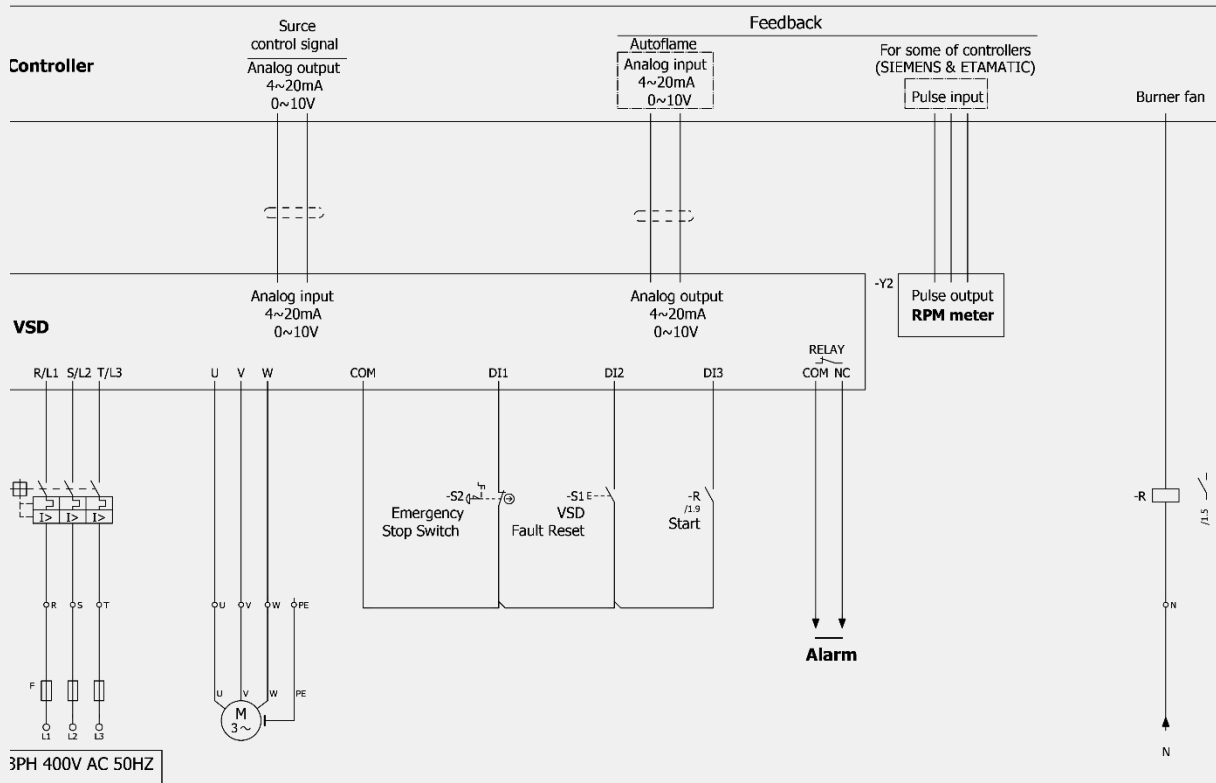

# Star-Delta wiring diagram

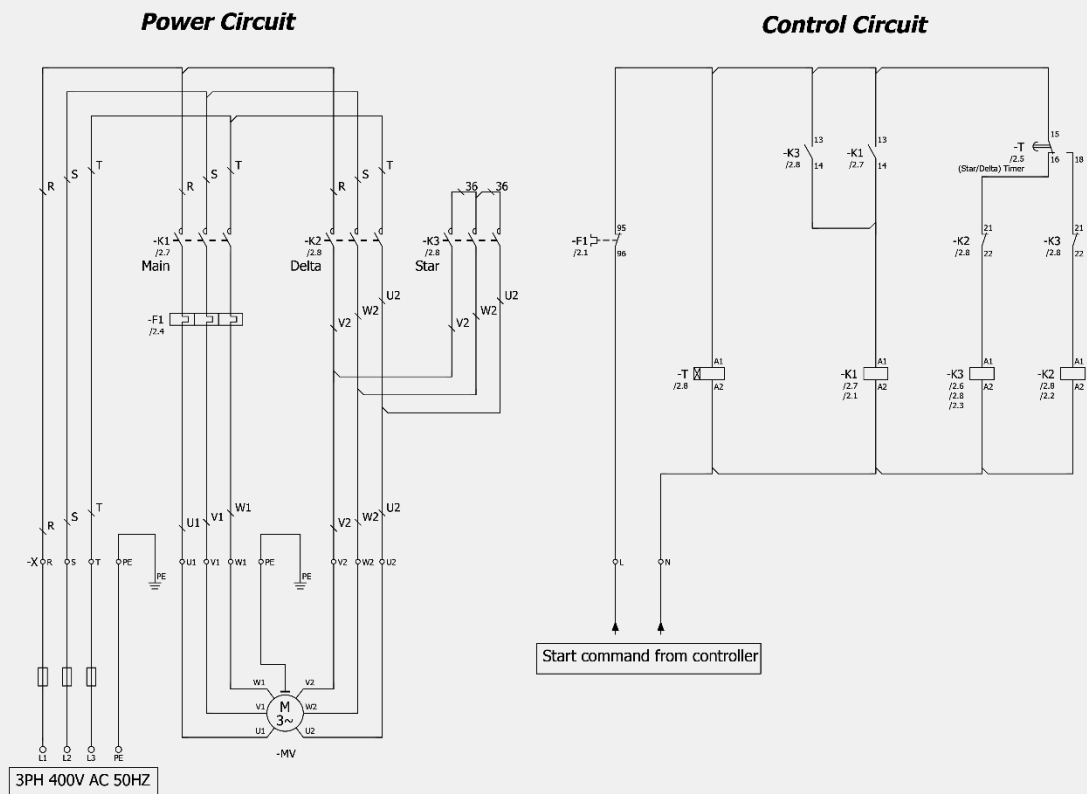





Reliable worldwide packing

- raadman -

**Oil Station**



- SMILE INTO THE FUTURE -

[www.raadmanburner.com](http://www.raadmanburner.com)

## Oil station

The Oil Stations are designed to treat and prepare light oil; they mainly consist of a filter, a pump and a motor.

The Oil Station can independently be prepared, assembled, tested and installed. The wide range of available models makes the system suitable for many different applications.

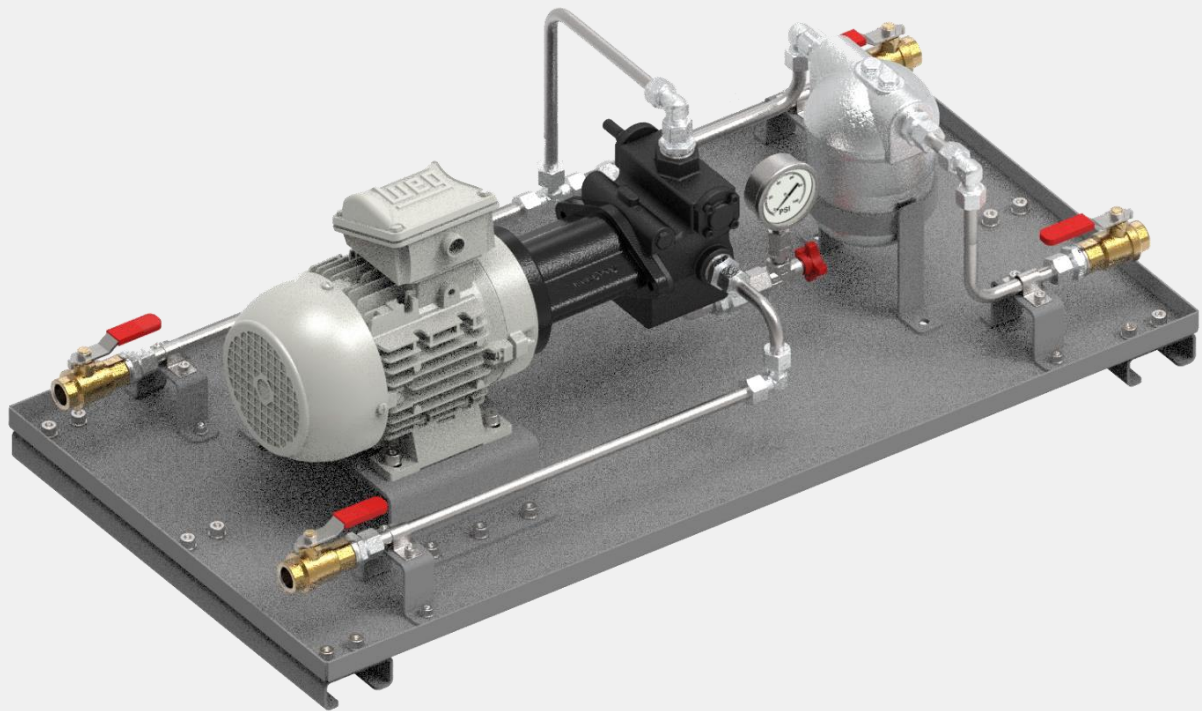



## Heavy oil heater

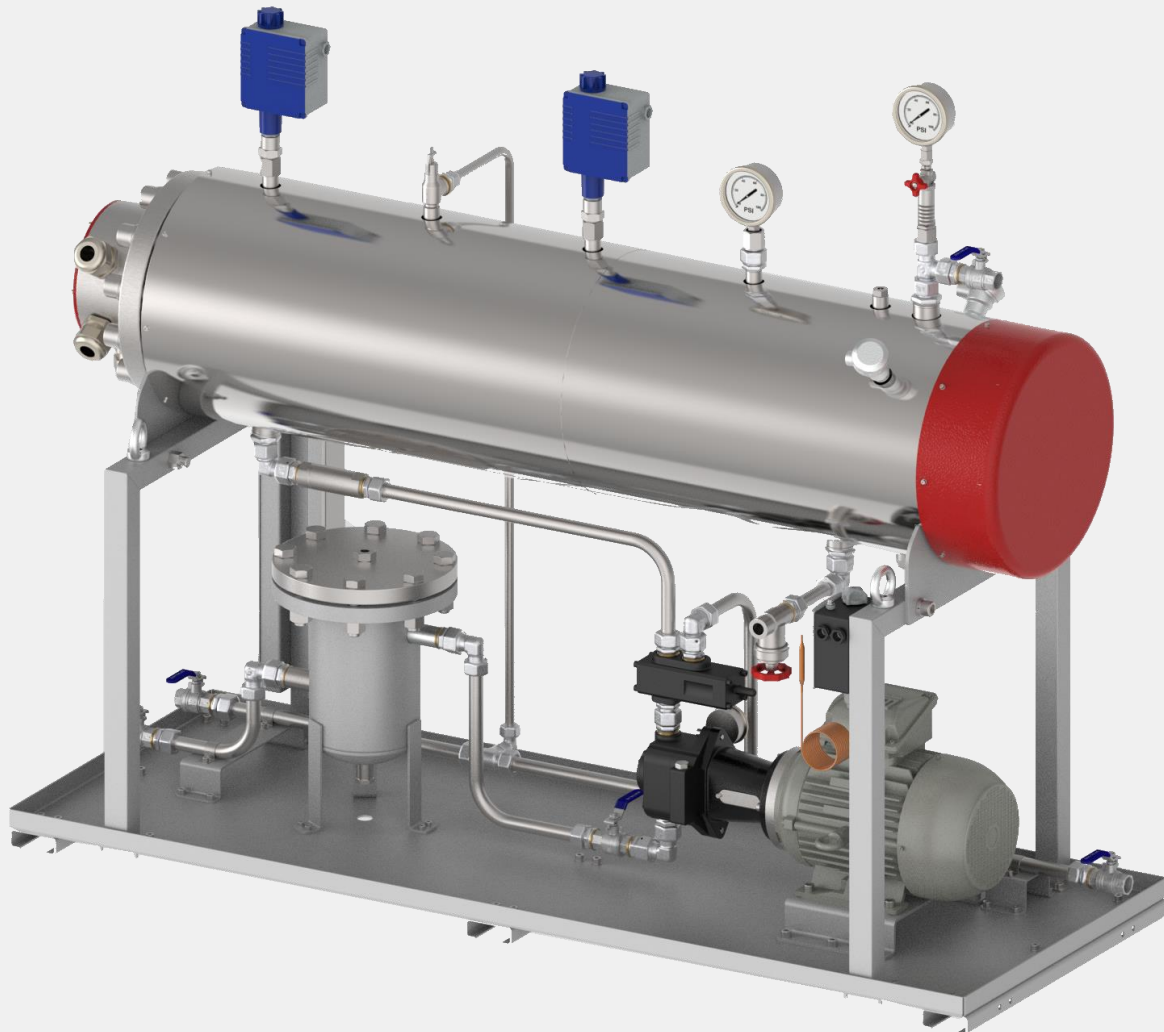

Packman heavy fuel oil preheaters are designed to heat heavy oil efficiently to adjust the proper viscosity for the burner. The design is based on the general conditions such as the type and properties of the heavy fuel oil, pressure requirements of the pump and temperature as well as the desired operating points in the process. Electrical heavy fuel oil heater directly heats fuel by converting electrical energy in the heating elements to thermal energy. The thermal energy is then transferred from the heating electrical elements to the fluid.

The unit skids are designed in order to prepare heavy fuel oil with max viscosity 10 cSt at 130°C and outlet pressure of 25 mbar.

# Heavy Oil Heater

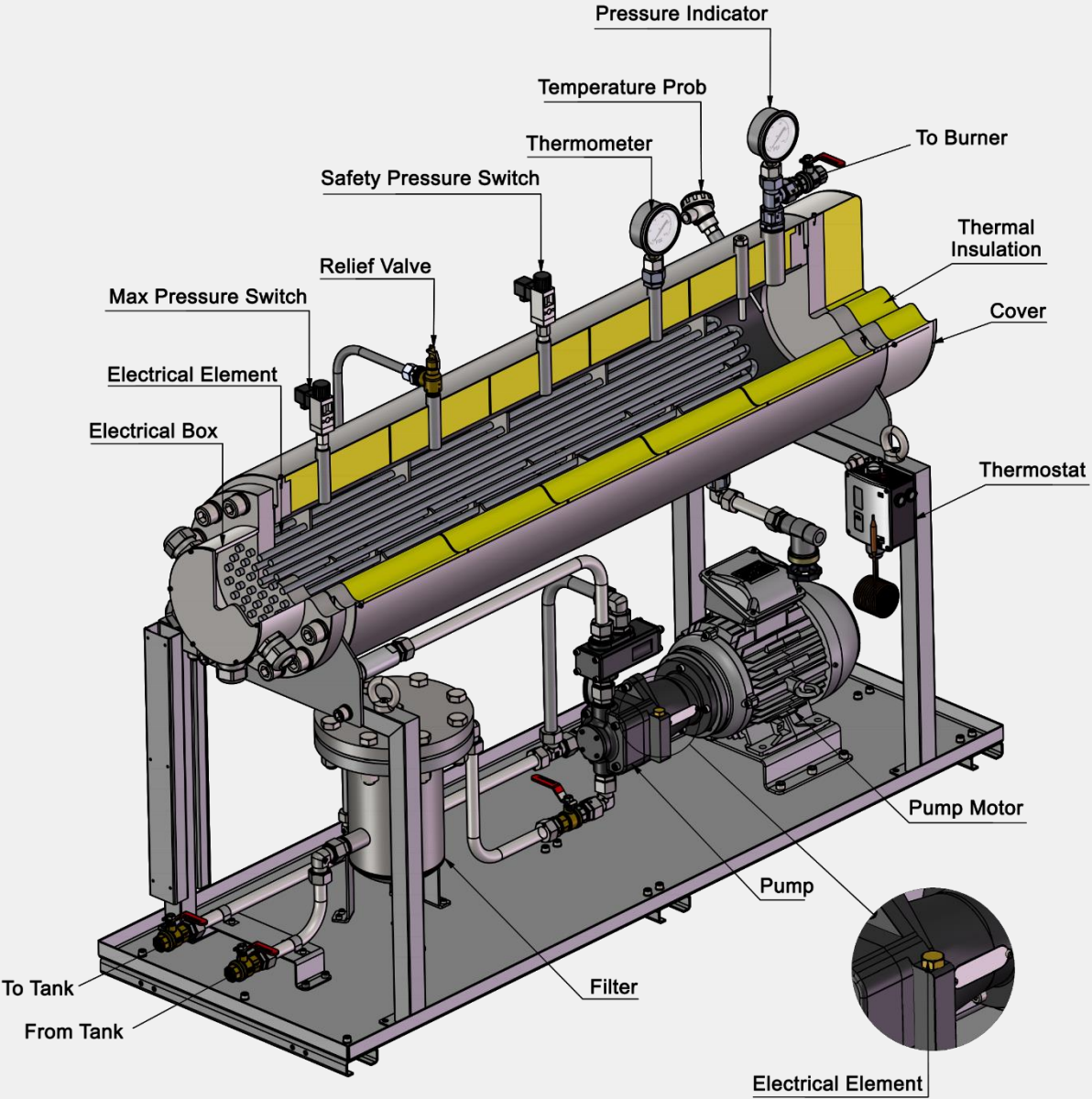

## Oil delivery system

Generally, two types of atomizing principle are utilized in raadman modular oil burners:

### Pressure based spill back lances/atomizers:

All raadman pressure -based atomizing modular oil burners are equipped with a burner lance and a fly-back oil atomizer. The burner-lance is especially suitable for using in or on an oil burner and is designed to operate spill back atomizers with integrated shut-off needle. The strong spring on the actuating rod pushes the needle in closed position. This ensures a reliable shut-off under all circumstances.

Fuel, branched off from the supply line actuates the piston for opening, either controlled by two external solenoid valves or by one 3/2 solenoid valve. The piston has a consistent movement. While opening, the needle inside the atomizer is retracted in the correct position by means of a spring at the back of the atomizer against a fixed stop on the needle itself.

During the pre-purge period of the burner, the needle is keeping the orifice closed and the fuel circulates through the lance at pre-set supply and return pressure. On both energized solenoid valves and the 3/2 solenoid valve, even after long idle intervals, there is an immediate atomization guarantees perfect ignition.

The burner-lance is suitable for supply pressures from 20 up to 40 bar and fuel temperatures up to 140°C.



### Air or steam lances/atomizers

All raadman air/steam atomizing modular oil burners are equipped with a special burner lance and an air/steam atomizer. The burner-lance is designed to operate 32-Y atomizers with compressed air or steam.

The strong spring on the actuating rod pushes the needle in closed position. Compressed air, controlled by an external 3/2 solenoid valve, actuates the piston for opening. The piston has a fixed travel, pulling the needle in the correct position when it opens.

During the pre-purge period of the burner, the needle is keeping the central orifice in the reverse disc closed. On energizing the 3/2 solenoid valve, even after long idle intervals, there is immediate atomization guaranteeing perfect ignition.

The burner-lance is suitable for supplying pressures up to 16 bar and fuel temperatures up to 140°C.





# Staging dual fuel burner

## Two Stages dual-fuel burner

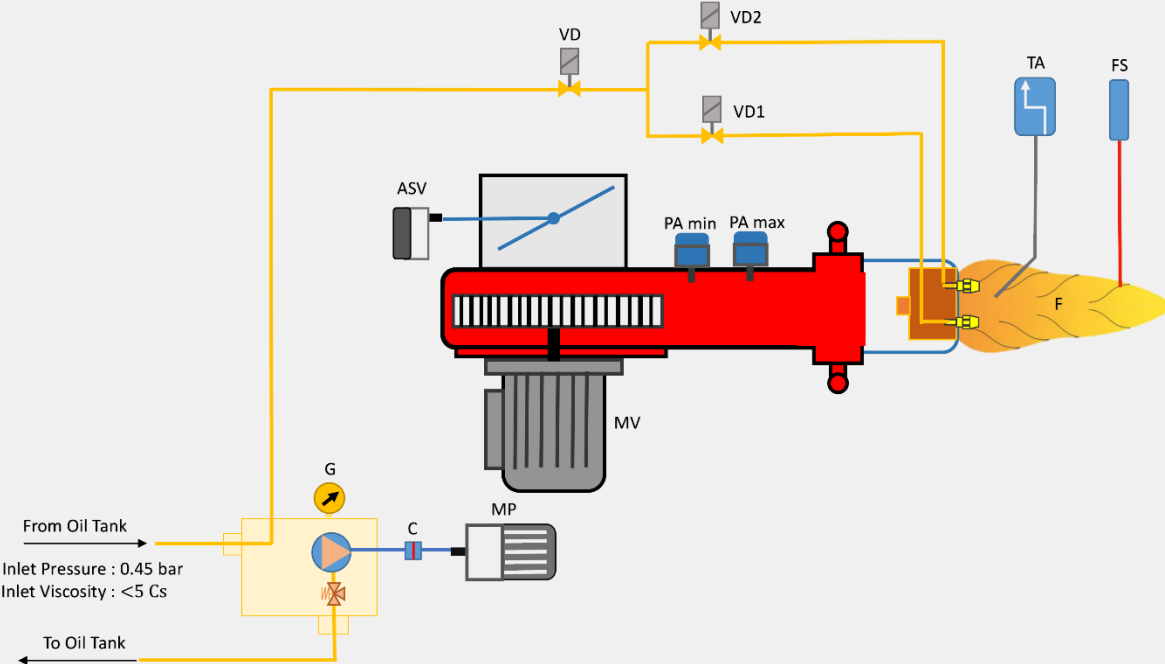

## Three Stages dual-fuel burner

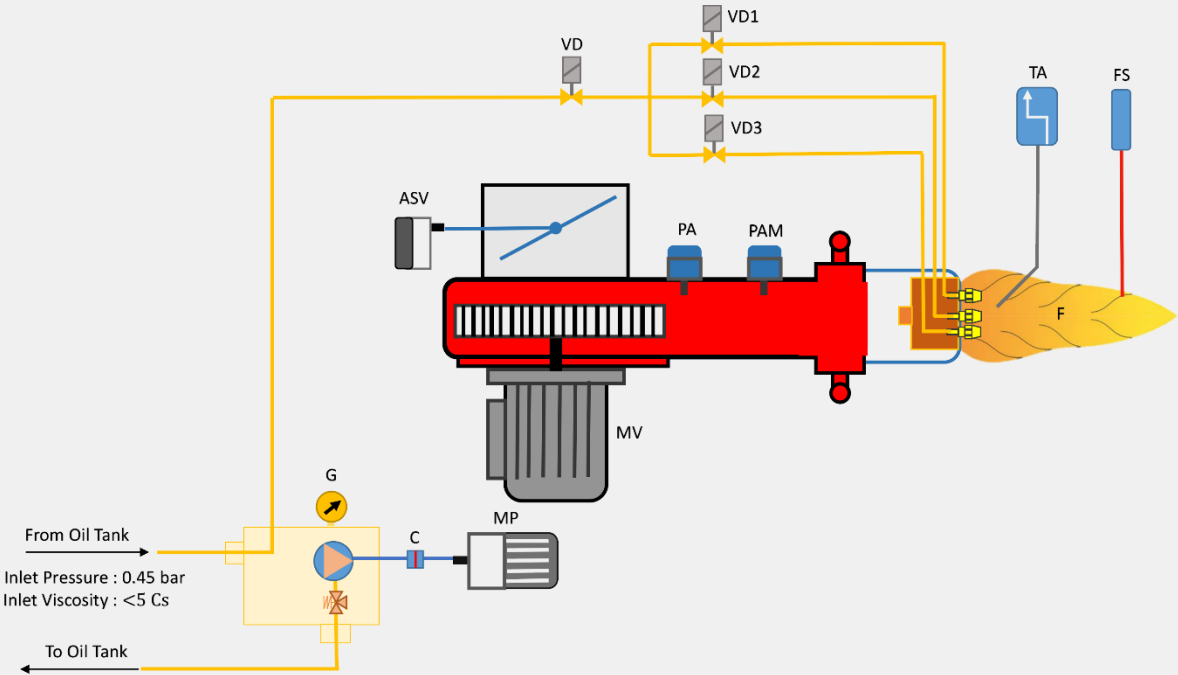

# Modulating dual fuel burner type

Type OL-I: (Pressure based atomizer – without closing needle)

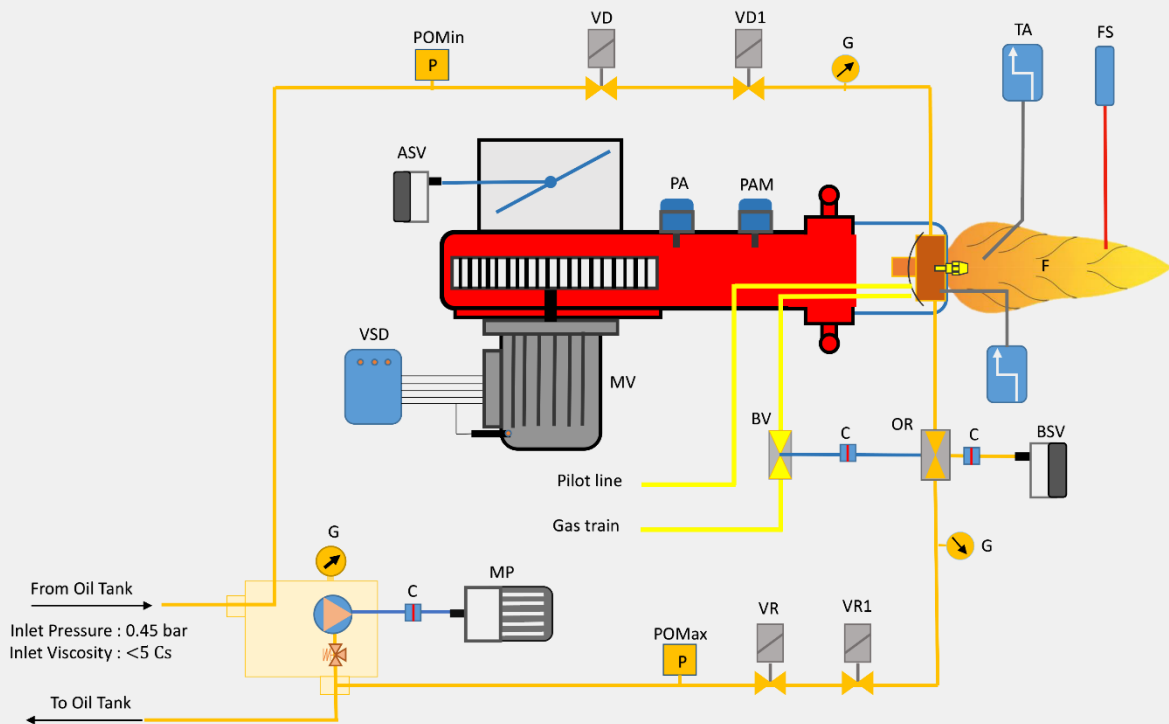

Type OL-II: (Pressure based atomizer with closing needle)

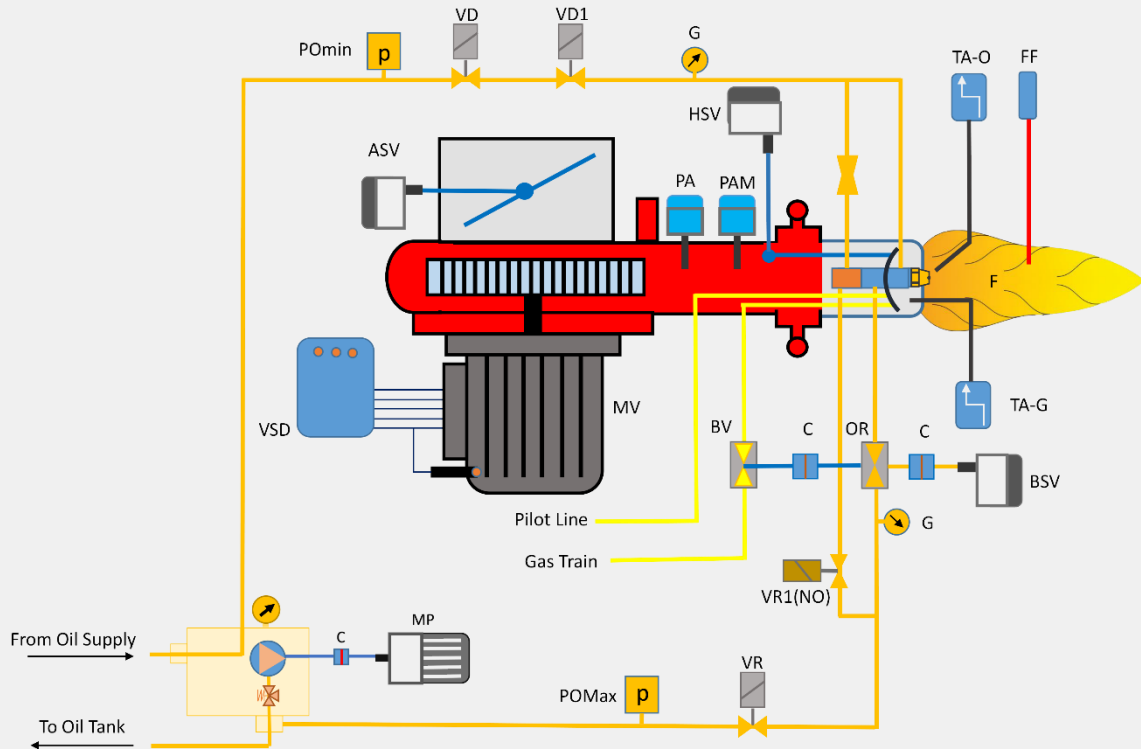

### Type OL-III: (Air/Steam Atomizing technology with closing needle)

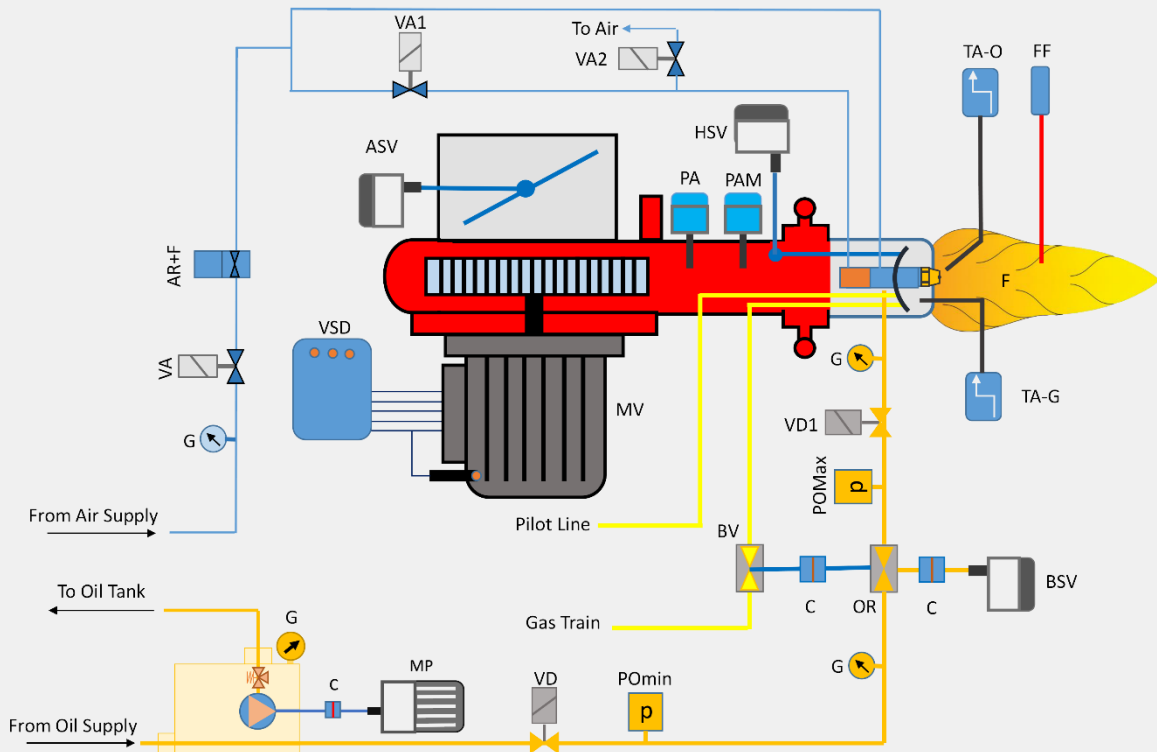

- |                                      |                                |                                     |
|--------------------------------------|--------------------------------|-------------------------------------|
| MP: Pump motor                       | PA: Min. Air pressure switch   | TA-G: Gas ignition transformer      |
| FF: Flame sensor                     | PAM: Max. air pressure switch  | BSV: Butterfly valve servomotor     |
| VR: Return solenoid valve            | POmin: Min. oil pressure       | ASV: Air damper servomotor          |
| VR1: Return solenoid valve           | POmax: Max. oil pressure       | HSV: Head servomotor (Optional)     |
| VR1(NO): Return solenoid valve (N.O) | VA: Air Valve                  | BV: Butterfly valve                 |
| VD: Light oil safety valve (N.C)     | AR+F: Air regulator and filter | OR: Oil Regulator                   |
| VD1: Light oil delivery valve (N.C)  | TA: Flame Scanner              | MV: Fan motor                       |
| VA1: Air solenoid valve1             | FS: Flame Sensor               | VSD: Variable speed drive(optional) |
| VA2: Air solenoid valve2             | F: Gas or oil flame            | C: Coupling                         |
|                                      | TA-O: Oil ignition transformer | G: Gauge                            |



aa

- SMILE INTO THE FUTURE -



**H<sub>2</sub>**

**Clean  
Fuel**

**Renewable  
Energy**

**Low CO<sub>2</sub>  
Emission**



# Research & Development



- SMILE INTO THE FUTURE -

[www.raadmanburner.com](http://www.raadmanburner.com)



## Industrial furnace burner

In the progressive world where we live, the combustion process and industrial furnaces play a significant role. raadman is planning to add industrial furnace burners to its product line soon.

Furnaces are used in industries such as:

- Metal melting
- Preheating units, for instance, annealing
- Minerals production like glass, cement, bricks, refractory materials, and ceramics
- Petrochemical and refinery industries
- Waste incineration industries
- Drying processes such as paper production, printing, and publishing
- Food industries, like beverage

Furnace load and operating temperature specify the type and the number of burners that should be installed on the furnace.

According to furnace operations, burners can install vertically or horizontally on furnaces.

Furnace burners are categorized into direct or indirect flame, high-velocity, flameless, oxygen-enriched, regenerative, and recuperative.

The NO<sub>x</sub> generated in this type of burner is very low due to the intense mixing of the reactants and the very uniform flame temperature distribution.

### Flameless burners

Flameless, mild, or HiTAC combustion is a process that the flame is not visible with the naked eye. As an advantage of this method, we can point out that NO<sub>x</sub> and CO emissions are extremely low because of high reactant mixing and homogeneous low flame temperature. Achieving flameless combustion can occur using oxygen dilution (MILD), combustion air preheating (HiTAC), and colorless distributed combustion (CDC) methods.

### Oxygen enriched burners

A way to increase combustion temperature is using Oxygen Enhanced Combustion (OEC). In this method, pure oxygen has injected directly into the burner or furnace. Oxygen-enriched burners can work with both air-oxygen mixture and pure oxygen. In industries, these burners are known as air-oxy fuel and oxyfuel burners, respectively. It should be noted that flame temperature and NO<sub>x</sub> formation in air-oxy fuel burners arises. Unlike air-oxy fuel burners, oxyfuel NO<sub>x</sub> emission is nearly zero due to the absence of nitrogen on the reactant side.

### Direct or indirect flame burners

The furnace industry and products determine the type of flame contact. In many heats' treatment processes, where the combustion gases must not come into contact with the products, indirect flame burners are used. Radiant tubes connect to the burner, and the flame will propagate through them, so the radiation mechanism transfer heat to the products. Unlike indirect flame, combustion gases are in contact with products in direct flame burners.

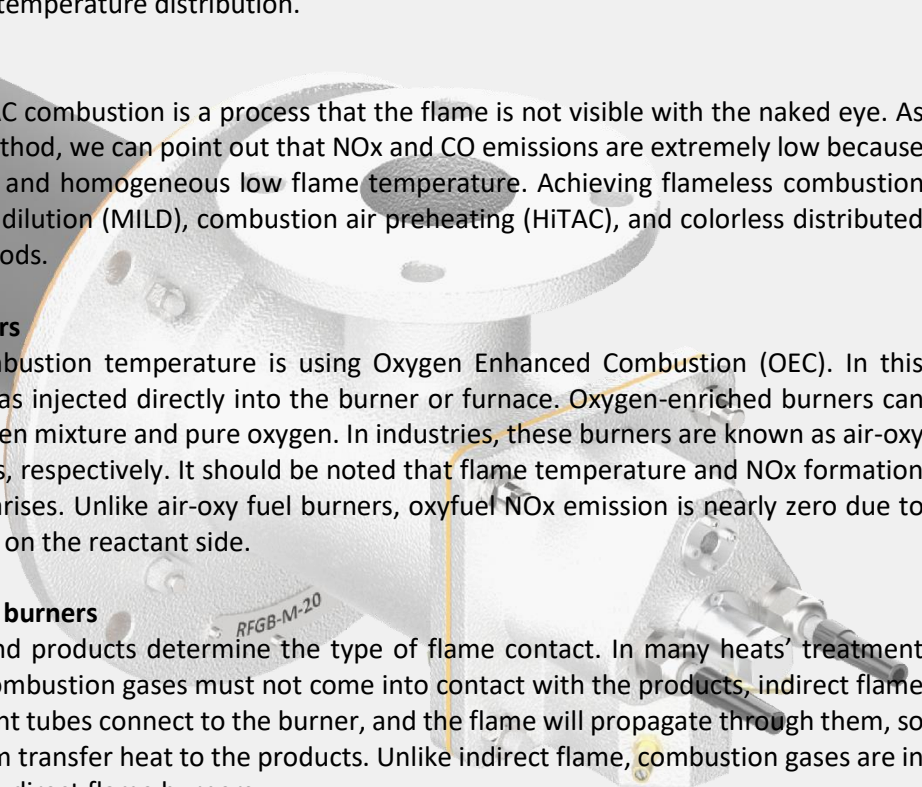

## What is hydrogen combustion?

In today's progressive world, air pollution and greenhouse gas emissions are the most common problems in urban areas. Domestic and industrial burners significantly contribute to the production of pollution like CO and NOx. Hydrogen has genuinely great potential benefit to sustainably supply green energy to industrial areas where decarbonization is a complicated procedure. Hydrogen covers a wide range of flammability limits in air, so it is highly reactive. Hydrogen-free carbon combustion produces only water and has no unburnt (unburned) hydrocarbons (UHCs), and doesn't emit carbon dioxide (CO<sub>2</sub>). Because of the higher flame temperature and high combustion rate, NOx formation in hydrogen combustion is more in comparison with hydrocarbons like natural gas or diesel. Hydrogen combustion doesn't generate any soot. Engineers have been researching Hydrogen technologies recently to reduce the reaction rate and NOx formation and prevent the flame flashback phenomenon.

The low heating value of hydrogen fuel is about 2.5 times of natural gas. In the same burner firing rate of 7.5 MW that works 24/7, carbon dioxide emissions are reduced by 35 tons per day. Based on the stoichiometric equations in the state without excess air, the air required for combustion in hydrogen fuel is about 30% less than the air required for combustion with natural gas. It directly affects power consumption. Natural gas and hydrogen blending not only improves combustion efficiency but also reduces carbon monoxide and carbon dioxide emissions. Natural gas has a low heating value than natural gas/hydrogen fuel, reducing fuel consumption.

Consequently, a hydrogen burner, for either home heating or industrial applications, can be a master key toward a greener planet and preserve sustainability in the energy field. However, the techniques of hydrogen extraction or reservation are still a challenge. As cutting-edge technology, it needs too much support and superior cooperation between scientists, environmental activists, social leaders, and producers.

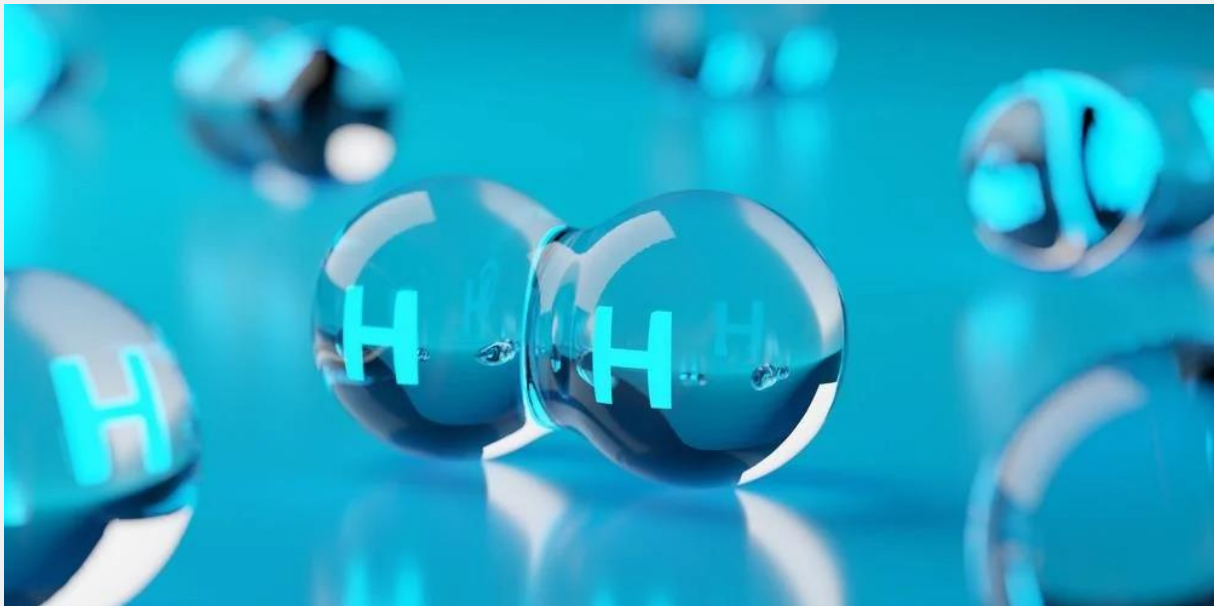

### Hydrogen as a clean fuel

Combustion systems such as internal combustion engines, burners, gas turbines, etc., that use fossil fuels emit carbon dioxide. As a result, climate change and global warming happen. Decarbonization as a clean industrial solution is a fundamental method that enhances our production processes to reach a better environment. Fuel replacement is one of the ways to overcome this issue.

Hydrogen has great potential in decarbonizing transportation, industrial, commercial and residential sectors. The capability of hydrogen that can be generated through different renewable energy sources makes it an integral part of a renewable energy system. This way allows engineers to substitute natural gas pipelines with hydrogen to reduce carbon emissions and dependence on fossil fuels.



### Our Place

Today, studies on hydrogen burners have achieved a mixture of about 20% of hydrogen and 80% of natural gas in the forced draught, Nozzle mixed, pre-mixed, and post-mixed burners. The flashback phenomenon may occur in higher combustion ratios.

Toward the edge of technology in combustion science, research is being carried out in our R&D department to create reliable combustion of pure hydrogen fuel without the problem of flashback. As a result, we are proud that our high technology-hydrogen-ready burners are working well, with the lowest amount of emission according to international standards.





## Research and development department

The research and development department of raadman company was established with the particular purpose of technologically supplying all the company's departments and keeping pace with the latest global developments and improvements in the field of combustion. Interpretation and analysis of the obtained information, examination of opportunities and threats, and knowledge of strengths and weaknesses will facilitate the policy-making process. The impressive achievement of this process is the development, determination, and direction of a long-term road map to adapt to emerging technologies and international policies in the field of combustion emissions.

Nowadays, the activities and achievements of our department are as follows:

- The R&D department of raadman company, using the knowledge and experience of combustion engineers and specialists and re-engineering, has successfully developed and diversified products.
- Optimizing produced burners, improving the consumption pattern, increasing the lifetime of equipment, reducing waste products, providing intelligent solutions to reduce production costs, reducing combustion emissions, finally satisfying customers and improving the quality, and so on,
- The R&D department of raadman company has regulations related to activities which have the dissemination of knowledge, including holding training courses on the topics of familiarization with the latest technologies in the field of combustion, burner control systems, and combustion simulations, as well as supporting the publication of books, presenting scientific articles in national and International conferences, providing support for holding national combustion conferences as well as research activities such as master and Ph.D. theses The design of the combustion laboratory has been done for practical and theoretical training of customers and the optimal use of produced burners.
- Activities are underway to collect, share and protect the knowledge and experience of engineers throughout their working life and to create a cycle of information exchange between people with different specializations and work areas.

Improving the functional conditions of the burners in the first step is based on the complete study of the combustion process and fluid and structural analysis. Next, the prototype is made and, in the combustion laboratory, will be tested, and after the final optimizations, it will reach mass production.

Simulating the combustion process with the help of computational fluid dynamics and combustion models is very important to understand combustion reactions, heat transfer, temperature distribution, flame dimensions, energy losses, and flow pressure drop passing through the burner and boiler or furnace. The research and development department has investigated the functions of burners production using various models of premixed, partial premixed, post-mixed, flameless combustion, liquid fuel combustion, and considering fuel phase changes. It also uses up-to-date knowledge to design and optimize the fan used in the air supply system of the burners and the thermal stresses applied to the components of the burner combustion head.

As the most highlighted, you are invited to take a look at our major duties in the R & D department of raadman Burner Company:

- **Combustion analysis, simulation of the specific flame shape, pollution calculation:**

Combustion analysis is needed to check the flame's dimensions and optimize the flame's shape according to the dimensions of the boiler or furnace. If the temperature is evenly distributed, there will be no problems, such as damage to the combustion chamber due to the creation of high-temperature points in the direction of the flame hitting it. The creation of high-temperature points in the boiler causes blockage of the water path due to the formation of hard crystals of water-soluble salts in these points. Also, the load of the furnace needs to receive a homogeneous temperature at all points.

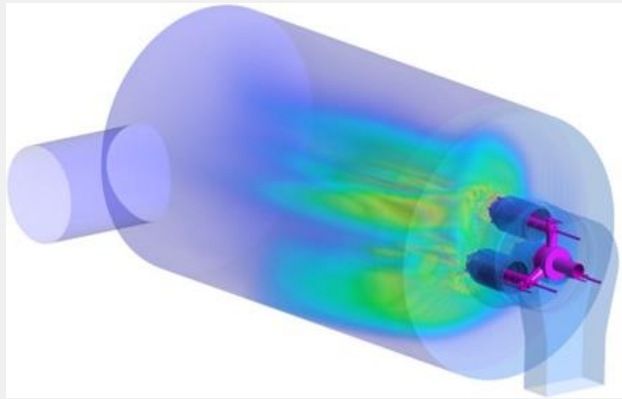

- **Flame stability considerations:**

It will be possible to achieve a stable flame by creating a proper distribution of air and fuel at different stages of the burner combustion head. Preventing the formation of hotspots in the flame root leads to the minimizing emissions. It prevents the formation of hotspots achieved by installing and optimizing different diffusers, swirl flows, and variable flame covers.

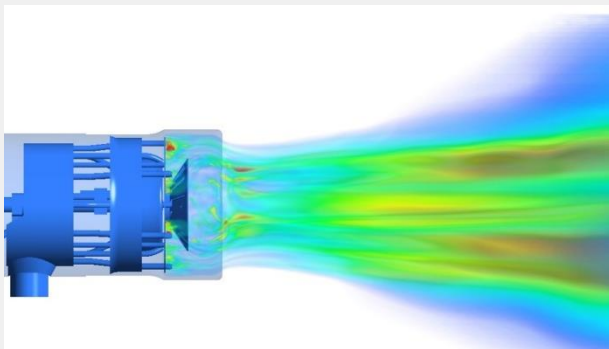

- **Atomizing analysis**

In liquid fuel, due to the low octane number, the combustion process is not easily performed as a measurement for fuel quality. Therefore, it is necessary to break up the liquid fuel into fine particles to improve oil vaporization. The fuel oil vapor mixes with the combustion air, and combustion occurs. Atomizing liquid fuel is a process in which a fluid volume is converted into small droplets with the help of an external force.

Mixing fuel thoroughly in the vapor state and air is necessary to complete the combustion. The liquid fuel mass has a small contact surface with the airflow. Atomization

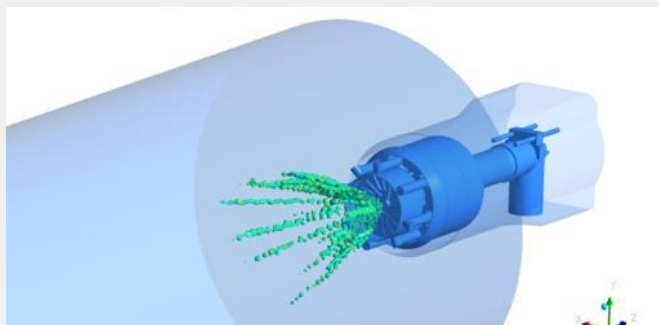

increases the contact surface of the fuel in the liquid state with the combustion air. Therefore, the fuel evaporation rate will increase, and as a result, the fuel and air mixing rate will also increase. If the atomization is incomplete and the size of the droplets is not small enough, the particles cannot be ignited entirely, and sometimes they are seen as throwing fire particles into the flame. Incomplete atomization of particles causes incomplete smoky combustion, lower efficiency, and formation of deposits in the combustion chamber. With the help of the Discrete Phase Method (DPM), modeling of

atomizers, and solving the flow and temperature field, it is possible to simulate the combustion of various types of liquid fuel and avoid the abovementioned problem.

- **High-temperature zone for material selection:**

Lack of proper mixing of fuel and air in the burner and combustion chamber will produce high-temperature or low-temperature areas. High temperature accelerates the formation of nitrogen oxides. The creation of points with low temperatures will decrease the combustion rate, which will cause carbon monoxide not to react with the oxygen in the combustion chamber, and carbon monoxide, as a harmful pollutant, will be released into the environment from the chimney. Combustion simulation in the burner can determine the continuous temperature distribution in the device in the combustion heads of the burner. Having the temperature distribution data allows suitable material selection and prevents the creation of thermal stresses.

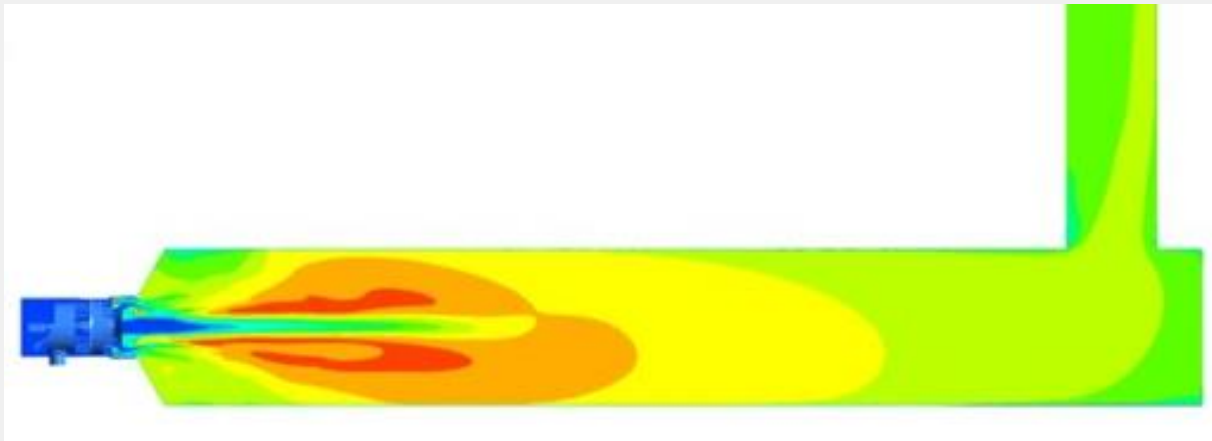

- **Ventilation system (Air bloc) simulation**

Fluid-Solid Interaction (FSI) in centrifugal fans makes it possible to determine the appropriate blade profile and thickness. Proper blade profile choice and dimensions optimization increase efficiency and reduce energy consumption and production costs. We can also use the acoustic analysis of the fan to reduce noise pollution.



- **Heavy fuel oil temperature/viscosity analysis**

The oil burner is one of the burners used in cases that require a large volume of hot water and hot steam, such as refineries and powerhouses, to provide heat for boilers and furnaces. For proper spraying and combustion of fuel oil, it is necessary to reduce its viscosity sufficiently. Viscosity can be decreased by increasing fluid temperature using electrical heat exchangers or steam exchangers to increase fuel temperature. Simulation, design and calculations related to this type of heat exchanger are one of the tasks in the research and development department.

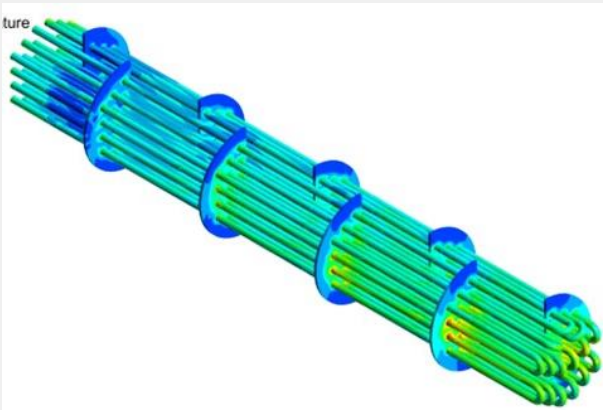

- **Staging combustion:**

NOx emission is one of the fundamental problems of combustion-related industries, including power plants, petrochemicals, and refineries. Using staged combustion of fuel or air is a way to reduce NOx production in water tube burners. In this method, by creating a fuel-rich or fuel-lean area, NOx production can be reduced by 50% compared to conventional burners.

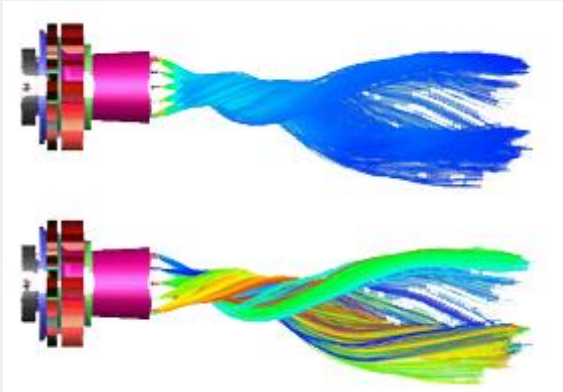





RGB M-1250



# Flame dimension

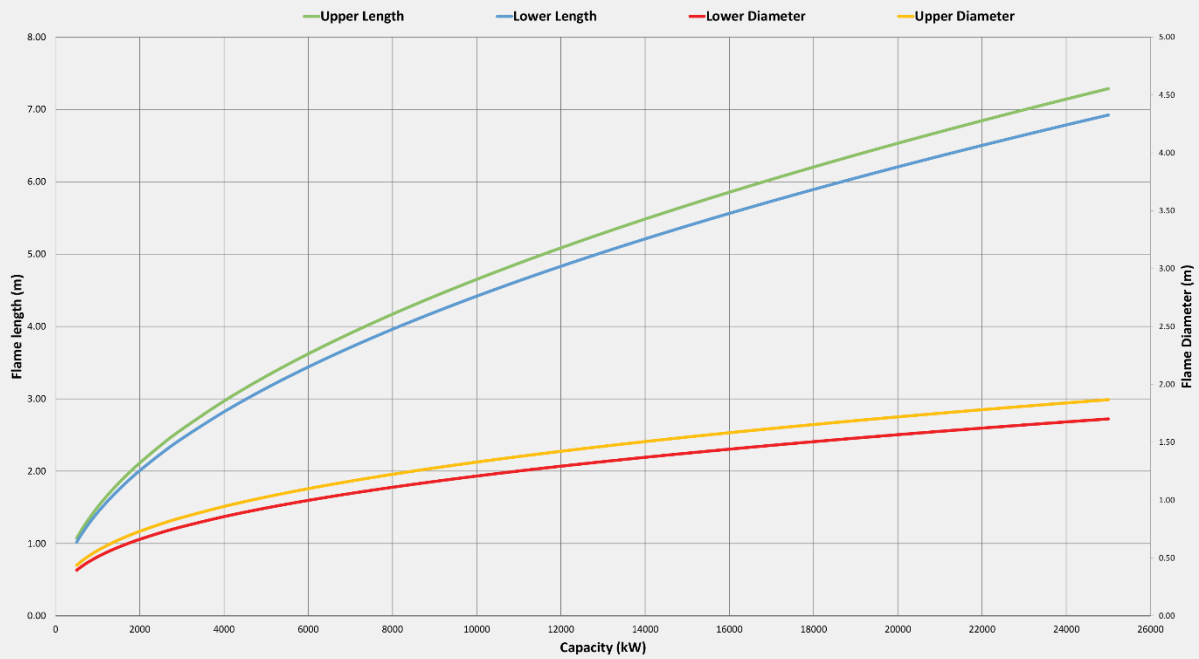

Note: Due to the possibility of changes in the flame dimensions because of variable geometry of combustion heads in the burners, the length and diameter of the burner flame are considered within a range of  $\pm 5\%$ .

The flame dimensions which play an effective role in the burner efficiency and influence their compatibility to the boiler combustion chamber geometry, are presented in the above diagram.

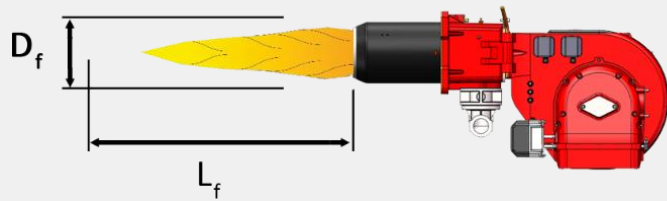

## Suggested combustion chamber dimension:

The raadman burners can be appropriately selected for all boilers which are according to the BS-2790, BS-855, EN-303, BS-EN 12953-3.

It is recommended that a flame fill 90% of combustion chambers at its maximum output.

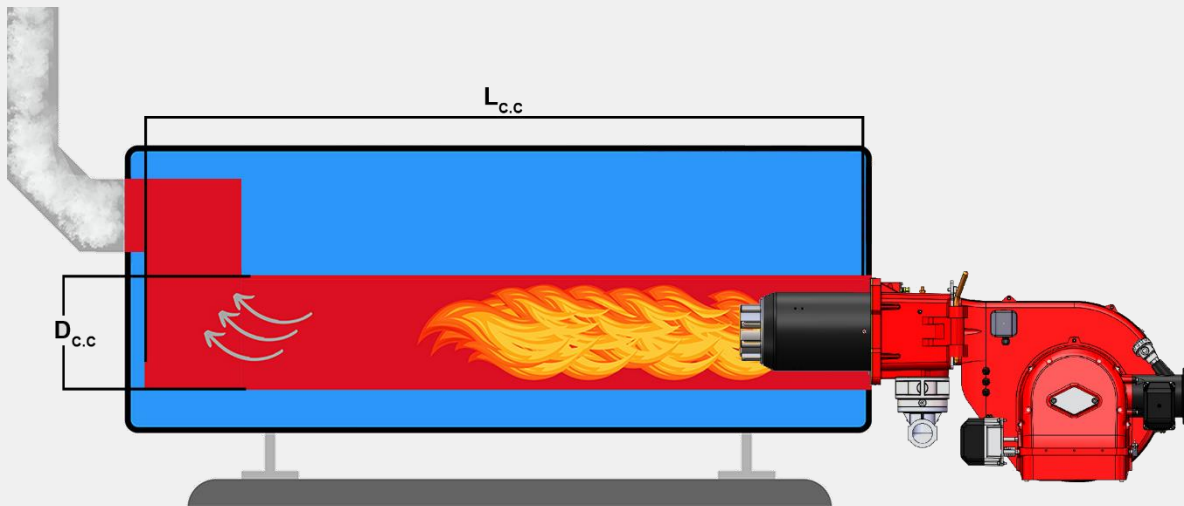



## A look to the future:

### With Low-NO<sub>x</sub> burners

NO<sub>x</sub> gases play an important role in the formation of smog, producing the brown haze often observed over cities, particularly during the summer. When exposed to the UV rays in sunlight, NO<sub>x</sub> molecules break apart and form ozone (O<sub>3</sub>). The problem is made worse by the presence in the atmosphere of volatile organic compounds (VOC), which also interact with NO<sub>x</sub> to form dangerous molecules. Ozone at the ground level is a serious pollutant, unlike the protective ozone layer much higher up in the stratosphere.

Nitrogen oxides form when oxygen and nitrogen from the air interact during a high-temperature combustion event. Heating industry and industrial burners, in particular, produce large amounts of nitrogen oxides.

The idea of Low NO<sub>x</sub> burners is to control fuel and air mixing at each burner in order to create larger and more branched flames. Peak flame temperature is thereby reduced, and results in less NO<sub>x</sub> formation. The improved flame structure also reduces the amount of oxygen available in the hottest part of the flame thus improving burner efficiency.

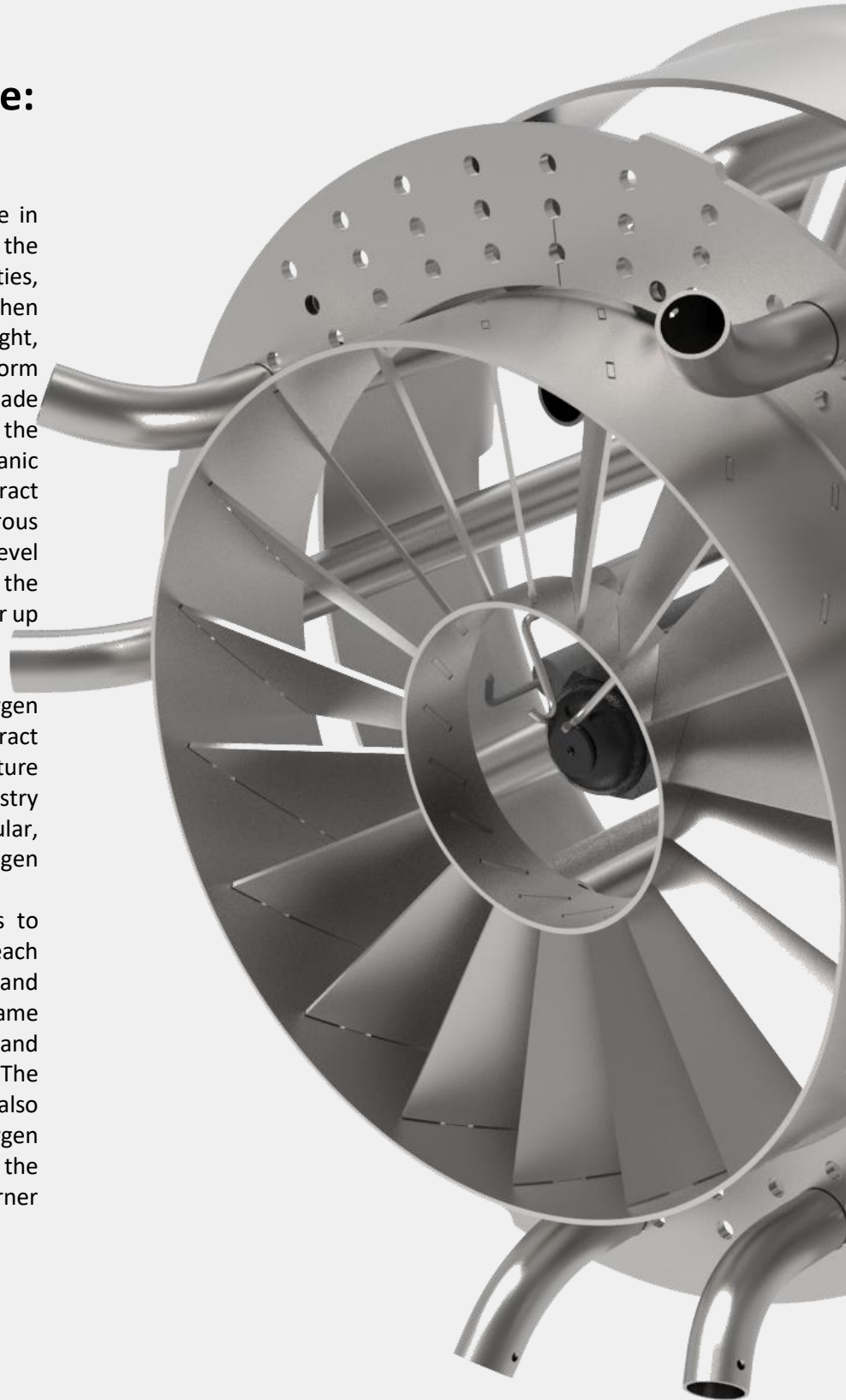

## FGR technology

Flue gas recirculation (FGR) can be a highly effective technique for lowering NO<sub>x</sub> emissions from burners, and it's relatively inexpensive to apply. Most of the early FGR work was done on boilers, and investigators found that recirculating up to 25% of the flue gases through the burner could lower NO<sub>x</sub> emissions to as little as 25% of their normal levels.

With FGR technology, consisting of a temperature sensor and flue gas damper with an actuator connected to a flange, a portion of the exhaust (flue) gas circulates back into the combustion zone to decrease the flame temperature and reduce the flame nitrogen-oxide (NO<sub>x</sub>).

When FGR is used, because of reduction in radiation heat transfer, boiler efficiency may decrease typically in the range of 0.25 percent to 1 percent, depending on the amount of FGR added. Plant experience shows that the combination of low NO<sub>x</sub> burners with re-burning using FGR system reduces the NO<sub>x</sub> level to approximately lower than 40 mg/kWh

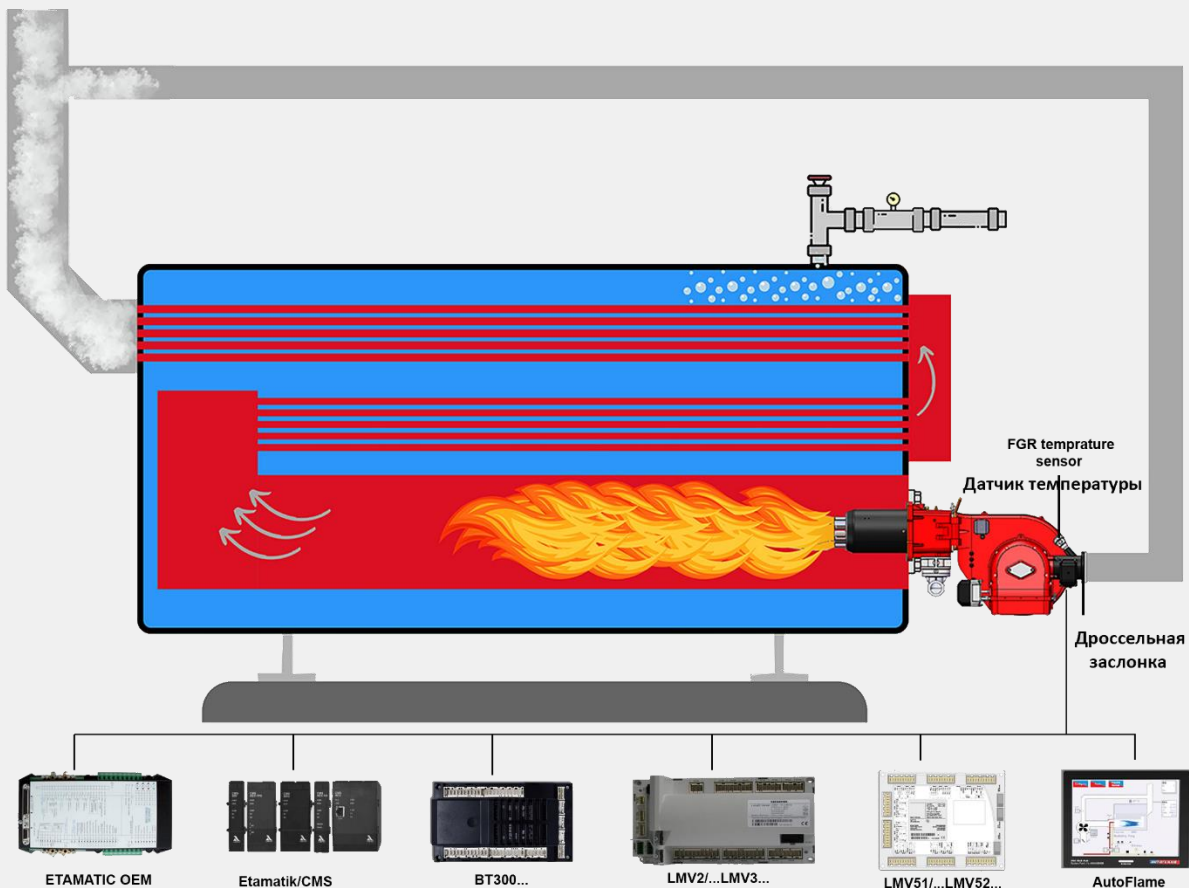
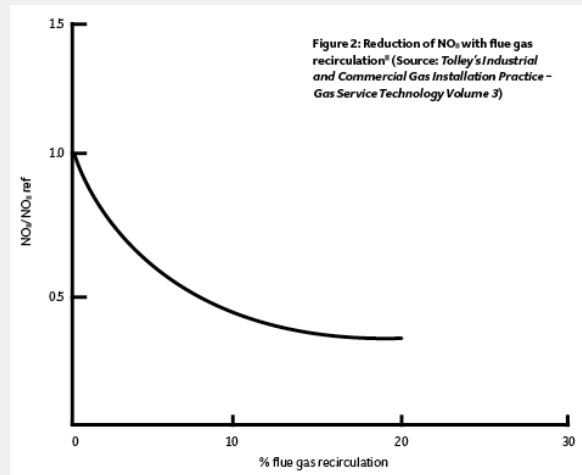



- raadman -



Training- raadman Burner Factory





**Let's do our best to save our planet for a more comfortable life for the next generation.**

# Burner selection request

Full Name:	Company:
Email:	Phone Number:

## Project Information

Project Type	Powerplant	<input type="checkbox"/>	Industrial	<input type="checkbox"/>	Domestic	<input type="checkbox"/>	Others	<input type="checkbox"/>
--------------	------------	--------------------------	------------	--------------------------	----------	--------------------------	--------	--------------------------

## Boiler and Burner Information

Boiler Type	Steam	<input type="checkbox"/>	Hot Water	<input type="checkbox"/>	Hot Oil	<input type="checkbox"/>
	Water Tube	<input type="checkbox"/>	Condensing	<input type="checkbox"/>	Fire Heater	<input type="checkbox"/>
	Process Furnace	<input type="checkbox"/>	Others	<input type="checkbox"/>		

Number of Furnaces or Burners	Single	<input type="checkbox"/>	Dual	<input type="checkbox"/>	Multi, NO:.....	<input type="checkbox"/>
-------------------------------	--------	--------------------------	------	--------------------------	-----------------	--------------------------

Boiler or Furnace Capacity ..... kcal/hr

Required Burner Firing Rate (Optional) (Considering boiler efficiency and installation altitude) ..... KW

Burner pollution class (Natural Gas)	NOx Class 1: less than 170 mg/kWh	<input type="checkbox"/>
	NOx Class 2: less than 120 mg/kWh	<input type="checkbox"/>
	NOx Class 3: less than 80 mg/kWh	<input type="checkbox"/>

## Burner Configuration

Burner Configuration (Optional)	Mono Block Configuration	<input type="checkbox"/>
	Dual Block Configuration	<input type="checkbox"/>
	Premixed Burners (PE Series, PM Series)	<input type="checkbox"/>

## Burner Operation

Burner Operation (Optional)	Electronic Modular (continuous electronic operation from low to high firing rate)	<input type="checkbox"/>
	Mechanical Modular (continuous mechanical operation from low to high firing rate)	<input type="checkbox"/>
	Mechanical Staging (discrete operation in one, two, or three stages from low to high firing rate)	<input type="checkbox"/>
	Staging (discrete operation in one, two, or three stages from low to high firing rate)	<input type="checkbox"/>

## Gas Train Information

Fuel	Natural Gas	<input type="checkbox"/>
	LPG	<input type="checkbox"/>
	Light Fuel Oil	<input type="checkbox"/>
	Heavy Fuel Oil	<input type="checkbox"/>

Gas Train Pressure (Optional) .....

Entrance gas line size (in the boiler room) (Optional) .....



## Contact us



### Central Office

Central Office: 4th floor, No2, 10th St, Ahmad Ghasir Ave, Tehran, Iran

Phone: (+98) 021042362

Fax: (+98) 02188737131

[www.packmangroup.com](http://www.packmangroup.com)



### Burner Factory

No. 5, 102 Ave. Montazeriye Industrial Town, Vilashahr, Isfahan, Iran

Phone: (+9831) 42290483

[www.raadmanburner.com](http://www.raadmanburner.com)

#### Information center

Mobile Phone (Telegram & Whatsapp): (+98) 913 429 4984

Email: [info@raadmanburner.com](mailto:info@raadmanburner.com)

#### International sales

Mobile Phone (Telegram & Whatsapp): (+98) 913 429 4965

Email: [Sales@raadmanburner.com](mailto:Sales@raadmanburner.com)

#### Support center

Mobile Phone (Telegram & Whatsapp): (+98) 913 429 4981

Email: [support@raadmanburner.com](mailto:support@raadmanburner.com)



### Isfahan Factory (Hot Water Boiler, Steam Boiler, Chiller, ...)

Packman St, Basij Ave, Imam Khomeini Blvd, Isfahan, Iran

Phone: (+98) 03133686180-2



### Parand Factory (Water Treatment Equipment, Pressure Vessels, ...)

1th Noavaran St, Parand Industrial Town, Tehran, Iran

Phone: (+98) 02157423000





# Registration Certificate

*This is to certify that the*

**QUALITY MANAGEMENT SYSTEM**

*of*

**Packman Co.**

**Head Office:** 4th Floor, No. 2, 10th St., Bokharest Ave., Tehran-Iran

**1<sup>st</sup> Manufacturing Site :** Packman St., Khomeinishahr, Esfahan-Iran

**2<sup>nd</sup> Manufacturing Site:** Montazeryeh Industrial Zone, Vilashahr, Esfahan-Iran

*for*

**Design, manufacturing, installation and after sales services of steam and hot water boilers as well as other relevant products including water softeners, sand filters, deaerators, heat exchangers, industrial gas & oil burners, condensing boilers, water desalination systems and CO2 dosing packages**

*has been assessed and registered against the provisions of*

**ISO 9001:2015**

Registration Number: **1810715**

NACE Code: **DJ28.51 & L74.30**

Assessment Date: **30 August, 2022**

Exclusion: **None**

Date of Registration: **31 August, 2022**

Date of Expiry: **14 Feb., 2024**

Chief Executive Officer  
Concord Certification Corporation



Although this certificate has an expiry date on it, this is pertinent to mention that the three years validity of certificate is subject to on time performing of surveillance visits. Should surveillance audits not take place when required, registration shall be removed. This certificate is the property of Concord Certification Corp. and must be returned upon request.



جمهوری اسلامی ایران  
ریاست جمهوری  
سازمان ملی استاندارد ایران

شماره پروانه: ۶۳۷۴۹۱۴۱۷۵  
تاریخ صدور اولیه: ۱۳۹۷/۱۲/۰۵  
تاریخ تجدید: ۱۴۰۰/۱۲/۰۵



## پروانه کاربرد علامت استاندارد اجباری

براساس قانون تقویت و توسعه نظام استاندارد، مصوب سال یک هزار و سیصد و نود و شش و در اجرای مصوبت شورای عالی استاندارد؛ به موجب این پروانه اجازه داده می‌شود: شرکت ماسیساتی ساختمانی پاکمن (سهامی خاص) با رعایت قوانین و مقررات مربوطه و استاندارد ملی شماره ۷۵۹۵ از علامت استاندارد ایران برای محصول: مثلثی گازسوز با توان ۷۰ تا ۱۲۰ کیلووات و مثلث گازسوز با توان بیشتر از ۱۲۰ کیلووات با نام یا علامت تجاری ثبت شده به شماره ۲۹۵۴۴۲ مورخ ۱۳۹۶/۱۲/۱۴ (پاکمن PACKMAN) استفاده نماید.

محمد فرمانی  
رئیس سازمان ملی استاندارد ایران  
هدی اسلام‌ناه  
محمود فرمانی

واحد تولیدی یا خدماتی یا حداقل ۳ ماه قبل از پایان اعتبار پروانه، اقدامات لازم را به منظور تجدید پروانه و به روز رسانی مستندات عمل آورد.  
نشانی واحد تولیدی / خدماتی: استان تهران، شهرک صنعتی آبدکانه، شهرک صنعتی خلیج فارس، خیابان ۱۲، واحد تولیدی شرکت خلیج فارس  
رعایت مندرجات پشت پروانه برای واصله آن الزامی است.  
مدت اعتبار این پروانه از تاریخ صدور سه سال است (۱۴۰۳/۱۲/۰۵)





جمهوری اسلامی ایران

بیاست جمهوری

سازمان ملی استاندارد ایران

شماره پروانه: ۶۳۷۴۹۱۵۱۷۵

تاریخ صدور اولیه: ۱۳۹۷/۱۲/۰۵

تاریخ تمدید: ۱۴۰۰/۱۲/۰۵

## پروانه کاربرد علامت استاندارد اجباری

براساس قانون تقویت و توسعه نظام استاندارد، مصوب سال یک هزار و سیصد و نود و شش و در اجرای مصوبات شورای عالی استاندارد؛ به موجب این پروانه اجازه داده می شود: شرکت تاسیساتی ساختمانی پاکمن (سهامی خاص) با رعایت قوانین و مقررات مربوطه و استاندارد ملی شماره ۷۵۹۴ از علامت استاندارد ایران برای حصول: مثل همی کازونیل سوز دمنده دار با ویژگی مثل همی با گذر کازونیل کتیریا مساوی ۱۰۰ کیلوگرم بر ساعت، مثل همی با گذر کازونیل میش از ۱۰۰ کیلوگرم بر ساعت با نام یا علامت تجاری ثبت شده به شماره ۲۹۵۴۴۲ مورخ ۱۳۹۶/۱۲/۱۴ (پاکمن PACKMAN) استفاده نماید.

همدی اسلام ناه

رئیس سازمان ملی استاندارد ایران

محمود فرمائی



واحد تولیدی یا خدماتی باید حداقل ۳ ماه قبل از پایان اعتبار پروانه، اقدامات لازم را به منظور تمدید پروانه در روز رسانی مستندات عمل آورد. نشانی واحد تولیدی / خدماتی: همدان-شهرستان نخب-شهرک صنعتی گلرین-خیابان ۱۷۱-دو منش شرقی خیابان ننگر رعایت مندرجات پشت پروانه برای دلنیزه آن الزامی است.

مدت اعتبار این پروانه از تاریخ صدور سه سال است (۱۴۰۳/۱۲/۰۵)



# ЕВРАЗИЙСКИЙ ЭКОНОМИЧЕСКИЙ СОЮЗ



## СЕРТИФИКАТ СООТВЕТСТВИЯ

№ ЕАЭС RU C-IR.БЛ08.В.01522/22

Серия **RU** № **0378484**

**ОРГАН ПО СЕРТИФИКАЦИИ** Орган по сертификации "ИВАНОВО-СЕРТИФИКАТ" Общества с ограниченной ответственностью "Ивановский Фонд Сертификации": Место нахождения (адрес юридического лица): 153032, Россия, Ивановская область, город Иваново, улица Станкостроителей, дом 1, помещение 169, этаж 4; Адрес места осуществления деятельности: 153032, Россия, Ивановская область, город Иваново, улица Станкостроителей, дом 1; Телефон: +7 (4932) 77-34-67; Адрес электронной почты: info@i-f-s.ru; Аттестат аккредитации № RA.RU.11БЛ08 от 24.03.2016 г.

**ИЗГОТОВИТЕЛЬ** Фирма "РАСКМАН", Место нахождения (адрес юридического лица) и адрес места осуществления деятельности: ИСЛАМСКАЯ РЕСПУБЛИКА ИРАН, г. Тегеран, ул. Бохарэст, 10-й переулок, № 2, 4-й этаж. Адрес места осуществления деятельности по изготовлению продукции: ИСЛАМСКАЯ РЕСПУБЛИКА ИРАН, обл. Исфahan, г. Вилашахр, промышленный парк, Монтазерия, ул. 102, № 5.

**ПРОДУКЦИЯ** Горелки газовые блочные промышленные, типы: RGB-M, RPB-M.  
Изготовлена в соответствии с Национальным стандартом BS.EN.676  
Серийный выпуск

КОД ТН ВЭД ЕАЭС 8416201000

СООТВЕТСТВУЕТ ТРЕБОВАНИЯМ ТР ТС 016/2011 "О безопасности аппаратов, работающих на газообразном топливе"

### СЕРТИФИКАТ СООТВЕТСТВИЯ ВЫДАН НА ОСНОВАНИИ

Протокол испытаний

№ 3337/2022 от 05.10.2022 г. – Испытательная лаборатория ООО "ТЕСТ-ИНЖИНИРИНГ" (Аттестат аккредитации № RA.RU.21MP40). Акт анализа состояния производства № 22090902/ТРТС/РА от 14.09.2022 г., выдан ОС "ИВАНОВО-СЕРТИФИКАТ" ООО "Ивановский Фонд Сертификации" (Аттестат аккредитации № RA.RU.11БЛ08). Инструкции по монтажу, техническому обслуживанию и эксплуатации горелки б/н от 01.09.2022 г. Схема сертификации 1с

СРОК ДЕЙСТВИЯ С 07.10.2022 ПО 06.10.2023  
ВКЛЮЧИТЕЛЬНО

Руководитель (уполномоченное  
лицо) органа по сертификации

Эксперт (эксперт-аудитор)  
(эксперты (эксперты-аудиторы))



Иванов Александр Вениаминович  
(Ф.И.О.)

Жин Сергей Александрович  
(Ф.И.О.)

# ЕВРАЗИЙСКИЙ ЭКОНОМИЧЕСКИЙ СОЮЗ

## ПРИЛОЖЕНИЕ

К СЕРТИФИКАТУ СООТВЕТСТВИЯ № ЕАЭС RU C-IR.БЛ08.В.01522/22

Серия **RU** № **0923101**

Стандарты, в результате применения которых на добровольной основе обеспечивается соблюдение требований Технического регламента Таможенного союза

Обозначение стандарта	Наименование стандарта
ГОСТ 21204-97	Горелки газовые промышленные. Общие технические требования
ГОСТ Р 50591-2013	Агрегаты тепловые газопотребляющие. Горелки газовые промышленные. Предельные нормы концентраций NOx в продуктах сгорания

Анализ состояния производства проведен посредством дистанционной оценки.  
Условия хранения конкретного изделия, срок хранения (службы) указываются в прилагаемой к продукции товаросопроводительной и/или эксплуатационной документации.

Руководитель (уполномоченное  
лицо) органа по сертификации

Эксперт (эксперт-аудитор)  
(эксперты (эксперты-аудиторы))

(подпись)

(подпись)



Федосов Александр Вениаминович  
(Ф.И.О.)

Уткин Сергей Александрович  
(Ф.И.О.)



# ЕВРАЗИЙСКИЙ ЭКОНОМИЧЕСКИЙ СОЮЗ



## СЕРТИФИКАТ СООТВЕТСТВИЯ

№ ЕАЭС RU C-IR.БЛ08.В.01521/22

Серия **RU** № **0378483**

**ОРГАН ПО СЕРТИФИКАЦИИ** Орган по сертификации "ИВАНОВО-СЕРТИФИКАТ" Общества с ограниченной ответственностью "Ивановский Фонд Сертификации"; Место нахождения (адрес юридического лица): 153032, Россия, Ивановская область, город Иваново, улица Станкостроителей, дом 1, помещение 169, этаж 4; Адрес места осуществления деятельности: 153032, Россия, Ивановская область, город Иваново, улица Станкостроителей, дом 1; Телефон: +7 (4932) 77-34-67; Адрес электронной почты: info@i-f-s.ru; Аттестат аккредитации № RA.RU.11БЛ08 от 24.03.2016 г.

**ИЗГОТОВИТЕЛЬ** Фирма "РАСКМАН", Место нахождения (адрес юридического лица) и адрес места осуществления деятельности: ИСЛАМСКАЯ РЕСПУБЛИКА ИРАН, г. Тегеран, ул. Бохарэст, 10-й переулок, № 2, 4-й этаж. Адрес места осуществления деятельности по изготовлению продукции: ИСЛАМСКАЯ РЕСПУБЛИКА ИРАН, обл. Исфahan, г. Вилашахр, промышленный парк, Монтазерия, ул. 102, № 5.

**ПРОДУКЦИЯ** Горелки комбинированные блочные промышленные, типы: RLGB-M, RLGB-M/M. Изготовлена в соответствии с Национальным стандартом BS.EN.676  
Серийный выпуск

КОД ТН ВЭД ЕАЭС 8416202000

СООТВЕТСТВУЕТ ТРЕБОВАНИЯМ ТР ТС 016/2011 "О безопасности аппаратов, работающих на газообразном топливе"

### СЕРТИФИКАТ СООТВЕТСТВИЯ ВЫДАН НА ОСНОВАНИИ

Протокол испытаний

№ 3338/2022 от 05.10.2022 г. – Испытательная лаборатория ООО "ТЕСТ-ИНЖИНИРИНГ" (Аттестат аккредитации № RA.RU.21MP40). Акт анализа состояния производства № 22090903/ТРТС/РА от 14.09.2022 г., выдан ОС "ИВАНОВО-СЕРТИФИКАТ" ООО "Ивановский Фонд Сертификации" (Аттестат аккредитации № RA.RU.11БЛ08). Инструкции по монтажу, техническому обслуживанию и эксплуатации горелки б/н от 01.09.2022 г. Схема сертификации 1с

ДОПОЛНИТЕЛЬНАЯ ИНФОРМАЦИЯ (см. Приложение – бланк № 0923100).

СРОК ДЕЙСТВИЯ С 07.10.2022 ПО 06.10.2023  
ВКЛЮЧИТЕЛЬНО

Руководитель (уполномоченное  
лицо) органа по сертификации

Эксперт (эксперт-аудитор)  
(эксперты (эксперты-аудиторы))



Юров Александр Вениаминович

(Ф.И.О.)

М.П. Каролина А. Иваново  
Степанов Сергей Александрович

(Ф.И.О.)



**ПРИЛОЖЕНИЕ**

К СЕРТИФИКАТУ СООТВЕТСТВИЯ № ЕАЭС RU C-IR.БЛ08.В.01521/22

Серия **RU** № **0923100**

Стандарты, в результате применения которых на добровольной основе обеспечивается соблюдение требований Технического регламента Таможенного союза

Обозначение стандарта	Наименование стандарта
ГОСТ 21204-97	Горелки газовые промышленные. Общие технические требования
ГОСТ Р 50591-2013	Агрегаты тепловые газопотребляющие. Горелки газовые промышленные. Предельные нормы концентраций NOx в продуктах сгорания

Анализ состояния производства проведен посредством дистанционной оценки.  
Условия хранения конкретного изделия, срок хранения (службы) указываются в прилагаемой к продукции товаросопроводительной и/или эксплуатационной документации.



Руководитель (уполномоченное лицо) органа по сертификации

Эксперт (эксперт-аудитор)  
(эксперты (эксперты-аудиторы))

*(Handwritten signature)*

Зов Александр Вениаминович

(Ф.И.О.)

М.П.

ИВАНОВО

Уткин Сергей Александрович

(Ф.И.О.)





- SMILE INTO THE FUTURE -

[www.raadmanburner.com](http://www.raadmanburner.com)