

- raadman -
Motor Starter



RMS

Last Update
February 2024

radman

VSD (Variable Speed Drive)



Soft Starter

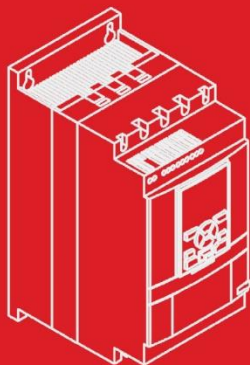

Star-Delta

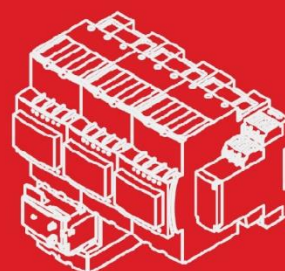

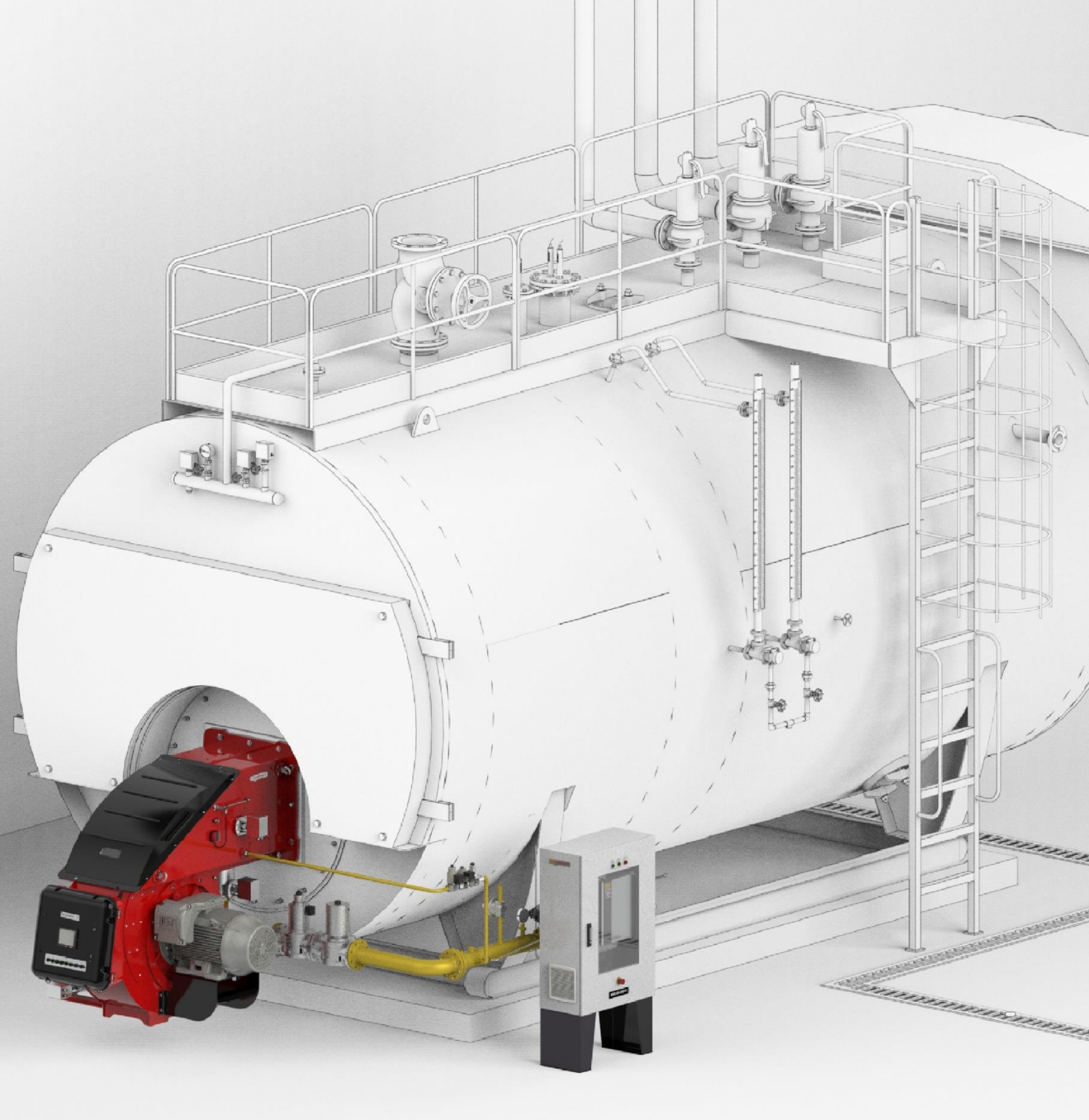

RMS • *A key to a more dominate power system*



- r a a d m a n —

- SMILE INTO THE FUTURE —

raadman burners ventilation motor starter

raadman factory produces burners with firing range of 100 kW to 60000 kW. In burners with ventilation motor capacity of 22kW and above, the power circuit and control circuit need to be installed separately due to destructive effects of electrical noise that power circuit or high voltage has on the control devices. With Regard to this reason, raadman motor starter (RMS) in which the power circuit is embedded, is introduced by the means of this technical document.

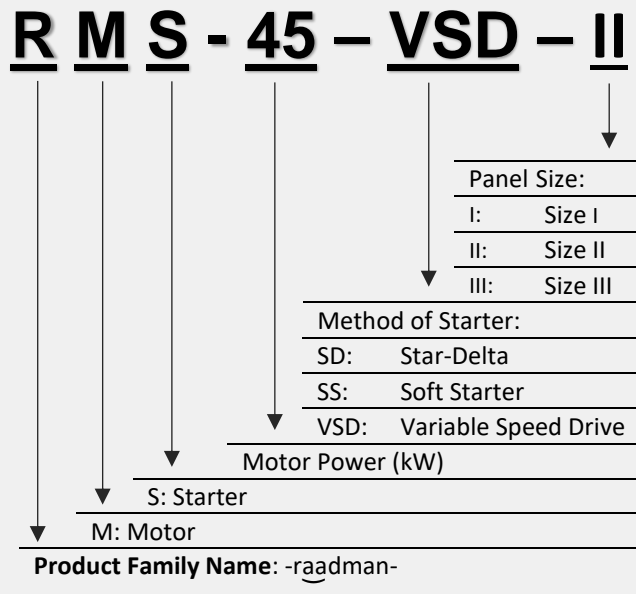

Different starting methods



Star-Delta:

A star-delta starter is the most commonly used method for starting a three-phase induction motor. In star delta starting, an induction motor is connected via a star connection throughout the starting period. In order to use this starting method, the motor must be delta connected during a normal run.

This starting system has some disadvantages that are mentioned below:

- Overload current drawn from electric grid at the time of starting
- Current and mechanical shocks at the load torque starting moment
- Current and mechanical shocks to the motor at the moment of changing status from Star to Delta which reduces the motor useful lifespan
- by increasing the current range, the contactors and bimetals sizes are increased

Soft Starter:

The soft starter makes use of the fact that when the motor voltage is low during start, the starting current and starting torque is also low. During the first part of the start, the voltage to the motor is so low that it is only able to adjust the play between the gear wheels or stretching driving belts, chains, etc. In other words, eliminating unnecessary jerks during the start. Gradually, the voltage and the torque increase so that the machinery starts to accelerate.

This method also has some drawbacks such as:

- high starting current (3 to 5 times of the rated current)
- limitations in number of starting times
- limitations in ambient temperature
- limitations in working cycle and rest period of the device
- high cost
- high sensitivity of power semiconductors

According to the abovementioned limitations, for using soft starter in starting the burner fan, it is necessary to choose a power range which is two times higher than motor power range. Moreover, the soft starter should be selected from among reputable brands

Variable speed drive (VSD):

The frequency converter is also called VSD (Variable Speed Drive), VFD (Variable Frequency Drive) or simply Drive. The drive consists primarily of two parts; one part converts AC (50 or 60 Hz) to DC and the other part converts DC back to AC, but with a variable frequency of 0-250 Hz. The drive can control the motor speed by controlling the frequency.

During start, the drive increases the frequency from 0 Hz up to the network frequency (50 or 60 Hz). By increasing the frequency gradually, the motor can run at its rated speed for that frequency. Since the motor can run at its rated speed, the rated torque is available already from start and the current will be around the nominal current. Normally, the drive trips if the current reaches 1.5 times the rated current.

The followings are limitations of starting with a drive: causing noise and harmonics to the network (needs filter) and high cost

Burner management system overview

Burner management consists of power circuit and control circuit. The control circuit controls the starter signal in the power circuit. The control circuit normally operates at a lower voltage than the power circuit. So, it is better to install power circuit and control circuit separately.

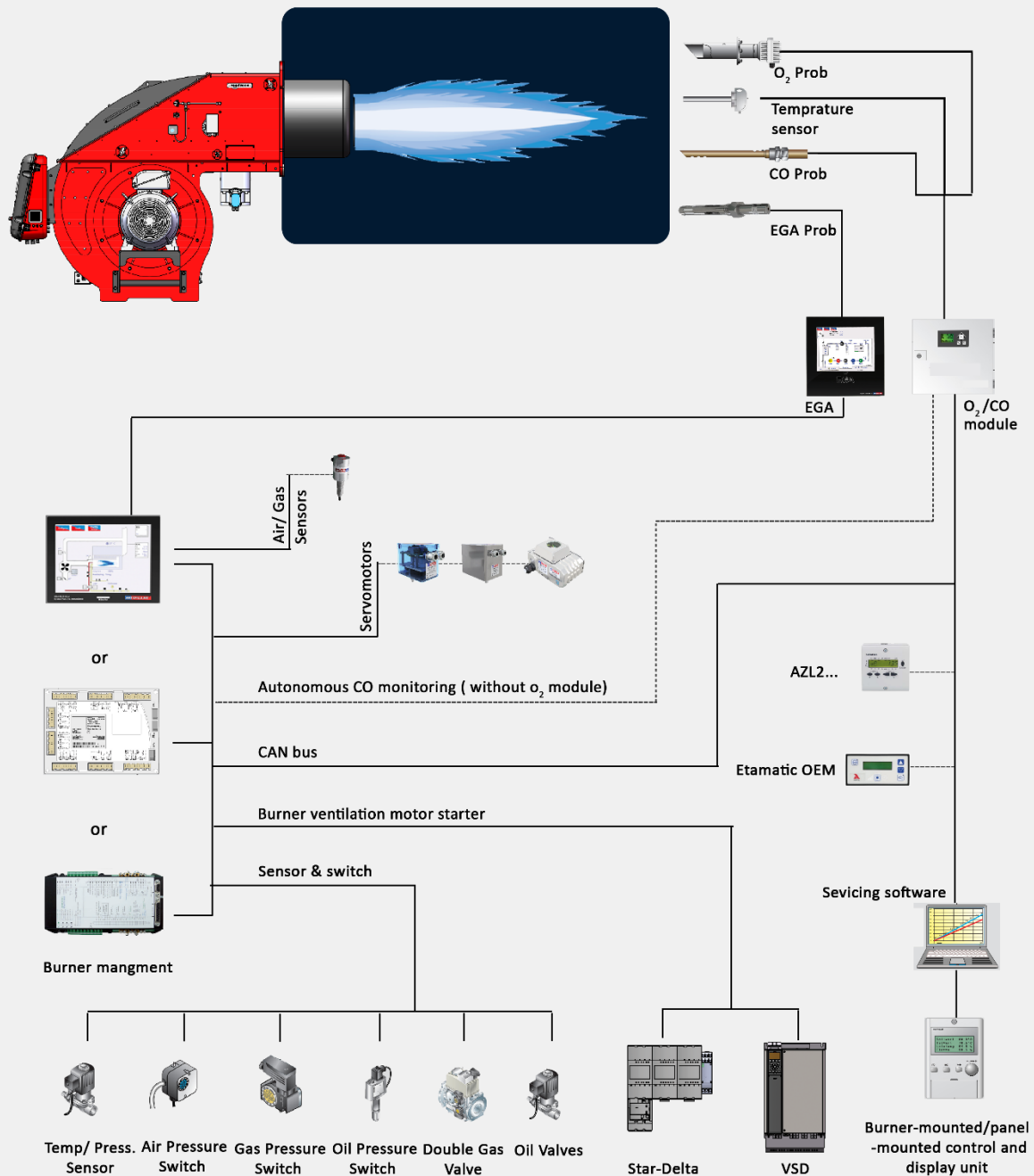



RMS series range

In the following tables, different starting methods for ventilation motors of raadman burners together with appropriate panel sizes are suggested.

Note: In starting the ventilation motor by inverter, different brands can be used such as DELTA, XIMA, DANFOSS, and VORTEX. However, the preferred and standard brand by raadman is Vortex. Also, the preferred brand for starting by Star-Delta is Schneider.

RMS model	Motor(kW/PH/V/HZ/rpm)	Star-Delta*	size
RMS-22-SD-I	22/3/380-400/50/2840	LC1D50, LC1D50, LC1D40, LRD325, RE22R1QCMU	Size I
RMS-30-SD-I	30/3/380-400/50/2840	LC1D65, LC1D65, LC1D50, LRD340, RE22R1QCMU	Size I
RMS-37-SD-I	37/3/380-400/50/2840	LC1D65, LC1D65, LC1D50, LRD350, RE22R1QCMU	Size I
RMS-45-SD-I	45/3/380-400/50/2840	LC1D80, LC1D80, LC1D65, LRD3359, RE22R1QCMU	Size I
RMS-55-SD-I	55/3/380-400/50/2840	LC1D95, LC1D95, LC1D80, LRD3361, RE22R1QCMU	Size I
RMS-75-SD-I	75/3/380-400/50/2900	LC1D115, LC1D115, LC1D95, LRD4365, RE22R1QCMU	Size I
RMS-90-SD-I	90/3/380-400/50/2900	--	--
RMS-110-SD-I	110/3/380-400/50/2900	--	--

RMS model	Motor(kW/PH/V/HZ/rpm)	Inverter	size
RMS-22-VSD-I	22/3/380-400/50/2840	Vortex	Size I
RMS-30-VSD-II	30/3/380-400/50/2840	Vortex	Size II
RMS-37-VSD-II	37/3/380-400/50/2840	Vortex	Size II
RMS-45-VSD-II	45/3/380-400/50/2840	Vortex	Size II
RMS-55-VSD-II	55/3/380-400/50/2840	Vortex	Size II
RMS-75-VSD-II	75/3/380-400/50/2900	Vortex	Size II
RMS-90-VSD-II	90/3/380-400/50/2900	Vortex	Size II
RMS-110-VSD-III	110/3/380-400/50/2900	Vortex	Size III

- For all burners with ventilation motor above 22 kW, the accessories of power system are not included by the burners.
- We recommend to use VSD in order to control the noise level of the burners as well as enhancing the entire capabilities. All customers are welcome to handle the power system by themselves or place an order of RMS (Raadman Motor starter) with us.
- As stated above, we do not recommend start-delta starters for powers above 45 kW. In these cases, VSD is more recommended.
- RMS can also be supplied by soft-starters but it is not recommended.

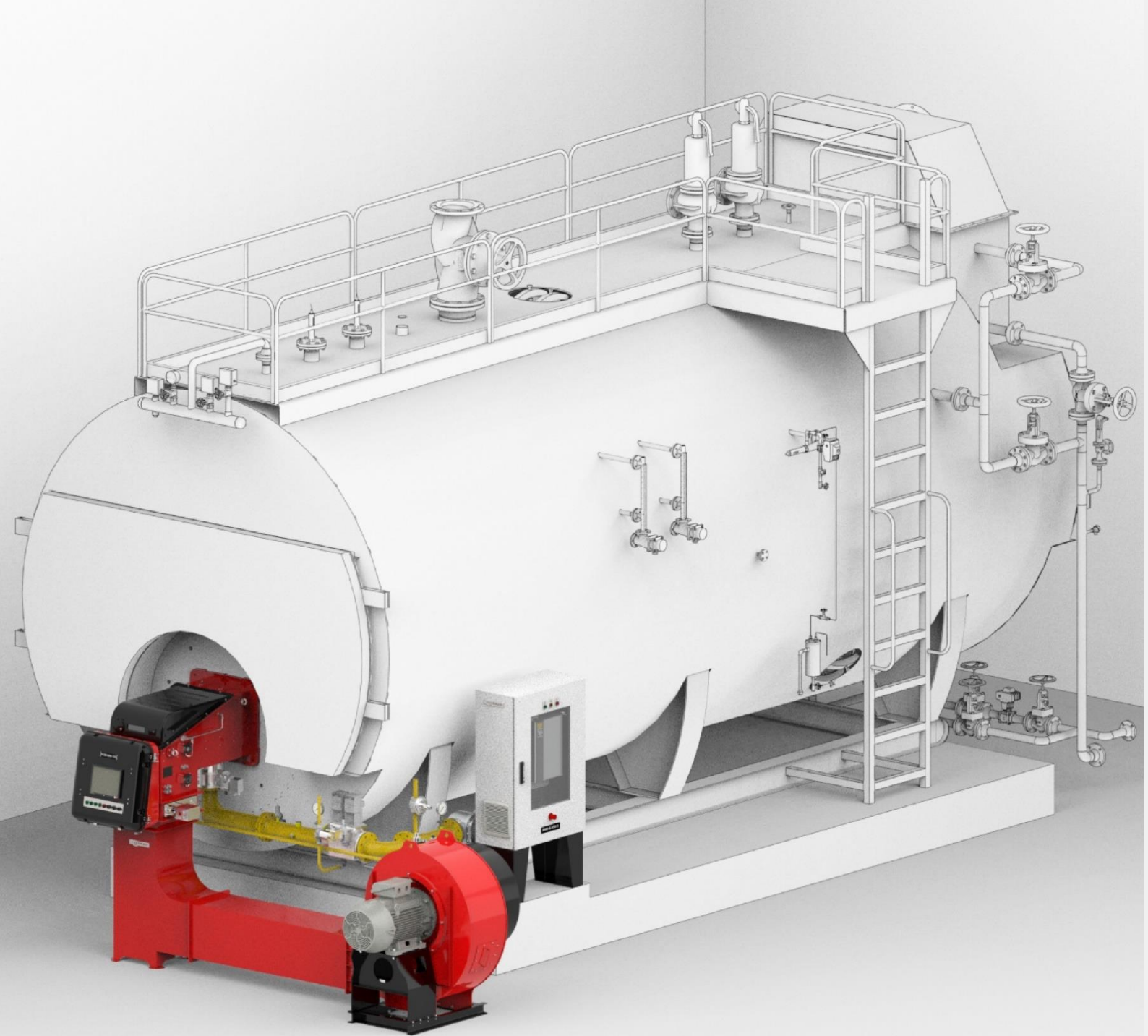

A good power system can increase the device operation and lifespan, prevent consecutive failures, reduce repair and maintenance costs, and provide superior customer comfort.

General dimension: RMS series

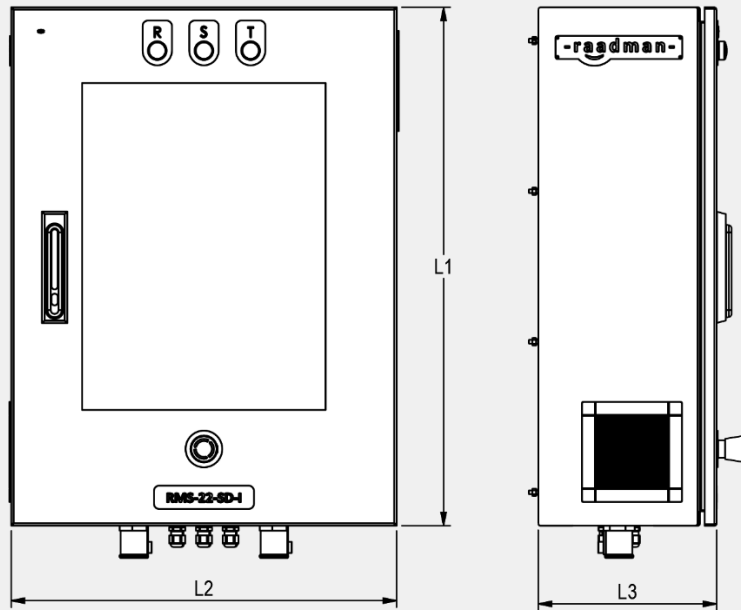

Panel Size	L1	L2	L3
Size I	777 mm	578 mm	268 mm
Size II	1160 mm	800 mm	389 mm
Size III	1260 mm	875 mm	410 mm

RMS series components

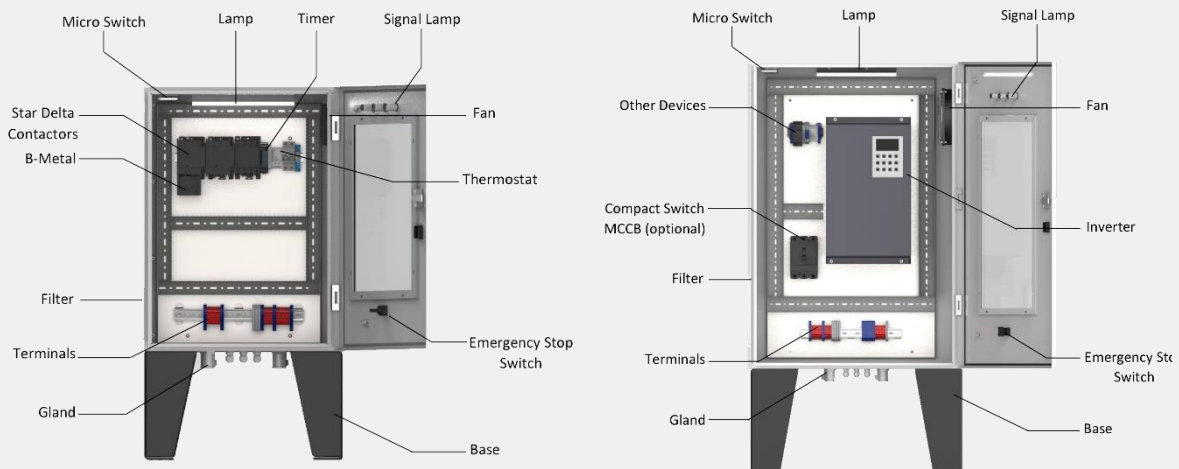

RMS series installation

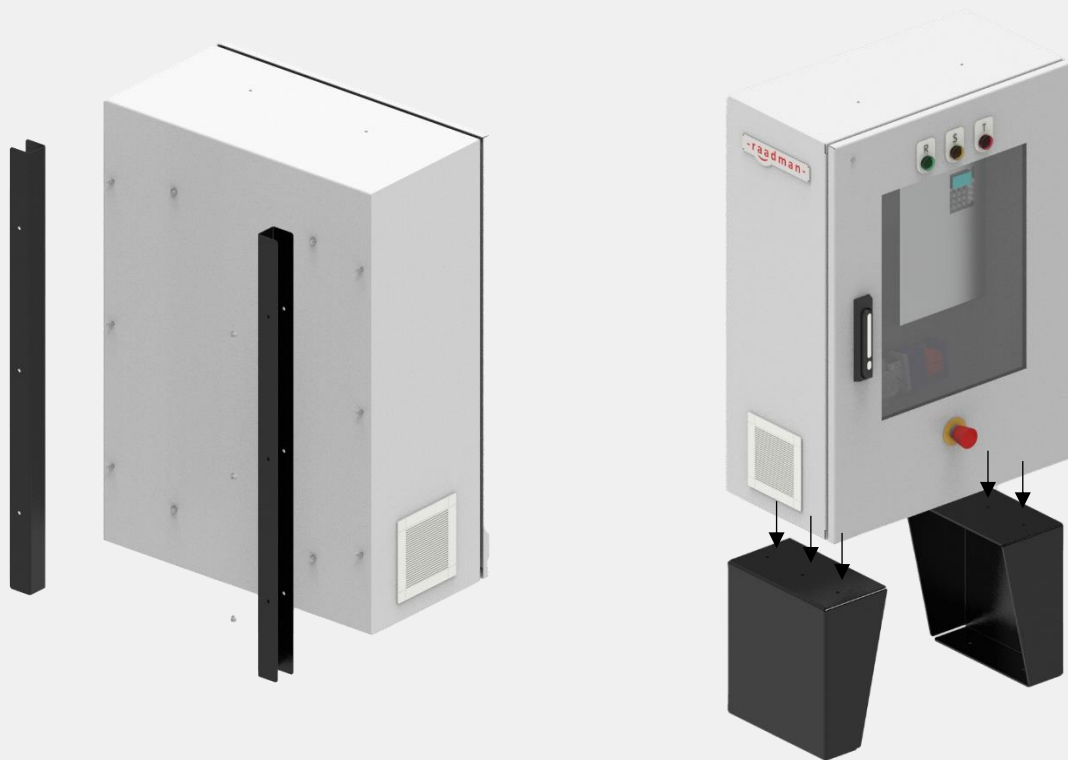

There are two brackets designed to be connected behind the panel which help to install the panel on desired place.

There are two bases to be connected under the panel which can be screwed to the earth. These bases are designed in such a way that electrical wires can be easily connected via glands under the panel.

RMS series IP

IEC (International Electrotechnical Commission) has published standard 60529 for describing a system to classify the degrees of protection provided by the enclosures of electrical equipment. This system is suitable for using with most types of electrical equipment.

IP Code is a coding system to indicate the degrees of protection provided by an enclosure against access to hazardous parts, ingress of solid objects and water. It also provides detailed information regarding the protection.

raadman electrical panels have a high degree of protection (IP 54) due to the following features:

- electrostatic coating that provides high resistance against changes in temperature, humidity, freezing and cold.
- the fan and filter have been selected from among reputable brands that not only exchange the air and cool the panel, but also keep the panel IP at a high level.
- using polyurethane foam between the panel's door and body prevents the ingress of water, steam, and dust to electrical panel.



VSD wiring diagram

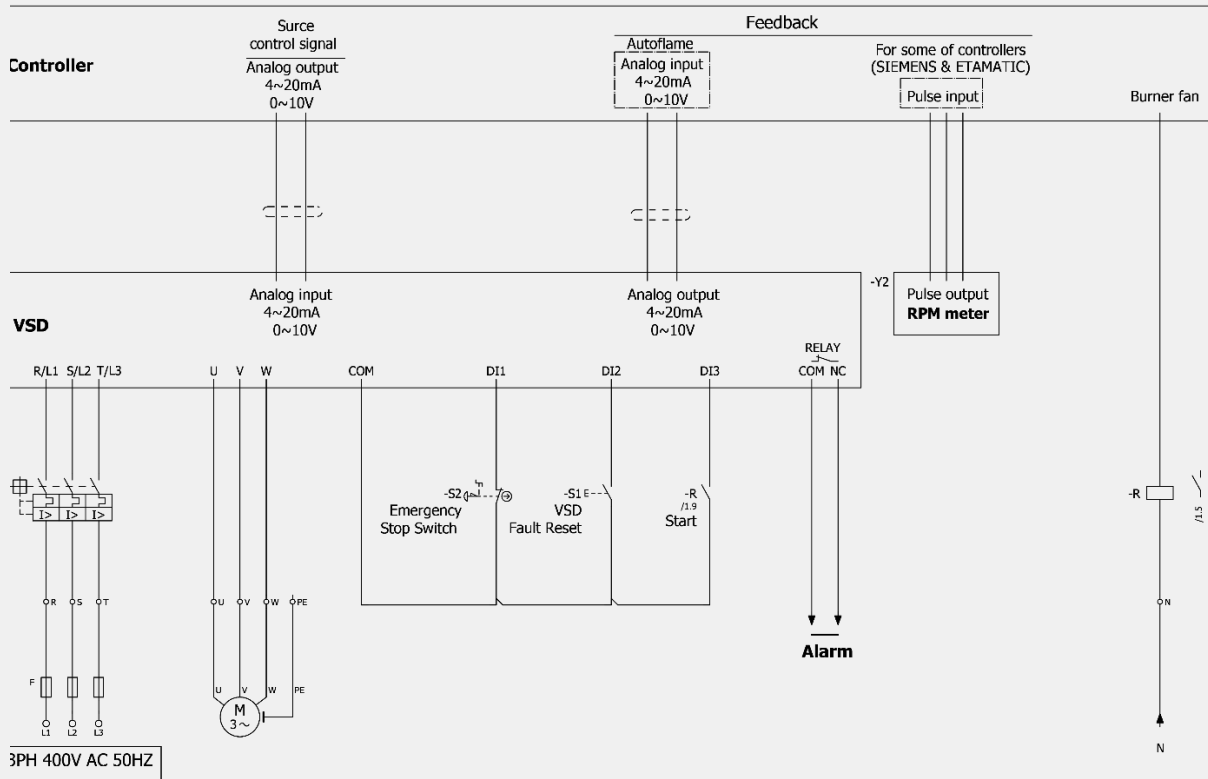

Star-Delta wiring diagram

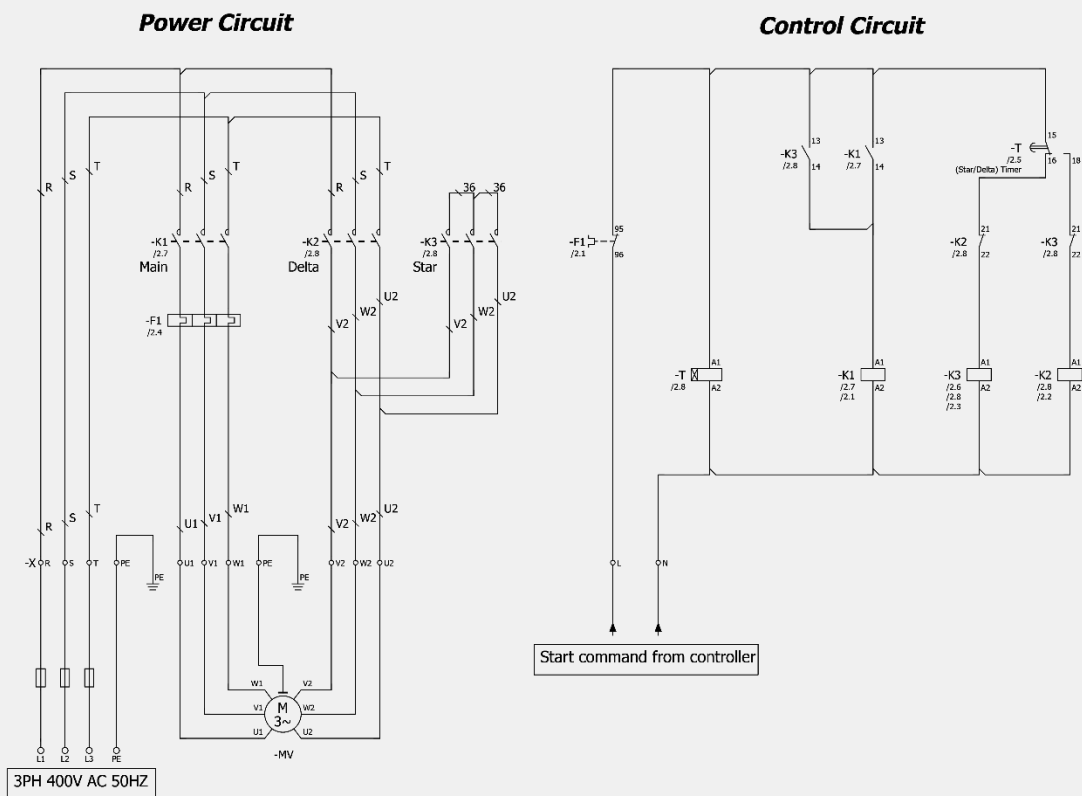

Contact us



Central Office

Address: 4th floor, No2, 10th St, Ahmad Ghasir Ave, Tehran, Iran

Phone: (+9821) 42362

Fax: (+9821)88737131

www.packmangroup.com



Burner Factory

Address: No. 5, 102 Ave. Montazeriye Industrial Town, Vilashahr, Isfahan, Iran

Phone: (+9831) 42290483

information center

Mobile Phone (Telegram & Whatsapp): (+98) 913 429 4984

Email: info@raadmanburner.com

International sales

Mobile Phone (Telegram & Whatsapp): (+98) 913 429 4965

Email: Sales@raadmanburner.com

Support center

Mobile Phone (Telegram & Whatsapp): (+98) 913 429 4981

Email: Support@raadmanburner.com

www.raadmanburner.com

Note

A series of horizontal dotted lines for writing notes.

Note

A series of horizontal dotted lines intended for taking notes.



- SMILE INTO THE FUTURE -

www.raadmanburner.com