



RGB-20, Staging Gas Burner

Specifications

- One Stage burner with capacity of 85-215 kW on gas side (8.5-21.5 Nm³/h for G20), and turn down ratio of 1:2, and NOx class I.
- Compatible with all types of combustion chambers according to EN-303 or BS-EN 12953-3 standards.
- Suitable for firetube, firebox and water tube boilers.
- Burner includes: aluminum housing, flame tube, electrical wiring, air fan, control panel, ignition devices, valves and all necessary safety devices in the gaseous fuel line.
- Burner controller: HONEYWELL DLG
Controller includes: Main controller, actuator.
- Gas train includes: filter, regulator, main and safety valve, pressure gauges, minimum and pressure switch (according to BS-EN 676).
Gas train is provided in two types depends on the applications:
 - Rp¼ multi-block low-pressure gas train (inlet pressure of 29-360 mbar).
 - Rp1 separate low-pressure gas train (inlet pressure of 16-360 mbar).
- Advantages: Optimal design, silent operation and easy installation and maintenance.
- Optional ability: LPG fuel compatibility with LPG nozzle kits.



More information

- Fan motor: 0.3 kW, 1 Phase, 220 Volt, 50 Hz, 2700 rpm.
 - Operating ambient temperature: 5-60°C
 - Maximum combustion air temperature: 60°C
 - Noise emission level: 65 dB in 1.5-meter distance
 - Casing insulation class: IP43
 - Net weight: 18 kg
 - Packing dimensions (length x width x height): 690 x 430 x 440 mm
- Reference conditions: Ambient temperature 20°C - Gas temperature 15°C
- Barometric pressure 1013 mbar - Altitude 0 m (according to BS-EN 676)

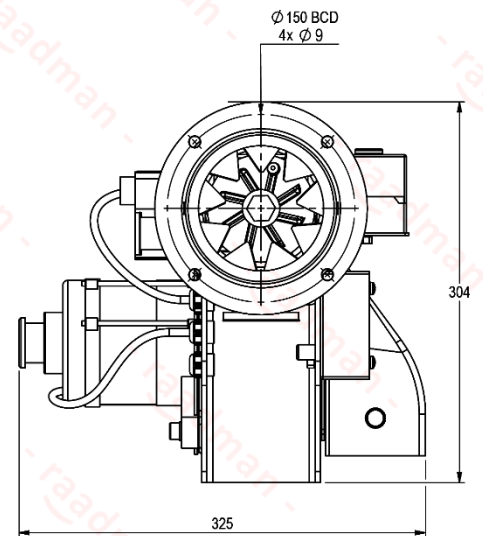
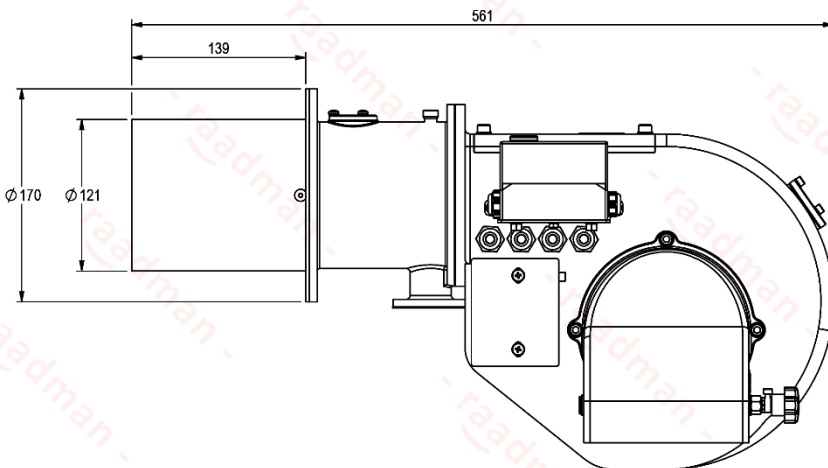
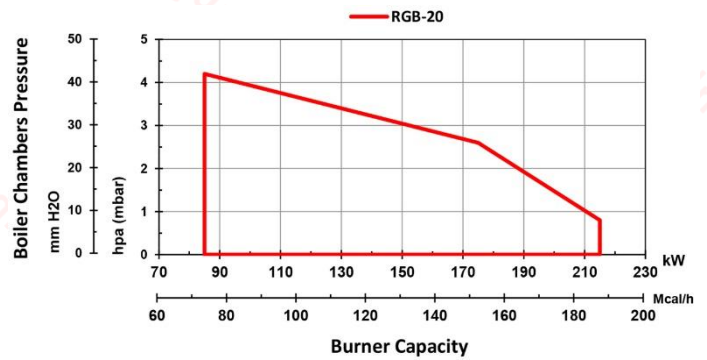

- Suggested boiler flange diameter = 133 mm

Certifications

- Certified in EAEU countries standard No. 0378484.
- Certified in Iran national standard ISIRI-7595 (BS-EN 676).



Scan to access:
 Technical proposal
 Technical data
 Technical consultation
 Cad model (only for VIP customers)

