



RGB-405/LN, Low NOx Staging Gas Burner

Specifications

- Two stage burner with capacity of 680-4100 kW on gas side (68-410 Nm³/h for G20), and turn down ratio of 1:6, and NOx class III.
- Compatible with all types of combustion chambers according to EN-303 or BS-EN 12953 standards.
- Suitable for fire tube, fire box, water tube boilers, etc.
- The burner includes: mechanical components, low NOx burner head designed for emission reduction, flame tube, air fan, control panel, ignition devices, valves and all necessary safety devices in the gaseous line.
- Burner controller: SIEMENS LFL
- The controller includes: main controller, actuators.
- The gas train includes: filter, regulator, main and safety valve, pressure gauges, maximum pressure switch, minimum and leak test pressure switch, valve proving system (All according to BS-EN 676).
The recommended gas train is offered only in one type:
 - DN65 separate low-pressure gas train (inlet pressure of 150-360 bar).
 - If higher pressures are available, lower gas train sizes can be offered for better prices.
- Advantages: optimal design, high modulating ratio, silent operation, the ability to open from the hinge to both sides and ease of installation and maintenance.

Optional ability: LPG fuel compatibility with LPG nozzle kits.

More information

- Fan motor: 9.2 or 11 kW, 3 Phase, 380-400 Volt, 50 Hz, 2900 rpm.
- Operating ambient temperature: 5-60°C
- Maximum combustion air temperature: 60°C
- Noise emission level: 83 dB in 1.5-meter distance
- Casing insulation class: IP43
- Net weight: ~210 kg
- Packing dimensions (L x W x H): ~1850 x 1140 x 870 mm

Reference conditions: Ambient temperature 20°C - Gas temperature 15°C
- Barometric pressure 1013 mbar - Altitude 0 m (According to BS-EN 676)

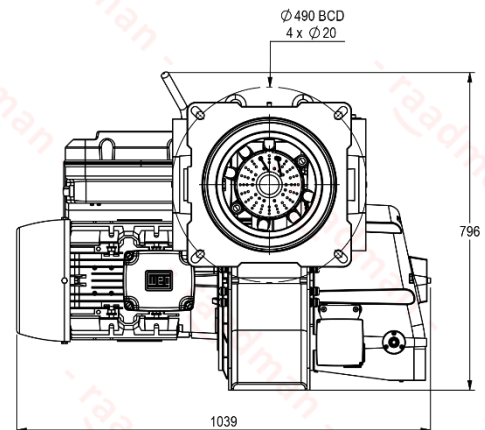
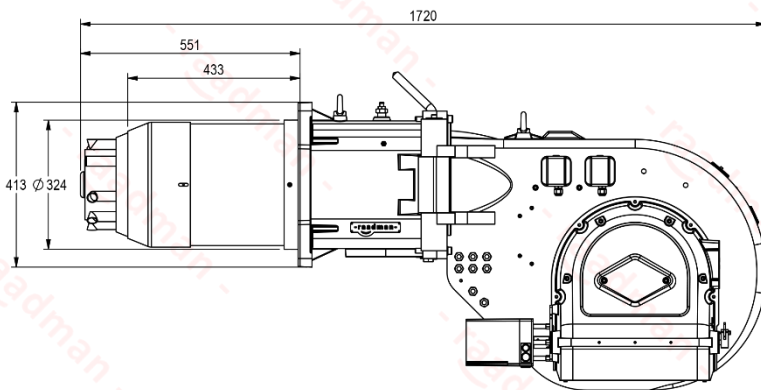
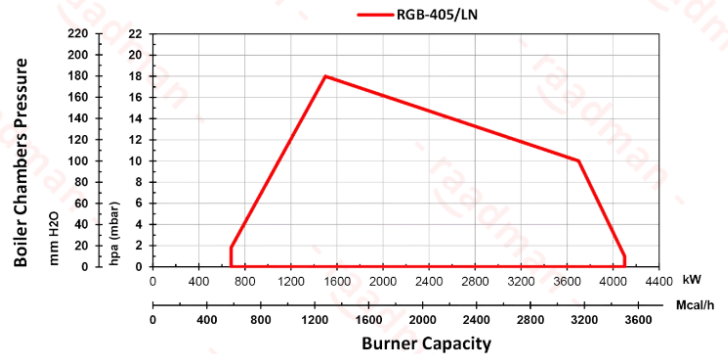

- Suggested boiler flange diameter = 335 mm

Certifications

- Certified in EAEU countries standard No. 0378484.
- Certified in Iran national standard ISIRI-7595 (BS-EN 676).



Scan to access:
 Technical proposal
 Technical data
 Technical consultation
 Cad model (only for VIP customers)

