



RGB-M-1550, Electronic Modular Gas Burner

Specifications

- Electronic modulating burner with capacity of 1900-15000 kW on gas side (100-900 Nm³/h for G20), and turn down ratio of 1:8, and NOx class II.
- Compatible with all types of combustion chambers according to EN-303 or BS-EN 12953 standards.
- Suitable for fire tube, firebox, water tube boilers, etc.
- The burner includes: mechanical components, burner head, flame tube, air fan, control panel, ignition devices, valves and all necessary safety devices in the gaseous fuel line.
- Burner controller: AUTOFLAME MINI MK8/MK8 or SIEMENS LMV5 depends on the policy of the manufacturer based on the market availability or the customer's order.
- The controller includes: main controller (PID controller), user interface, flame scanner, and actuators.
- The gas train includes: filter, regulator, main and safety valve, pressure gauges, maximum pressure switch, minimum and leak test pressure switch (All according to BS-EN 676).
The recommended gas trains are offered in two types:
 - DN100 separate low-pressure gas train (inlet pressure of 250-360 mbar).
 - DN100 separate high-pressure gas train (inlet pressure of 1-4 bar).
- Advantages: optimal design, high modulating ratio, silent operation, valve proving system, communication with external systems via Bus, and ease of installation and maintenance.
- Optional ability: running with FGR (Flue Gas Recirculation) in order to further reduction in NOx level, variable speed drive (VSD), running with O₂ and CO sensors (plus CO₂, NO, NO₂, and SO₂ sensors with AUTOFLAME controller), LPG fuel compatibility with LPG nozzle kits.



More information

- Fan motor: 45 kW, 3 Phase, 380-400 Volt, 50 Hz, 2900 rpm.
- Operating ambient temperature: 5-60°C
- Maximum combustion air temperature: 60°C
- Noise emission level: 89 dB in 1.5-meter distance
- Casing insulation class: IP43
- Net weight: ~1280 kg ±1%
- Packing dimensions (L x W x H): ~2730 x 1850 x 2060 mm

Reference conditions: Ambient temperature 20°C - Gas temperature 15°C - Barometric pressure 1013 mbar - Altitude 0 m (According to BS-EN 676).

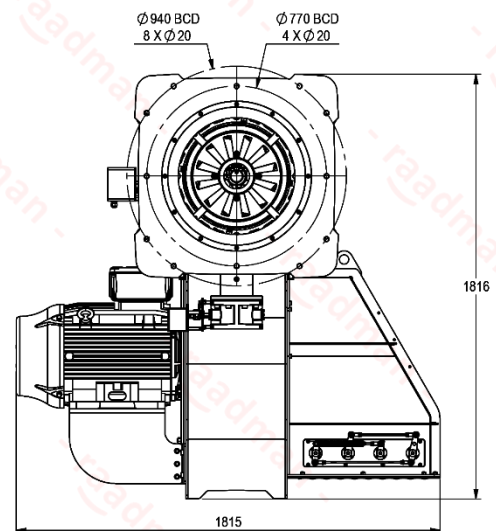
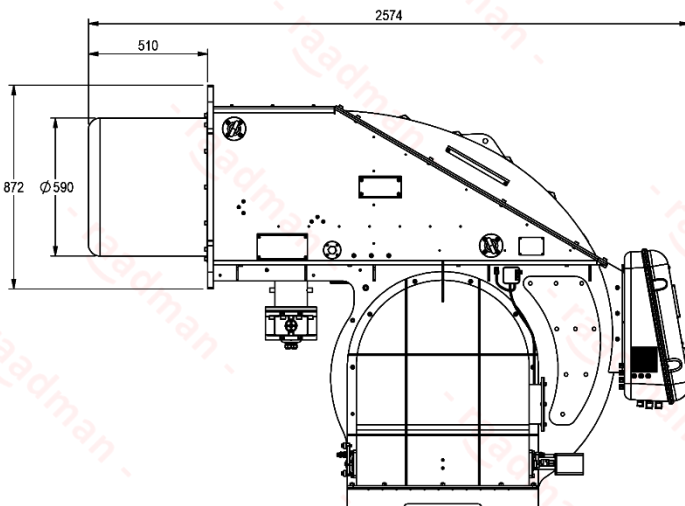
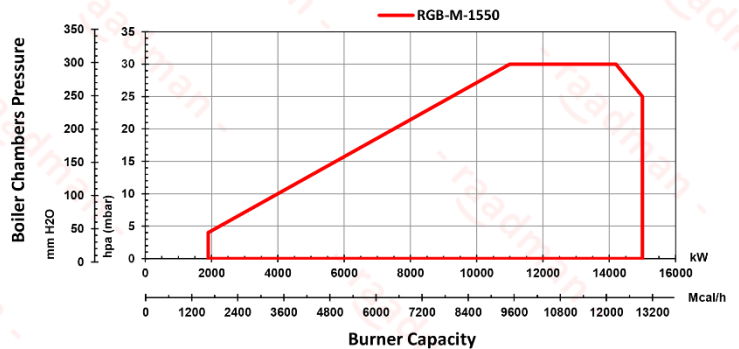

- Suggested boiler flange diameter = 602 mm

Certifications

- Certified in EAEU countries standard No.0378484.
- Certified in Iran national standard ISIRI-7595 (BS-EN 676).



Scan to access:
Technical proposal
Technical data
Technical consultation
Cad model (only for VIP customers)

