

## RGB-M-185, Electronic Modulating Gas Burner

### Specifications

- Electronic modulating burner with capacity of 470-1870 kW on gas side (47-187 Nm<sup>3</sup>/h for G20), and turn down ratio of 1:4, and NOx class II.
- Compatible with all types of combustion chambers according to EN-303 or BS-EN 12953 standards.
- Suitable for fire tube, firebox, water tube boilers, etc.
- The burner includes: mechanical components, burner head, flame tube, air fan, control panel, ignition devices, valves and all necessary safety devices in the gaseous fuel line.
- Burner controller: AUTOFLAME MINI MK8 (in burner/boiler package), or SIEMENS LMV2/3 depends on the policy of the manufacturer based on the market availability or the customer's order.
- The controller includes: main controller (PID controller), load control module, user interface, and actuators.
- The gas train includes: filter, regulator, main and safety valve, pressure gauges, maximum pressure switch, minimum and leak test pressure switch (All according to BS-EN 676).

The recommended gas trains are offered in two types:

- Rp2 multi-block low-pressure gas train (inlet pressure of 70-360 mbar).
- Rp2 separate low-pressure gas train (inlet pressure of 105-360 mbar).
- If higher pressures are available, lower gas train sizes can be offered for better prices.
- Advantages: optimal design, high modulating ratio, silent operation, valve proving system, communication with external systems via Bus, the ability to open from the hinge to both sides, and ease of installation and maintenance.
- Optional ability: running with FGR (Flue Gas Recirculation) in order to further reduction in NOx level, running with O<sub>2</sub> and CO sensors (plus CO<sub>2</sub>, NO, NO<sub>2</sub>, and SO<sub>2</sub> sensors with AUTOFLAME controller), LPG fuel compatibility with LPG nozzle kits.



### More information

- Fan motor: 5.5 kW, 3 Phase, 380-400 Volt, 50 Hz, 2840 rpm.
- Operating ambient temperature: 5-60°C
- Maximum combustion air temperature: 60°C
- Noise emission level: 80.5 dB in 1.5-meter distance
- Casing insulation class: IP43
- Net weight: ~92 kg
- Packing dimensions (L x W x H): ~1350 x 840 x 730 mm

Reference conditions: Ambient temperature 20°C - Gas temperature 15°C  
- Barometric pressure 1013 mbar - Altitude 0 m (According to BS-EN 676)

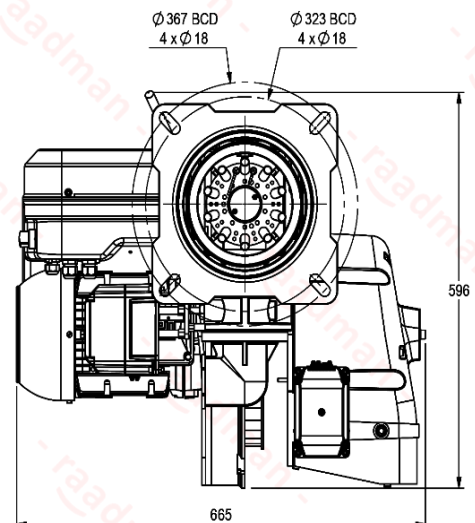
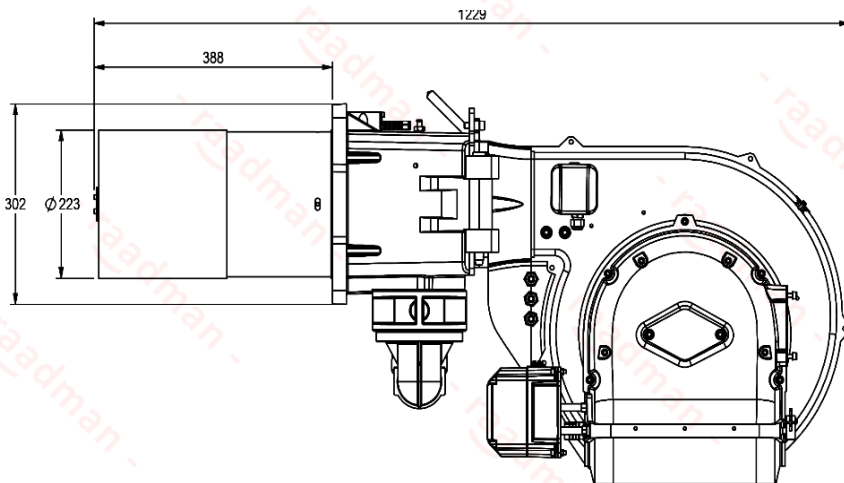
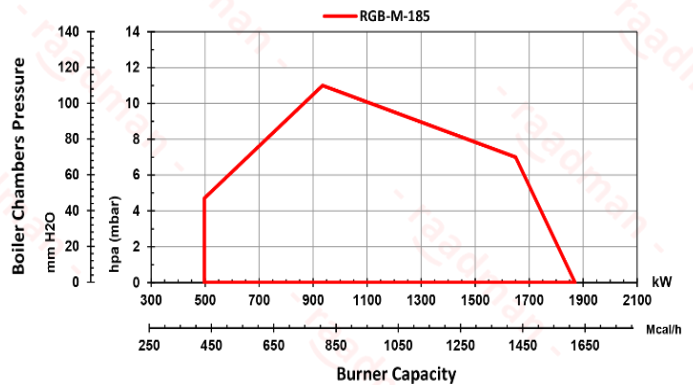

- Suggested boiler flange diameter = 235 mm

### Certifications

- Certified in EAEU countries standard No.0378484.
- Certified in Iran national standard ISIRI-7595 (BS-EN 676).



Scan to access:  
 Technical proposal  
 Technical data  
 Technical consultation  
 Cad model (only for VIP customers)

