



RGB-M-2250, Electronic Modular Gas Burner

Specifications

- Electronic modulating burner with capacity of 2750-22000 kW on gas side (275-220 Nm³/h for G20), and turn down ratio of 1:8, and NOx class II.
- Compatible with all types of combustion chambers according to EN-303 or BS-EN 12953 standards.
- Suitable for fire tube, fire box, water tube boilers, etc.
- The burner includes: mechanical components, burner head, flame tube, air fan, control panel, external electrical panel for soft starter, ignition devices, air pressure switches, ignition transformers, valves and all necessary safety devices in the gaseous fuel lines.
- Burner controller: AUTOFLAME MINI MK8/MK8 or SIEMENS LMV5, depends on the policy of the manufacturer based on the market availability or the customer's order.
- The controller includes: main controller (PID controller), user interface, flame detector, actuators.
- The gas train includes: filter, regulator, main and safety valve, pressure gauges, maximum pressure switch, minimum and leak test pressure switch, pilot regulator, pilot valves, butterfly valve, (All according to BS-EN 676).

The recommended gas trains are offered in two types:

- DN125 multi block low-pressure gas train (inlet pressure of 410-500 mbar).
- DN100 multi block high-pressure gas train (inlet pressure of 2-4 bar).

- Advantages: optimal design, high modulating ratio, silent operation, valve proving system, communication with external systems via Bus, rail system for ergonomic servicing of the mixing assembly, ease of installation and maintenance.
- Optional ability: running with FGR (Flue Gas Recirculation) in order to further reduction in NOx level, variable speed drive, running with O₂ and CO sensors (plus CO₂, NO, NO₂, and SO₂ sensors with AUTOFLAME controller), LPG fuel compatibility with LPG nozzle kits.



More information

- Fan motor: 75 kW, 3 Phase, 380-400 Volt, 50 Hz, 2900 rpm
- Operating ambient temperature: 5-60°C
- Maximum combustion air temperature: 60°C
- Noise emission level: 93 dB in 1.5-meter distance.
- Casing insulation class: IP43
- Net weight: ~1800 kg
- Packing dimensions (L x W x H): ~3050 x 2150 x 2150 mm

Reference conditions: Ambient temperature 20°C - Gas temperature 15°C - Barometric pressure 1013 mbar - Altitude 0 m (According to BS-EN 676)

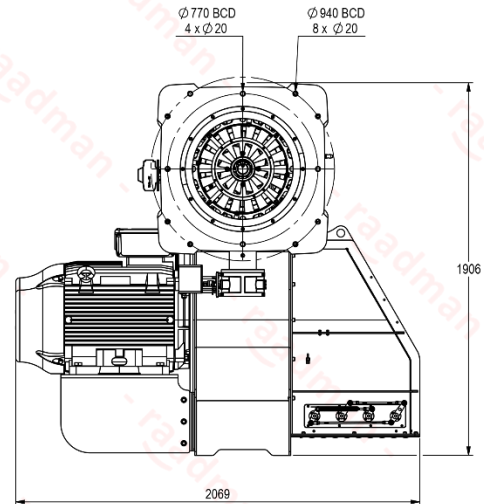
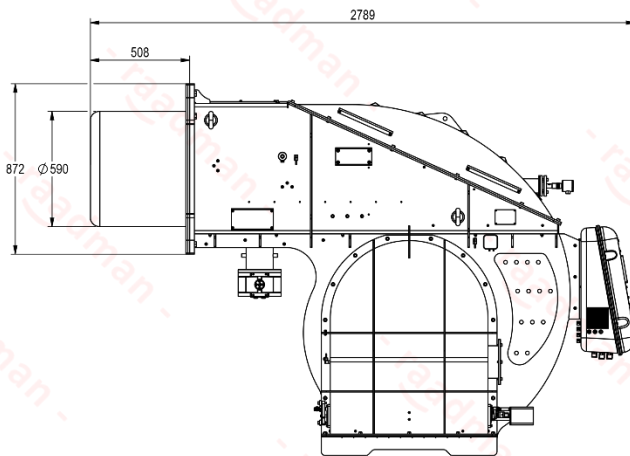
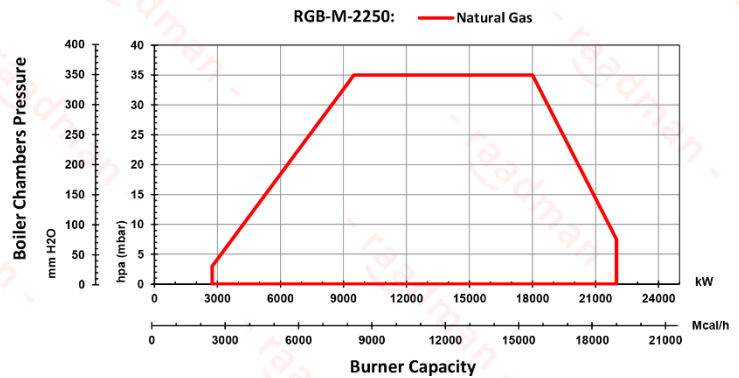

Certifications

- Certified in EAEU countries standard No. 0378484.
- Certified in Iran national standard ISIRI-7595 (BS-EN 676).



Scan to access:
 Technical proposal
 Technical data
 Technical consultation
 Cad model (only for VIP customers)

