



**RGB-M-805-DB-SF, Electronic Modular Gas Burner (Dual block configuration)**

**Specifications**

- Electronic modulating burner with capacity of 1000-8000 kW on gas side (100-800 Nm<sup>3</sup>/h for G20), and turn down ratio of 1:8, and NOx class II.
  - Compatible with all types of combustion chambers according to EN-303 or BS-EN 12953 standards.
  - Suitable for fire tube, fire box, water tube boilers, etc.
  - The burner includes: mechanical components, burner head, flame tube, control panel, ignition devices, air pressure switches, Ignition transformers, valves and all necessary safety devices in the gaseous fuel lines.
  - Burner controller: AUTOFLAME MINI MK8/MK8 or SIEMENS LMV5 depends on the policy of the manufacturer based on the market availability or the customer's order.
  - The controller includes: main controller (PID controller), user interface, flame detector, actuators.
  - Burner ventilation system with 9200 m<sup>3</sup>/h capacity and 55 millibar supply pressure.
  - The BVS includes: Fan motor, mechanical components, FGR (optional) and sound proofing material for further reduction in sound level (optional).
  - The RMS includes: Inverter, fan, Emergency switch, Compact switch MCCB (optional) and electrical components for power system.
  - The gas train includes: filter, regulator, main and safety valve, pressure gauges, maximum pressure switch, minimum and leak test pressure switch, pilot regulator, pilot valves, butterfly valve, (All according to BS-EN 676).
- The recommended gas trains are offered in two types:
- DN100 Multi-block low-pressure gas train (inlet pressure of 235-360 mbar).
  - DN100 Separate low-pressure gas train (inlet pressure of 167-360 mbar).
- Advantages: optimal design, high modulating ratio, valve proving system, communication with external systems via Bus, ease of installation and maintenance.
  - Optional ability: running with FGR (Flue Gas Recirculation) in order to further reduction in NOx level, variable speed drive, running with O<sub>2</sub> and CO sensors (plus CO<sub>2</sub>, NO, NO<sub>2</sub>, and SO<sub>2</sub> sensors with AUTOFLAME controller), LPG fuel compatibility with LPG nozzle kits.



**More information**

- BVS motor: 22 kW, 3 Phase, 380-400 Volt, 50 Hz, 2900 rpm
  - Operating ambient temperature: 5-60°C
  - Maximum combustion air temperature: 60°C
  - Casing insulation class: IP43
  - Combustion block weight: 420 kg ±1%
  - Combustion block Packing dimensions (L x W x H): ~1800 x 990 x 1100 mm
- Reference conditions: Ambient temperature 20°C - Gas temperature 15°C - Barometric pressure 1013 mbar - Altitude 0 m (According to BS-EN 676)

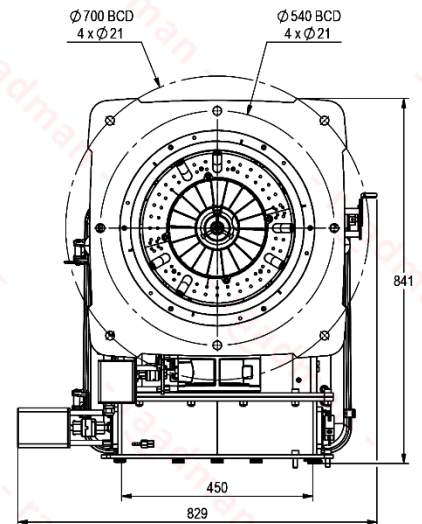
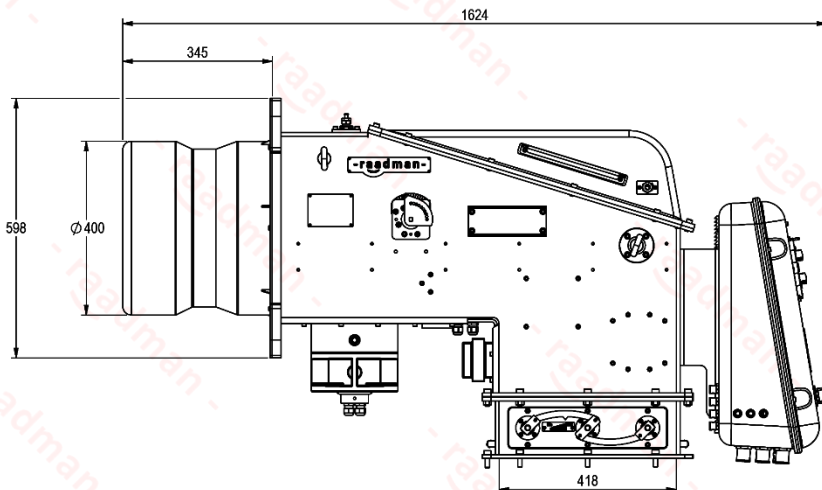
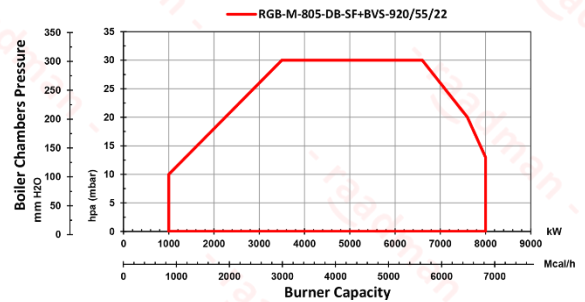

- Suggested boiler flange diameter = 415 mm

**Certifications**

- Certified in EAEU countries standard No. 0378484.
- Certified in Iran national standard ISIRI-7595 (BS-EN 676).



Scan to access:  
 Technical proposal  
 Technical data  
 Technical consultation  
 Cad model (only for VIP customers)

