



RGB-M-805-SF, Electronic Modular Gas Burner (Short flame)

Specifications

- Electronic modulating burner with capacity of 1000-8000 kW on gas side (100-800 Nm³/h for G20), and turn down ratio of 1:8, and NO_x class II.
- Compatible with all types of combustion chambers according to EN-303 or BS-EN 12953 standards.
- Suitable for fire tube, firebox, water tube boilers, etc.
- The burner includes: mechanical components, burner head, flame cover, air fan, control panel, ignition devices, valves, and all necessary safety devices in the gaseous fuel line.
- Burner controller: AUTOFLAME MINI MK8 (in burner/boiler package)
- The controller includes: main controller (PID controller), load control module, flame detector, user interface, and actuators.
- The gas train includes: filter, regulator, main and safety valve, pressure gauges, maximum pressure switch, minimum pressure switch, and leak test pressure switch (All according to BS-EN 676).

The recommended gas trains are offered in two types:

- DN80 multi block low-pressure gas train (inlet pressure of 235-360 mbar).
- DN100 separate low-pressure gas train (inlet pressure of 167-360 bar).
- If higher pressures are available, lower gas train sizes can be offered for better prices.
- Advantages: optimal design, high modulating ratio, silent operation, valve proving system, communication with external systems via Bus, the ability to open from the hinge to both sides, and ease of installation and maintenance.
- Optional ability: running with FGR (Flue Gas Recirculation) in order to further reduction in NO_x level, variable speed drive (VSD), running with O₂ and CO sensors (plus CO₂, NO, NO₂, and SO₂ sensors with AUTOFLAME controller), LPG fuel compatibility with LPG nozzle kits.



More information

- Fan motor: 18.5 kW, 3 Phase, 380-400 Volt, 50 Hz, 2900 rpm.
- Operating ambient temperature: 5-60°C
- Maximum combustion air temperature: 60°C
- Noise emission level: 89 dB in 1.5-meter distance
- Casing insulation class: IP43
- Net weight: ~420 kg
- Packing dimensions (L x W x H): ~2240 x 1600 x 1200 mm

Reference conditions: Ambient temperature 20°C - Gas temperature 15°C - Barometric pressure 1013 mbar - Altitude 0 m (According to BS-EN 676)

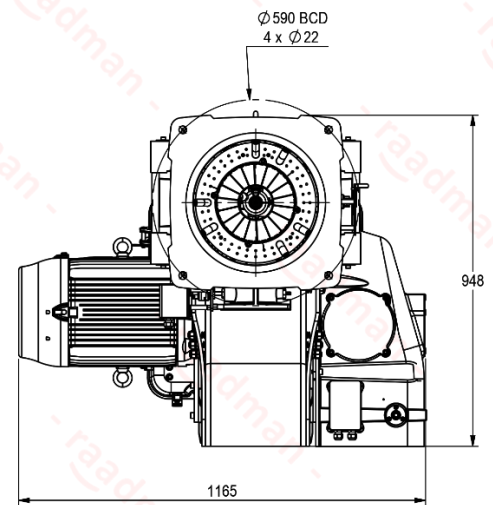
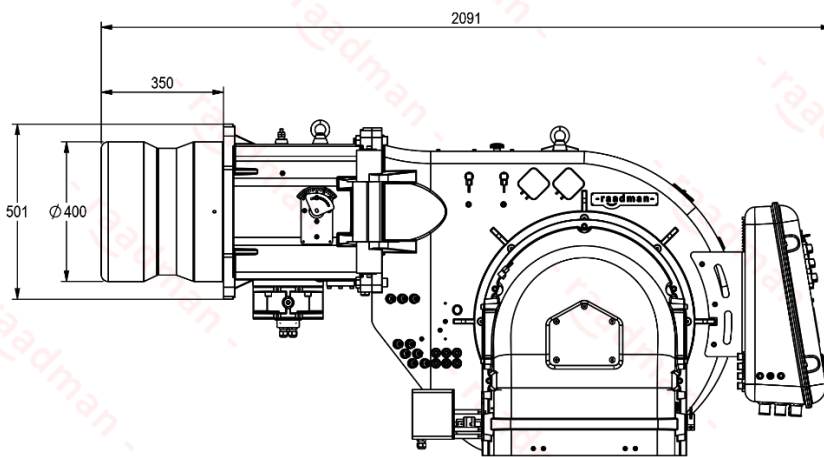
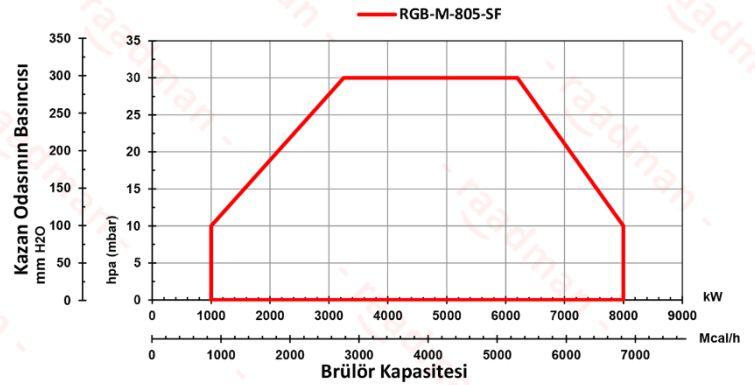

- Suggested boiler flange diameter = 415 mm

Certifications

- Certified in EAEU countries standard No.0378484.
- Certified in Iran national standard ISIRI-7595 (BS-EN 676).



Scan to access:
Technical proposal
Technical data
Technical consultation
Cad model (only for VIP customers)

