



RGB-M-85/LN, Electronic Modular Gas Burner

Specifications

- Electronic modulating burner with capacity of 250-900 kW on gas side (25-90 Nm³/h for G20), and turn down ratio of 1:3, and NO_x class III.
- Compatible with all types of combustion chambers according to EN-303 or BS-EN 12953 standards.
- Suitable for fire tube, firebox, water tube boilers, etc.
- The burner includes: mechanical components, low NO_x burner head designed for emission reduction, flame tube, air fan, control panel, ignition devices, valves and all necessary safety devices in the gaseous fuel line.
- Burner controller: AUTOFLAME MINI MK8 (in burner/boiler package), and LAMTEC BT or SIEMENS LMV2/3 depends on the policy of the manufacturer based on the market availability or the customer's order.
- The controller includes: main controller (PID controller), load control module, user interface, and actuators.
- The gas train includes: filter, regulator, main and safety valve, pressure gauges, minimum pressure switch (All according to BS-EN 676).

The recommended gas trains are offered in two types:

- Rp1 ½ multi-block low-pressure gas train (inlet pressure of 44-360 mbar).
- Rp1 ½ separate low-pressure gas train (inlet pressure of 53-360 mbar).
- If higher pressures are available, lower gas train sizes can be offered for better prices.
- Advantages: optimal design, high modulating ratio, silent operation, communication with external systems via Bus, the ability to open from the hinge to both sides, and ease of installation and maintenance.
- Optional ability: running with O₂ and CO sensors (plus CO₂, NO, NO₂, and SO₂ sensors with AUTOFLAME controller), LPG fuel compatibility with LPG nozzle kits.



More information

- Fan motor: 1.5 kW, 3 Phase, 380-400 Volt, 50 Hz, 2890 rpm.
- Operating ambient temperature: 5-60°C
- Maximum combustion air temperature: 60°C
- Noise emission level: 77 dB in 1.5-meter distance
- Casing insulation class: IP43
- Net weight: ~76 kg
- Packing dimensions (L x W x H): ~1220 x 745 x 730 mm

Reference conditions: Ambient temperature 20°C - Gas temperature 15°C - Barometric pressure 1013 mbar - Altitude 0 m (According to BS-EN 676)

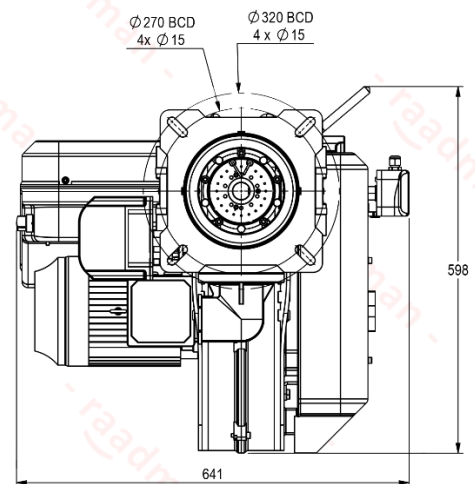
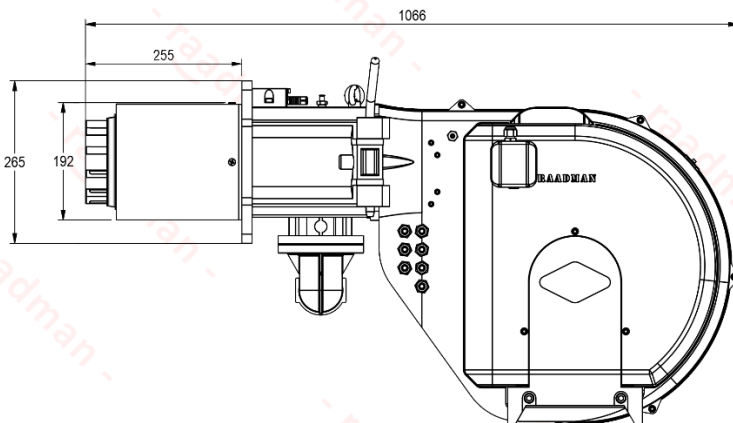
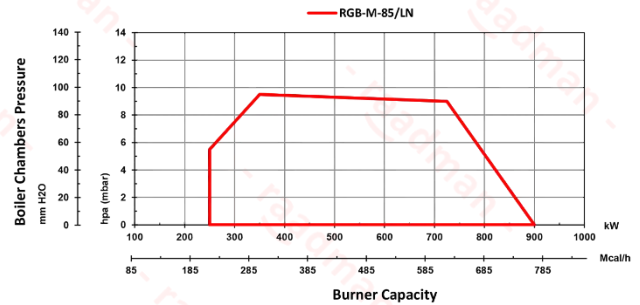

- Suggested boiler flange diameter = 204 mm

Certifications

- Certified in EAEU countries standard No.0378484.
- Certified in Iran national standard ISIRI-7595 (BS-EN 676).



Scan to access:
 Technical proposal
 Technical data
 Technical consultation
 Cad model (only for VIP customers)

