



## RGB-MC-255/LN, Low NOx Mechanical Modular Gas Burner

### Specifications

- Mechanical modulating burner with capacity of 580-2400 kW on gas side (58-240 Nm<sup>3</sup>/h for G20), and turn down ratio of 1:4, and NOx class III.
- Compatible with all types of combustion chambers according to EN-303 or BS-EN 12953 standards.
- Suitable for fire tube, fire box, water tube boilers, etc.
- The burner includes: mechanical components, low NOx burner head designed for emission reduction, flame tube, air fan, control panel, ignition devices, valves and all necessary safety devices in the gaseous fuel line.
- Burner controller: SIEMENS LFL  
The controller includes: main controller (PID controller), load control module, flame detector, actuators.
- The gas train includes: filter, regulator, main and safety valve, pressure gauges, maximum pressure switch, minimum and leak test pressure switch, valve proving system (All according to BS-EN 676).  
The recommended gas trains are offered in two types:
  - Rp2 multi-block low-pressure gas train (inlet pressure of 75-360 mbar).
  - Rp2 separate low-pressure gas train (inlet pressure of 127-360 mbar).
  - If higher pressures are available, lower gas train sizes can be offered for better prices.
- Advantages: optimal design, high modulating ratio, silent operation, the ability to open from the hinge to both sides and ease of installation and maintenance.
- Optional ability: LPG fuel compatibility with LPG nozzle kits.



### More information

- Fan motor: 5.5 kW, 3 Phase, 380-400 Volt, 50 Hz, 2840 rpm.
- Operating ambient temperature: 5-60°C
- Maximum combustion air temperature: 60°C
- Noise emission level: 83 dB in 1.5-meter distance
- Casing insulation class: IP43
- Net weight: ~94 kg
- Packing dimensions (L x W x H): ~1350 x 840 x 730 mm

Reference conditions: Ambient temperature 20°C - Gas temperature 15°C  
- Barometric pressure 1013 mbar - Altitude 0 m (According to BS-EN 676)

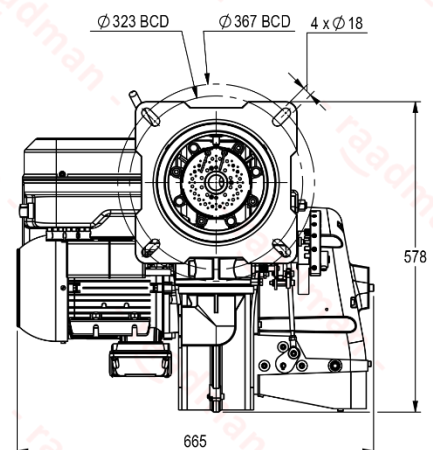
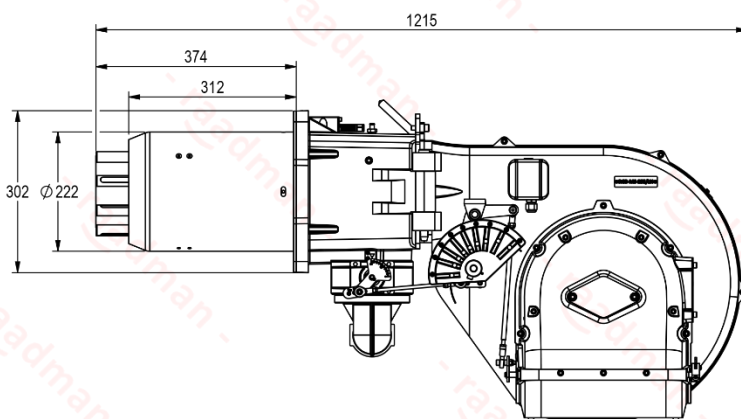
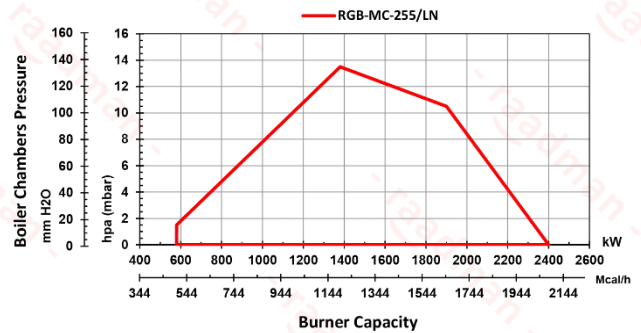

- Suggested boiler flange diameter = 235 mm

### Certifications

- Certified in EAEU countries standard No. 0378484.
- Certified in Iran national standard ISIRI-7595 (BS-EN 676).



Scan to access:  
Technical proposal  
Technical data  
Technical consultation  
Cad model (only for VIP customers)

