



## RGB-MS-505/LN, Low NOx Mechanical Staging Gas Burner

### Specifications

- Mechanical staging burner with capacity of 700-5100 kW on gas side (70-510 Nm<sup>3</sup>/h for G20), and turn down ratio of 1:7, and NOx class III.
- Compatible with all types of combustion chambers according to EN-303 or BS-EN 12953 standards.
- Suitable for fire tube, fire box, water tube boilers, etc.
- The burner includes: mechanical components, low NOx burner head designed for emission reduction, flame cover, air fan, control panel, ignition devices, valves and all necessary safety devices in the gaseous fuel line.
- Burner controller: SIEMENS LFL
- The controller includes: main controller, actuator.
- The gas train includes: filter, regulator, main and safety valve, pressure gauges, maximum pressure switch, minimum pressure switch and leak test pressure switch, valve proving system (All according to BS-EN 676).

The recommended gas trains are offered in two types:

- DN65 separate low-pressure gas train (inlet pressure of 228-360 mbar).
- DN65 separate high-pressure gas train (Inlet pressure of 1-4 bar).
- Advantages: Optimal design, silent operation, the ability to open from the hinge to both sides and ease of installation and maintenance.
- Optional ability: LPG fuel compatibility with LPG nozzle kits.

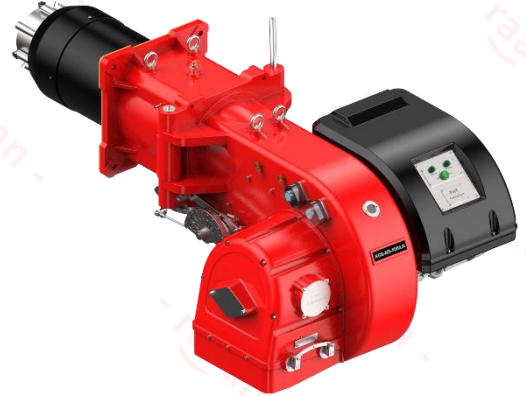

### More information

- Fan motor: 11 kW, 3 Phase, 380-400 Volt, 50 Hz, 2900 rpm.
- Operating ambient temperature: 5-60°C
- Maximum combustion air temperature: 60°C
- Noise emission level: 84 dB in 1.5-meter distance
- Casing insulation class: IP43
- Net weight: ~222 kg
- Packing dimensions (L x W x H): ~1850 x 1140 x 890 mm

Reference conditions: Ambient temperature 20°C - Gas temperature 15°C  
- Barometric pressure 1013 mbar - Altitude 0 m (According to BS-EN 676)

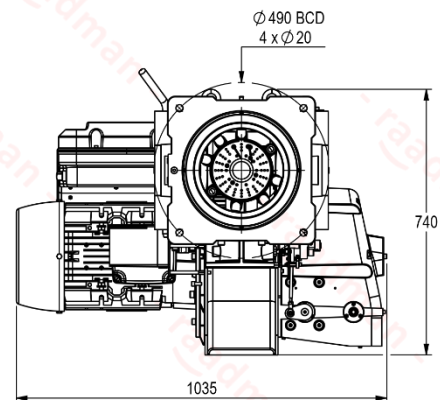
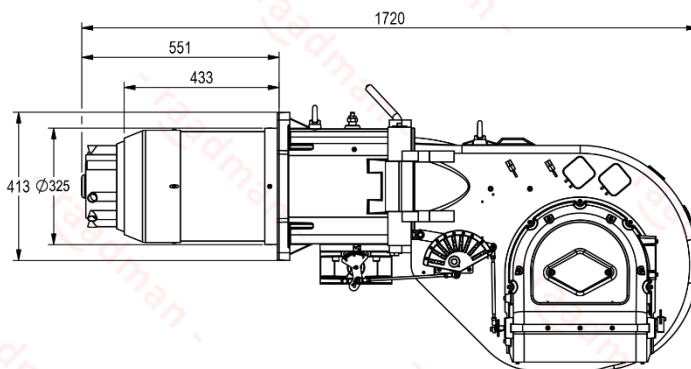
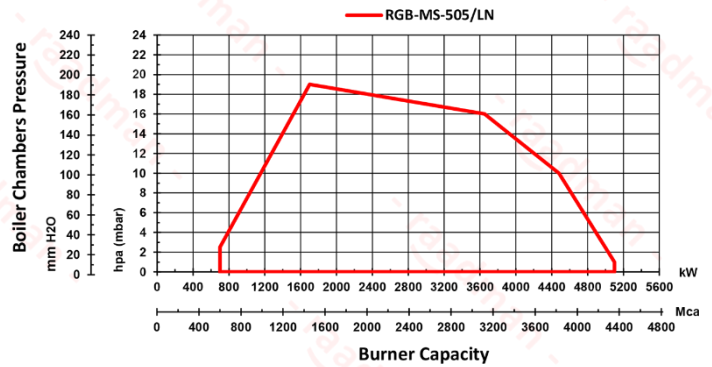

- Suggested boiler flange diameter: ~337 mm

### Certifications

- Certified in EAEU countries standard No. 0378484.
- Certified in Iran national standard ISIRI-7595 (BS-EN 676).



Scan to access:  
Technical proposal  
Technical data  
Technical consultation  
Cad model (only for VIP customers)

