

RLGB-M/M-1550, Electronic Modulating Dual Fuel Burner

Specifications

- Electronic modulating gas power control in the range of 1:8 (1900-15000 kW) with gas capacity of 190-1500 Nm³/h for G20 and II class of NO_x.
 - Electronic modulating light oil power control in range of (3100-15000 kW) with oil capacity of 261-1284 kg/h for light oil and II class of NO_x.
 - Compatible with all types of combustion chambers according to EN-303 or BS-EN 12953 standards.
 - Suitable for fire tube, fire box, water tube boilers, etc.
 - The burner includes: mechanical components, burner head, flame tube, air fan, control panel, external electrical panel for soft starter, ignition devices, air pressure switches, ignition transformers, valves and all necessary safety devices in the gaseous fuel lines.
 - Burner controller: AUTOFLAME MINI MK8/MK8 or SIEMENS LMV5 depends on the policy of the manufacturer based on the market availability or the customer's order.
 - The controller includes: main controller (PID controller), user interface, flame detector, actuators.
- The gas train includes: filter, regulator, main and safety valve, pressure gauges, maximum pressure switch, minimum and leak test pressure switch, pilot regulator, pilot valves, butterfly valve, (All according to BS-EN 676).
- The recommended gas trains are offered in two types:
- DN100 multi block low-pressure gas train (inlet pressure of 250-360 mbar).
 - DN100 multi block high-pressure gas train (inlet pressure of 1-4 bar).
- Light oil delivery system includes: separate motor for oil pump, pump with pressure regulating valve, strainer, double main and safety solenoid valve in feeding line and double main and safety solenoid valve in return line, normally open and normally close solenoid valves for needle, pressure regulator, minimum and maximum oil pressure switch, pressure gauge in feeding line, burner gun, flyback nozzle with needle (All according to BS-EN 267).
 - Advantages: optimal design, high modulating ratio, independent oil motor and air motor, silent operation, valve proving system, communication with external systems via Bus, rail system for ergonomic servicing of the mixing assembly, ease of installation and maintenance.
 - Optional ability: running with FGR (Flue Gas Recirculation) in order to further reduction in NO_x level, variable speed drive, running with O₂ and CO sensors (plus CO₂, NO, NO₂, and SO₂ sensors with AUTOFLAME controller), LPG fuel compatibility with LPG nozzle kits.



More information

- Fan motor: 45 kW, 3 Phase, 380-400 Volt, 50 Hz, 2900 rpm
- Light oil fuel pump motor: 3 kW, 380-400 Volt, 50 Hz, 2940 rpm.
- Operating ambient temperature: 5-60°C
- Maximum combustion air temperature: 60°C
- Noise emission level: 89 dB in 1.5-meter distance
- Casing insulation class: IP43
- Net weight: 1300 kg ±1%
- Packing dimensions (L x W x H): ~2730 x 1980 x 2060 mm

Reference conditions: Ambient temperature 20°C - Gas temperature 15°C - Barometric pressure 1013 mbar - Altitude 0 m (According to BS-EN 676 and BS-EN 267).

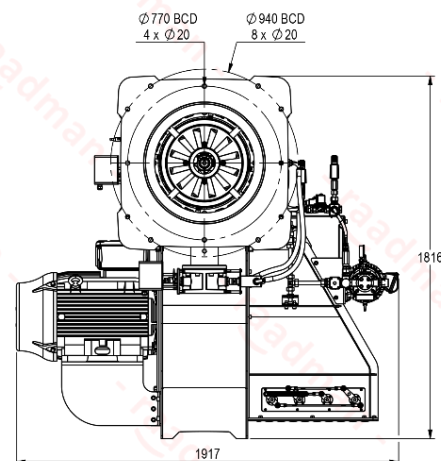
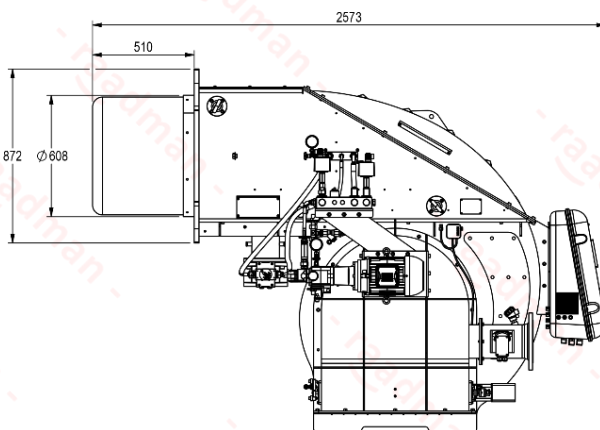
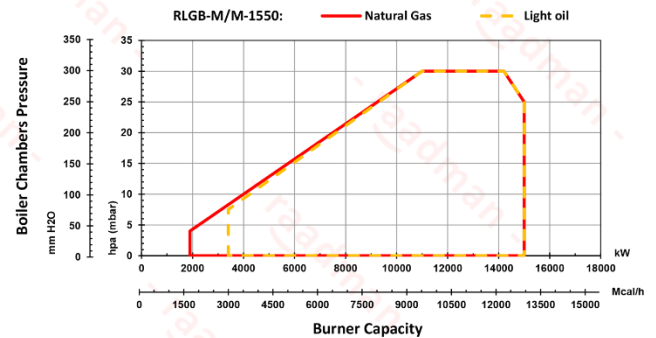

- Suggested boiler flange diameter = 620 mm

Certifications

- Certified in EAEU countries standard No.0378483.
- Certified in EAEU countries standard No. 0378484.
- Certified in Iran national standard ISIRI-7594 (BS-EN 267).
- Certified in Iran national standard ISIRI-7595 (BS-EN 676).



Scan to access:
 Technical proposal
 Technical data
 Technical consultation
 Cad model (only for VIP customers)

