



RLGB-M/M-2250-DB, Electronic Modular Dual Fuel Burner (Dual block configuration)

Specifications

- Electronic modulating burner with capacity of 2750-22000 kW on gas side (275-2200 Nm³/h for G20), and turn down ratio of 1:8, and NOx class II.
- Electronic modulating burner with capacity of 4400-22000 kW on light oil side (371-1855 kg/h), and turn down ratio of 1:5, and NOx class II.
- Compatible with all types of combustion chambers according to EN-303 or BS-EN 12953 standards.
- Suitable for fire tube, fire box, water tube boilers, etc.
- The burner includes: mechanical components, burner head, flame tube, control panel, ignition devices, air pressure switches, Ignition transformers, valves and all necessary safety devices in the gaseous fuel lines.
- Burner controller: AUTOFLAME MINI MK8/MK8 or SIEMENS LMV5 depends on the policy of the manufacturer based on the market availability or the customer's order.
- The controller includes: main controller (PID controller), user interface, flame detector, actuators.
- Burner ventilation system with 25800 m³/h capacity and 65 millibar supply pressure.
- The BVS includes: Fan motor, mechanical components, FGR (optional) and sound proofing material for further reduction in sound level (optional).
- The RMS includes: Inverter, fan, Emergency switch, Compact switch MCCB (optional) and electrical components for power system.
- The gas train includes: filter, regulator, main and safety valve, pressure gauges, maximum pressure switch, minimum and leak test pressure switch, pilot regulator, pilot valves, butterfly valve, (All according to BS-EN 676).
- The recommended gas trains are offered in two types:
 - DN125 Multi-block low-pressure gas train (inlet pressure of 326-500 mbar).
 - DN100 Multi-block high-pressure gas train (inlet pressure of 2-4 bar).
- Light oil delivery system includes: separate motor for oil pump, pump with pressure regulating valve, strainer, double main and safety solenoid valve in feeding line and main solenoid valve in return line, normally open solenoid valves for needle, pressure regulator, minimum and maximum oil pressure switch, pressure gauge in feeding line, burner gun, flyback nozzle with needle (All according to BS-EN 267).
- Advantages: optimal design, high modulating ratio, valve proving system, communication with external systems via Bus, rail system for ergonomic servicing of the mixing assembly, ease of installation and maintenance.
- Optional ability: running with FGR (Flue Gas Recirculation) in order to further reduction in NOx level, variable speed drive, running with O₂ and CO sensors (plus CO₂, NO, NO₂, and SO₂ sensors with AUTOFLAME controller), LPG fuel compatibility with LPG nozzle kits.



More information

- BVS motor: 75 kW, 3 Phase, 380-400 Volt, 50 Hz, 2900 rpm
 - Light oil fuel pump motor: 4 kW, 380-400 Volt, 50 Hz, 2840 rpm.
 - Operating ambient temperature: 5-60°C
 - Maximum combustion air temperature: 60°C
 - Casing insulation class: IP43
 - Combustion block weight: 580 kg ±1%
 - Combustion block Packing dimensions (L x W x H): ~2400 x 1490 x 1480 mm
- Reference conditions: Ambient temperature 20°C - Gas temperature 15°C - Barometric pressure 1013 mbar - Altitude 0 m (According to BS-EN 676 and BS-EN 267)

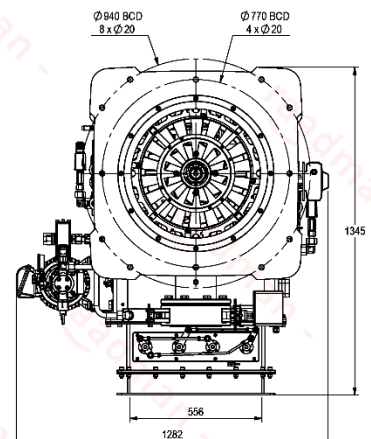
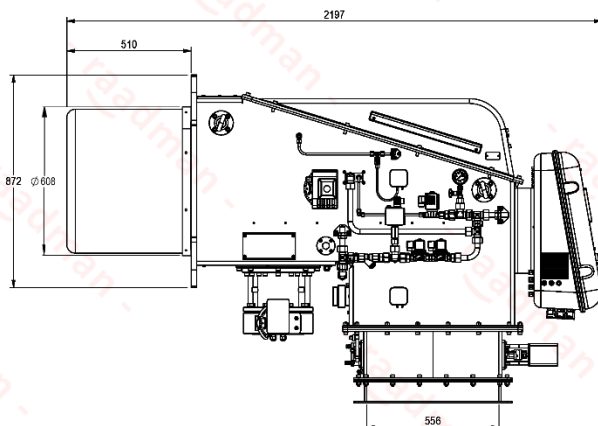
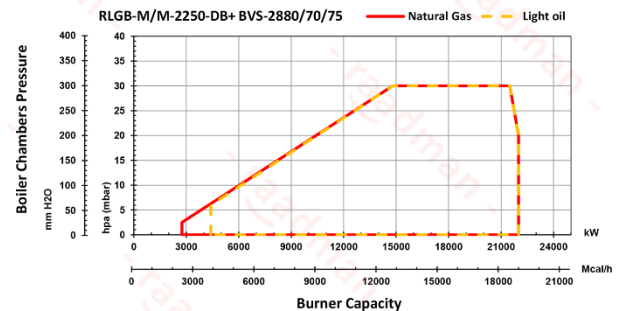

- Suggested boiler flange diameter = 620 mm

Certifications

- Certified in EAEU countries standard No.0378483.
- Certified in EAEU countries standard No. 0378484.
- Certified in Iran national standard ISIRI-7594 (BS-EN 267).
- Certified in Iran national standard ISIRI-7595 (BS-EN 676).



Scan to access:
 Technical proposal
 Technical data
 Technical consultation
 Cad model (only for VIP customers)

