



## RLGB-M/M-605/LN, Low NOx Electronic Modular Dual Fuel Burner

### Specifications

- Electronic modulating burner with capacity of 1000-6100 kW on gas side (100-610 Nm<sup>3</sup>/h for G20), and turn down ratio of 1:6, and NOx class III.
  - Electronic modulating burner with capacity of 1220-6100 kW on light oil side (103-514 kg/h), and turn down ratio of 1:5, and NOx class II.
  - Compatible with all types of combustion chambers according to EN-303 or BS-EN 12953 standards.
  - Suitable for fire tube, fire box, water tube boilers, etc.
  - The burner includes: mechanical components, low NOx burner head designed for emission reduction, flame tube, air fan, light oil delivery system, control panel, ignition devices, valves and all necessary safety devices in the gaseous and light oil fuel lines.
  - Burner controller: AUTOFLAME MINI MK8 (in burner/boiler package), and LAMTEC BT or SIEMENS LMV2/3 depends on the policy of the manufacturer based on the market availability or the customer's order.
  - The controller includes: main controller (PID controller), load control module, dual fuel module, user interface, flame detector, actuators.
  - The gas train includes: filter, regulator, main and safety valve, pressure gauges, maximum pressure switch, minimum and leak test pressure switch (All according to BS-EN 676).
- The recommended gas trains are offered in two types:
- DN80 separate low-pressure gas train (inlet pressure of 193-360 mbar).
  - DN80 separate high-pressure gas train (inlet pressure of 1.5-4 bar).
  - If higher pressures are available, lower gas train sizes can be offered for better prices.
- Light oil delivery system includes: separate motor for oil pump, pump with pressure regulating valve, double main and safety solenoid valve in feeding line and double main and safety solenoid valve in return line, pressure regulator, minimum and maximum oil pressure switch, pressure gauge in feeding line, burner gun, flyback nozzle (All according to BS-EN 267).
  - Advantages: optimal design, high modulating ratio, independent oil motor and air motor, silent operation, valve proving system, communication with external systems via Bus, the ability to open from the hinge to both sides and ease of installation and maintenance.
  - Optional ability: running with FGR (Flue Gas Recirculation) in order to further reduction in NOx level, variable speed drive (VSD), running with O<sub>2</sub> and CO sensors (plus CO<sub>2</sub>, NO, NO<sub>2</sub>, and SO<sub>2</sub> sensors with AUTOFLAME controller), LPG fuel compatibility with LPG nozzle kits.



### More information

- Fan motor: 15 kW, 3 Phase, 380-400 Volt, 50 Hz, 2900 rpm
- Light oil fuel pump motor: 1.5 kW, 380-400 Volt, 50 Hz, 2890 rpm.
- Operating ambient temperature: 5-60°C
- Maximum combustion air temperature: 60°C
- Noise emission level: 85 dB in 1.5-meter distance
- Casing insulation class: IP43
- Net weight: ~280 kg
- Packing dimensions (L x W x H): ~1870 x 1390 x 870 mm

Reference conditions: Ambient temperature 20°C - Gas temperature 15°C  
- Barometric pressure 1013 mbar - Altitude 0 m (According to BS-EN 676 and BS-EN 267).

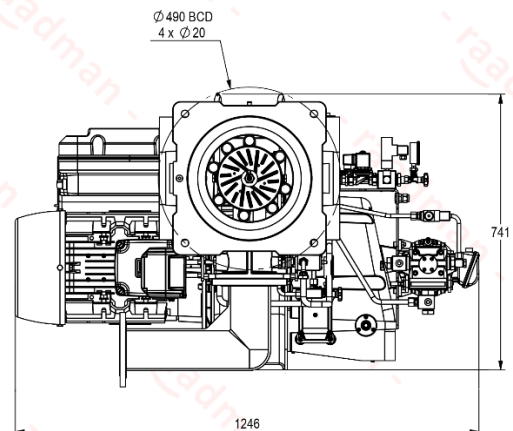
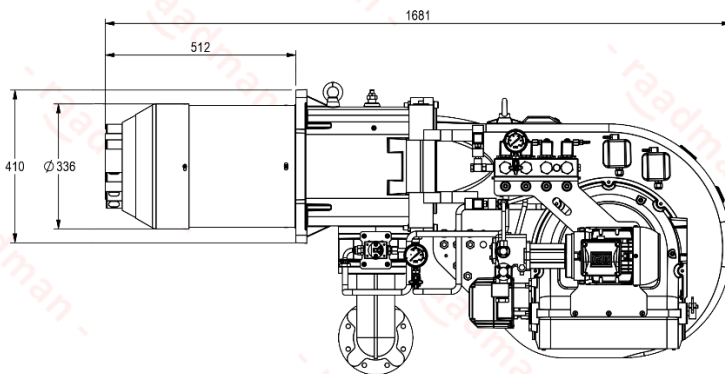
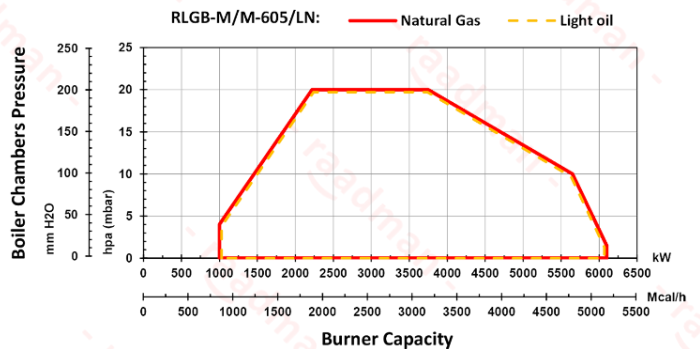

- Suggested boiler flange diameter = 348 mm

### Certifications

- Certified in EAEU countries standard No.0378483.
- Certified in EAEU countries standard No. 0378484.
- Certified in Iran national standard ISIRI-7594 (BS-EN 267).
- Certified in Iran national standard ISIRI-7595 (BS-EN 676).



Scan to access:  
Technical proposal  
Technical data  
Technical consultation  
Cad model (only for VIP customers)

