



A short introduction of PACKMAN modular gas burners

RGB-M Series or RAADMAN Modular gas burners, covering a firing range from 160 to 17000 kW, are designed for a wide range of domestic and industrial applications. All RAADMAN modular burners are equipped with LAMTEC or SIEMENS electronic control system with capability of full air/gas ratio control throughout entire burner operating range. These burners have been tested and evaluated based on Iran national standard ISIRI-7595 (BS-EN 676). According to performed experiments, the values of CO even in low excess air operation is lower than 30 mg/kWh (In some cases, values close to zero have also been reported). The precise design of combustion head results a full gas-air mixture that guarantees high efficiency levels in all various applications. Burner superior design accompanied by high quality electronic devices have also resulted a further improvement in boiler's performance in order to decrease fuel cost and emissions.

RGB-M-385 (650-3800 kW)

RGB-M-385 is an electronic modular gas burner, designed for a wide range of domestic and industrial applications. The values of CO and NOx during burner operation are lower than 30 and 120 mg/kWh, respectively. Therefore, the burner's NOx class of II is reported and approved. The class III of NOx can be obtained using FGR. Compact design, fully electronic modulating operation, silent operation due to injected sound absorbing material already installed on burner and high aspect ratio are important advantage of this burner.

Burner Certificate

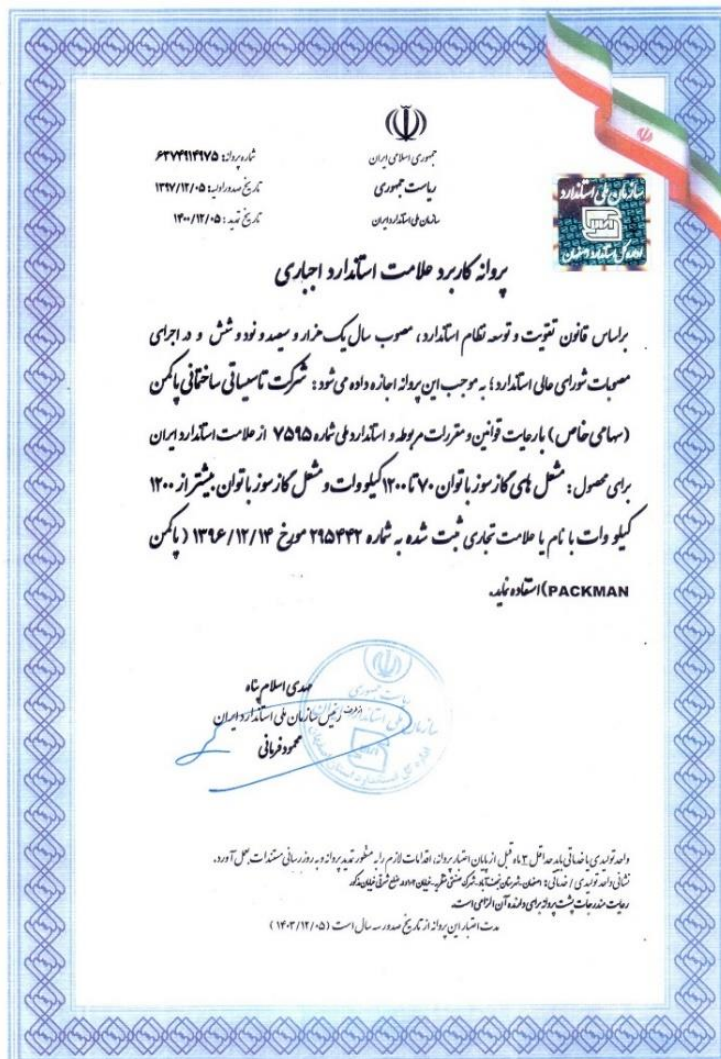

Figure 1 - Burner certification based on the Iran national standard ISIRI-7595, Equal to the BS-EN 676 international standard



General Dimension

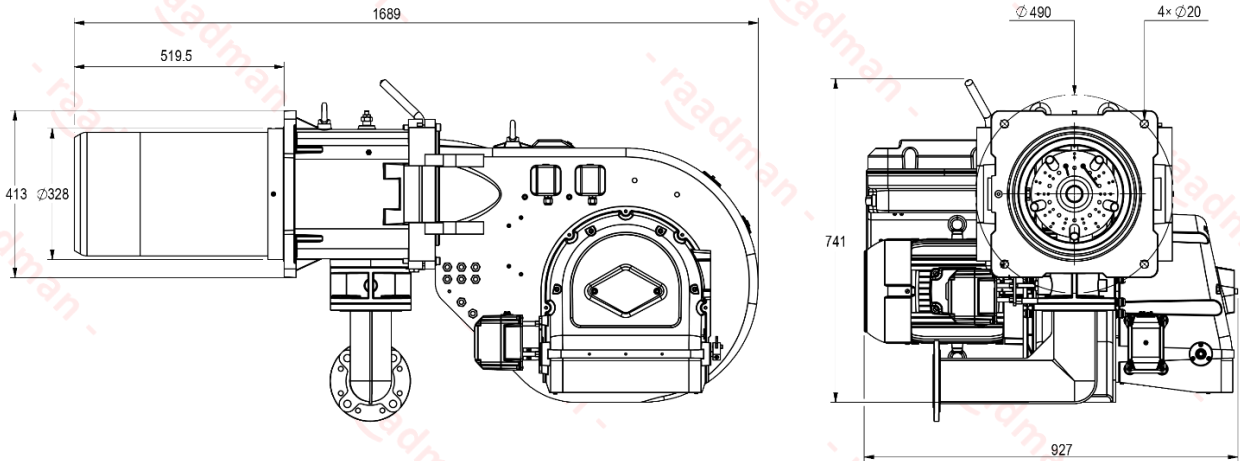

Figure 2 - Burner Dimensions

Notice: Any illegal copy or any kind of partial reversed engineering could be followed by the owner; and this company has the authority to track it by LAW.

Firing Rate

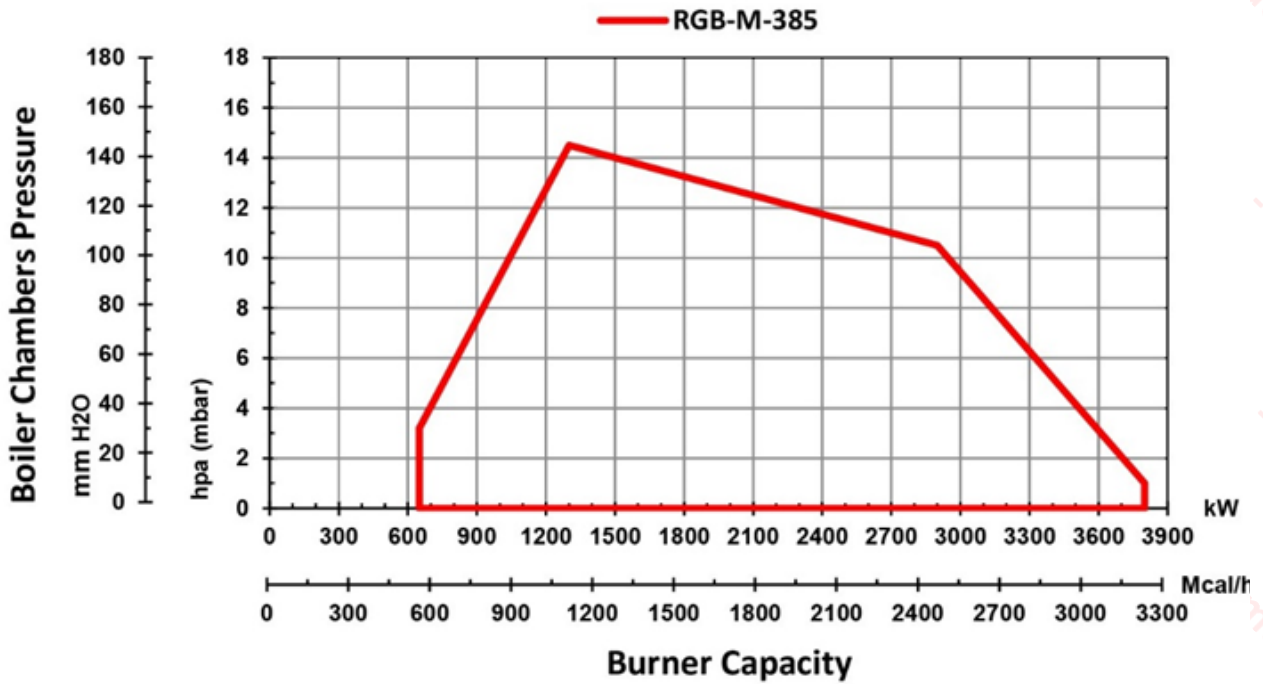

Figure 3 - Burner Firing Diagram



The firing rate diagram has been obtained considering ambient temperature of 20°C and atmospheric pressure of 1013 mbar (Sea level condition) according to the BS-EN 676.



RGB-M-385 Technical and Functional Features

- Highly efficient gas burners for domestic and industrial applications.
- Light weight and optimized geometry.
- Mono-bloc design and fully enclosed aluminum air housing.
- Compatible with all types of combustion chambers according to EN303 standard.
- Simple Installation, adjustment and maintenance.
- Modular operation
- Ability to work based on Air-Fuel control curve.
- Easy access to internal components.
- Engineered for maximize efficiency and fuel cost savings.
- Designed in accordance with 7595 Iran national standard (BS-EN 676)
- Suitable for firetube, firebox and water tube boilers.
- Equipped with high quality and reliable electronic devices.

Table 1- RGB-M-385 Combustion Specification

Item	Description
Fuels	Natural Gas
Gas Capacity **	650-3800 kW
Gas operation	Electronic modular system
Gas Pollution	II class of NOx according to BS-EN 676
Certificates Certificates No.	ISIRI 7595 6374914975
Other abilities	<ul style="list-style-type: none"> -Low excess air operation -Ability to run according to the Air/fuel ratio curve -Ability of Communication with external systems via Bus. -Independent ignition point position for safe burner start -Adjustable pre-purge and post purge time -Absence of joint clearance using linkage less actuators avoiding mechanical hysteresis -Easy commissioning using modular human interface -Parameters indication -History of errors -Mono-bloc configuration -Silent operation (Due to the injected sound absorbing material) -Including valve proving system -Ability of hinged opening of burner housing in both directions -High turn down ratio for avoiding any shut down in low required loads -Economical price using central burner controllers (With improved technology and ease of use, combustion plant is becoming even more economical as: NO additional burner controller is required, Less installation work with less errors, NO additional cost for valve proving, Taking less time for commissioning and service work) - <u>Optional</u> ability to install a variable speed drive for avoiding any impact in startup - <u>Optional</u> ability of running with O2 and CO sensors. - <u>Optional</u> ability of running with FGR in order to further reduction in NOx level

** Reference conditions: Ambient temperature 20°C - Gas temperature 15°C - Barometric pressure 1013 mbar - Altitude 0 m



Table 2 - Recommended Gas Train

Standard gas train: Separated items, DN 65, Up to 500 mbar			
Item	QTY	Specification	Brand*
MVD 2065/5 (Safety valve)	1	Solenoid valve, Single stage gas valve, Fast opening fast closing, Max operating pressure=200 mbar, DN 65	DUNGS
MVDLE 2065/5 (Main valve)	1	Solenoid valve, Double stage gas valve, Slow opening fast closing, Max operating pressure=200 mbar DN 65	DUNGS
FRS 5065	1	Gas regulator, Max operating pressure=500 mbar, DN 65	DUNGS
GF 60065/4	1	Gas filter, Max operating pressure= 6 bar, DN 65	DUNGS
GW 150 A6	2	Gas pressure switch, Range: 5-150 mbar - with plug	DUNGS
MVD 207/5 (Vent valve) **	1	Solenoid valve, Single stage gas valve, Fast opening fast closing, Max operating pressure=360 mbar, Rp ¾	DUNGS
Pressure indicator	1	Range: 0-250 mbar, Rp 1/2	
Pressure indicator	1	Range: 0-600 mbar, Rp 1/2	
Ball valve	2	Rp 1/2	
Collector	1	DN 65 - DN 65	

* Though these brands are common in this type of burner, they would may change based on available components in the market (such as MADAS, SIEMENS, etc.) or according to the policy of Packman Co.

**optional (Depends on customer's offer)



Table 3 - Burner Equipment and Accessories

Power System		
Item	Specification	Brand*
Main motor	7.5 kW, 3 Phase, B5, 380-400 Volt, 50 Hz, 2900 rpm	ABB, LENZE, ELECTROGEN
Bi-metal	LRD14	SCHNEIDER
Contactora	LC1D18, LC1D25	SCHNEIDER
Star-Delta Timing Relay	RE22R1QCMU	SCHNEIDER
Selector switches	XB4 BD21	SCHNEIDER
Burner Management System		
Item	Specification	Brand*
Burner Tronic BT320 (Main controller)	Up to 2 actuators, intermittent operation only, 230 VAC	LAMTEC
Manual interface	UI300 - User Interface with graphic display, in panel installation housing "standard" housing color RAL7016 incl. connecting cable, IP41	LAMTEC
Air actuator	Servomotor 3 N.M protection class IP54, 90° actuating range, 0.1° resolution/step, metal gearbox, cable length 1.5 m	LAMTEC
Gas actuator	Servomotor 1.2 N.M protection class IP54, 90° actuating range, 0.1° resolution/step, metal gearbox, cable length 1.5 m	LAMTEC
load controller	LCM100 - load control unit expansion module incl. LSB interface and 24V power supply, Connecting cable BT300 X31	LAMTEC
Ignition System		
Item	Specification	Brand*
Transformer	Tra.f.a.n union single wire	TRAFO
Other Components		
Item	Specification	Brand*
Air pressure switch (Min switch)	LGW 10 A2, 1-10 mbar	DUNGS
Boiler chamber pressure switch (Max switch)	LGW 50 A2, 2.5-50 mbar	DUNGS

* Though these brands are common in this type of burner, they would may change based on available components in the market or according to the policy of Packman Co.

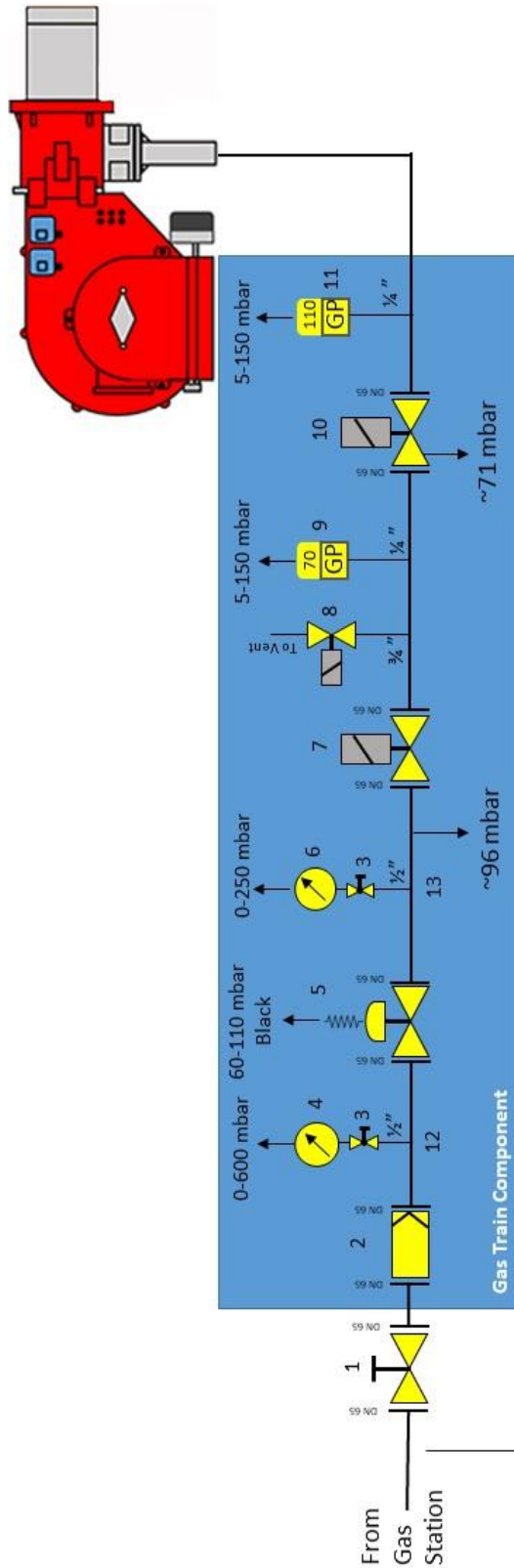

Burner Model: RGB-M-385: Output : 650 – 3800 kW
Gas consumption (G20) : 380 m³/h - General Pipe size : DN 65

Inlet pressure : 130-500 mbar
Pipe general size: DN 65

- 1: Ball valve(Out of scope)
- 2: Gas filter
- 3: Ball valve
- 4: Pressure gauge/(0-600 mbar)
- 5: Pressure regulator
- 6: Pressure gauge/(0-250 mbar)
- 7: Safety gas valve
- 8: Vent solenoid valve (NC)
- 9: Min/leak test gas pressure switch
- 10: Main gas valve
- 11: Max gas pressure switch
- 12: Collector 1
- 13: Collector 2

Figure 4 - Standard gas train, Separated items, DN 65 up to 500 mbar